

9. Governor function ON/OFF (only HELI)

Select governor function ON or OFF.

GOVERNOR MODE	rpmCONTROL OFF	OFF	Select OFF normally.
	rpmCONTROL ON	ON	Select ON when you use the governor function.

※ Governor function works to keep the RPM corresponding to throttle position (throttle curve) against load changes due to pitch operation or voltage changes of the power batteries. Note that higher current of the power batteries is consumed.

When you select the GOVERNOR function ON, set the throttle curve horizontal shown as below.

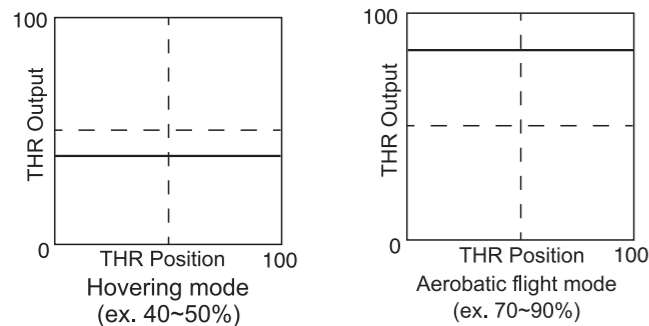

In this setting, you must connect the battery to the ESC only after selecting Throttle Hold Mode and setting Throttle Position 0% in the transmitter, otherwise the rotor turns right away after the connection and may hurt you.

10. Setting of advance timing

Select the advanced angle of the current to the motor or the way to advance the angle.

ADVANCE TIMING	Fixed 8°	Fixed 8°	Advanced angle fixed at 8° General use/For Acro models
	Fixed 16°	Fixed 16°	Advanced angle fixed at 16° When stressing power
	Auto	AUTO	Automatic advance 0~25° Full automatic/General use
	Soft(0-7)	Soft(0-7)	Semi automatic 0~7° General use/Acro models
	Medium(8-15)	Medium(8-15)	Semi automatic 8~15° Helicopters
	Hard(16-25)	Hard(16-25)	Semi automatic 16~25° When stressing power

● How to set

1. Prepare ESC, motor, programming card and batteries.
2. Connect the jumper pin to the terminal of item you would like to set.
3. Connect motor and programming card to the ESC.
4. Connect the ESC to the batteries. Setting is completed after a beep.
5. If the jumper pin is not connected properly, four short alarm beeps sound and setting is stopped. Make sure the jumper pin is connected properly to each item. If the number of the jumper pin is short, setting cannot be done.
6. In case of OPTO ESC, connect 5~8V batteries to the power input connector on the programming card and carry out 4. Procedure.
7. When the setting is done correctly, a beep sounds. If the setting is not done correctly, four beeps sound.

OCA-260 SPECIFICATIONS

Function	Forward-Stop(Brake/Reverse)
Working voltage range	6~25.2V
Load current (Peak)	60A (70A 5 seconds)
BEC output	5.5V, 4A (Peak 5A)
Size	76x40x21mm (Excluding Wirings)
Weight	80g (Excluding Connectors)
Cell number	6-18 Ni-Cd/Ni-MH, 2-6 Li-po
Parameter setting	ESC/Programming card OCP-2 (supplied)
Protective function	Start protection/Low voltage cut-off/No signal cut-off/Overheat protection
PWM Frequency	8~16kHz

OCA-280 SPECIFICATIONS

Function	Forward-Stop(Brake/Reverse)
Working voltage range	6~25.2V
Load current (Peak)	80A (100A 5 seconds)
BEC output	5.5V, 4A (Peak 5A)
Size	76x40x23mm(Excluding Wirings)
Weight	88g (Excluding Connectors)
Cell number	6-18 Ni-Cd/Ni-MH, 2-6 Li-po
Parameter setting	ESC/Programming card OCP-2 (supplied)
Protective function	Start protection/Low voltage cut-off/No signal cut-off/Overheat protection
PWM Frequency	8~16kHz

- ※ Cool Power FET: Latest generation power FET
- ※ Programming card OPC-2: By connecting to the ESC, detailed setting can be done easily.
- ※ Start protection: Stops involuntary starting of the motor.
- ※ Low voltage cut-off: Stops the motor before the voltage reaches the level where control is lost and potential over-discharge damage to the cells occurs.
- ※ No signal cut-off: Switches the ESC OFF when signal from the transmitter is not received.
- ※ Overheat protection: When the temperature rises extraordinary due to overload, restrict output to protect the ESC.
- ※ Battery cell number auto recognition: Function to recognize automatically cell number of the battery to connect.
- ※ BEC output: Power to receiver is supplied from the ESC. SBEC is adopted

● Pay careful attention to the advices with the following headings.

⚠ DANGER

This covers the possibility which might involve death and serious injury.

⚠ WARNINGS

These cover the possibilities which might involve death and serious injury and also may cause damage or injury.

⚠ NOTES

These cover the many other possibilities, generally less obvious source of danger, but which, under certain circumstances, may also cause danger or injury.

Graphic symbols: ⚡ ; Prohibited items ⚠ ; Items never fail to take action

O.S. ENGINES MFG. CO., LTD. 6-15 3-Chome Imagawa Higashiumiyoshi-ku
 URL : <http://www.os-engines.co.jp> Osaka 546-0003, Japan TEL. (06) 6702-0225
 FAX. (06) 6704-2722

© Copyright 2013 by O.S.Engines Mfg. Co., Ltd. All rights reserved. 041401



BRUSHLESS MOTOR ESC
FOR HELICOPTERS/AIRPLANES

OCA-260 / OCA-280



Supplied with OCP-2 (Programming card)

The OCA-260 / OCA-280 are ESC installed with the latest FET for brushless motors. By using supplied Programming card OCP-2, settings of ESC can be programmed quickly and securely to meet model's specific requirements.

● Corresponding motors

For airplanes: Check the specifications of the motor and relationship with the propeller (Dia. and pitch) ,and select propellers with which more than below mentioned current may not flow.

※ **OCA-260:** We recommend O.S. brushless motor OMA-3820 / OMA-3825 / OMA-5010.

※ **OCA-280:** We recommend O.S brushless motor OMA-5010 / OMA-5020 / OMA-5025.

Even with these motors, carefully select propellers with which the load current does not exceed 60A (OCA-260) / 80A (OCA-280).

For helicopters: Select motors with which the load current does not exceed 50A (OCA-260) / 70A (OCA-280)

● Before operating OCA-260 / OCA-280

※ **Misuse or abuse of Li-po batteries is very dangerous. Be sure to follow the instruction manual supplied with the batteries.**

※ **Be sure to install the connectors which match the batteries, securely soldering to the battery connecting wires of the ESC. Never use the ESC with the connectors temporarily connected.**

※ **Applicable batteries: Li-po 2~6 cells (7.4~22.2V), Ni-MH 6~18 cells (7.2~21.6V)**

※ **OCA-260 / OCA-280 are equipped with BEC output as power output for receiver. Do not connect the battery for receiver when connecting the OCA-260 / OCA-280, or both the ESC and batteries may break.**

HOW TO CONNECT THE OCA-260/OCA-280

〔PREPARATION〕

Solder the corresponding battery connector to the battery connection wires of the ESC. Also, use a heat-shrink tube to isolate the connection. Solder the corresponding connectors (female) to the motor connection wires of the ESC. Also, use a heat-shrink tube to isolate the connection.

Connect as shown below.

- Connect to the throttle channel of the receiver.
- ※ **Since the OCA-260/OCA-280 is integrated with BEC, never connect separate battery to the receiver.**
- Connect to the OCP-2 when the settings are made with the OCP-2.

● Connect to the brushless motor.

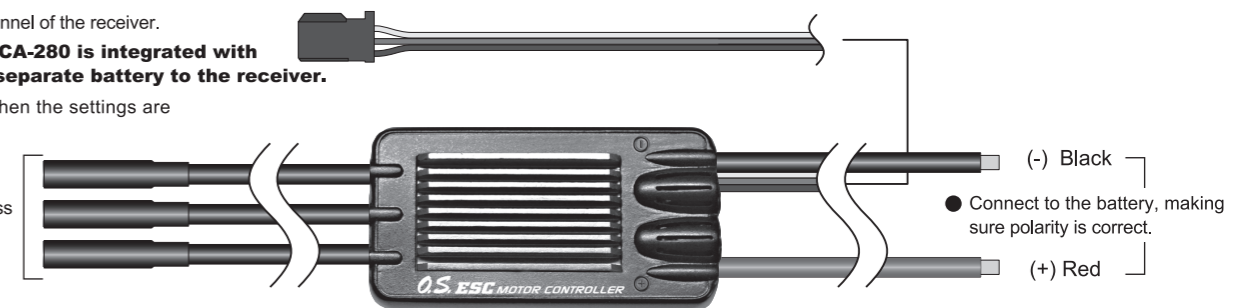

OCA-280

INSTRUCTION MANUAL

IMPORTANT: It is of vital importance, before attempting to operate your OCA-260/OCA-280 to read through this instruction manual.

■ Notes on installation

⚠ WARNINGS

⚠ **Never use the OCA-260/OCA-280 beyond the working conditions listed in the specifications listing.**

⚠ **Do not mistake the polarity of the batteries.**

※ Reverse connection may cause fire and ESC will be damaged or be burnt instantly.

⚠ **Never short out any place of the ESC, batteries, motor, receiver and connectors.**

※ Short circuit may cause fire and ESC will be damaged or be burnt instantly.

※ Be sure to install the ESC so that the soldering connection of the input/output wires may not touch conductive part.

⚠ **Be sure to install the receiver and receiver antenna away from the place where high current flows such as ESC, motor wires, battery wires, power batteries.**

※ Malfunction of the receiver due to noise will cause to lose model control which is very dangerous.

⚠ **Be sure to insert connectors all the way securely.**

※ Disconnection due to vibration may cause to lose model control which is very dangerous.

⚠ **Be sure to install the ESC so that oil, grease and water may not come in contact with the ESC.**

⚠ **Be sure to install the ESC at the place where there is plenty of air flow for cooling.**

⚠ **Do not wrap the ESC with aluminum foil, etc.**

※ Wrapping may spoil cooling effect and the ESC may not develop its original performance.

⚠ **Be sure to install the motor securely and fix all the wires.**

⚠ NOTE

⚠ **Do not disassemble. Do not open the ESC case.**

※ Opening of the case may cause damage inside components and render it irreparable.

■ Notes on operation

⚠ WARNINGS

⚠ **Never touch or allow any part of the body to come into contact with any rotating part while operating.**

※ Sudden rotating may cause serious injury.

※ Be careful with some receivers the motor may rotate for a moment when the power puts on.

⚠ **Do not fly when rainy.**

※ Entry of water drops into the ESC may cause malfunction and out of model control which is very dangerous. Also, it will cause failure. If malfunction is detected due to entry of water drops, send the ESC to the manufacturer or its distributor in each country for inspection and repair.

⚠ **Be sure to follow the procedures mentioned below as to ON and OFF of the power switch.**

● **ON:** Hold the throttle stick at stop position. Switch on **the transmitter then receiver** power.

● **OFF:** Hold the throttle stick at stop position. Switch off **the receiver then transmitter** power.

※ With reverse procedure propeller may rotate suddenly, which is very dangerous.

⚠ **Be sure to remove the batteries when not in use.**

※ Accidental switching on may cause sudden rotating of propeller or cause fire, which is very dangerous.

⚠ **Be sure to check the ESC and all the movements of model controls before attempting flight.**

※ Incorrect settings or using of unsuitable model may cause to lose model control which is very dangerous.

⚠ NOTE

⚠ **Do not touch the motor nor ESC right after flight.**

※ Touching them may cause burn.

INSTALLATION OF THE ESC

Install the ESC in the model using Velcro tape or double faced tape so that it may not be affected by vibration or shock. Make sure both the ESC and motor receive plenty of air flow for cooling via cooling hole. Insufficient cooling by air may damage the ESC and motor.

Notes on Operation

- ※ When using the BEC, it is suggested to set the BEC current less than 4A with the OCA-260 / OCA-280.
- ※ It is suggested to use maximum current of the motor less than one minute.
- ※ Since the overheat protection function is integrated with the ESC, motor stops running when the FET temperature rises to the limit.
- ※ When the signal from the transmitter is not received for approx. 3 seconds, motor stops. When the signal from the receiver is input, motor starts running with the throttle at stop position or brake position.
- ※ Do not connect to the batteries with wrong polarity, or the ESC will be destroyed immediately.
- ※ If the ESC is connected to the batteries with the throttle high, short beeps start sounding after approx. 5 seconds. In this case, pull down the throttle to the stop position or brake position, or disconnect the batteries from the ESC.

⚠ WARNINGS

- ❗ Be sure to connect the ESC to batteries just before the flight and disconnect it right after landing.
 - ❗ When the ESC is connected to batteries, handle the model with utmost attention.
 - ❗ Rotating propeller is very dangerous. Always make sure you are safe and away from the rotating propeller.
 - ❗ Model equipped with a strong motor is very dangerous.
 - ❗ A strong motor system is very dangerous.
 - ❗ Large current may heat leads and batteries. Be sure to connect leads with utmost care. Poor connection may cause fire and burn.
- ※ Fly the model only at permitted airfield. Never fly it over nor near the onlookers. While this ESC is equipped with a safety alarm program, as owner you alone are responsible for safety operation of your motor, ESC and batteries, so act with discretion and care at all times.

SETTINGS USING PROGRAMMING CARD OCP-2

By using a supplied ESC Programming Card OCP-2, parameters of the ESC can be set quickly and securely to meet model's specific requirements. The OCP-2 cannot be used with other ESCs than the OCA-260/OCA-280. The programmer OCP-1 cannot be used with the OCA-260/OCA-280.



● Connection of the programming card

Connect the OCP-2, power battery and motor to OCA-260/OCA-280 as explained before.

● Setting items

Items can be set with the OCP-2 are listed below.

1. Battery Type
2. Cut off cell Voltage
3. Cut off Type
4. Start Power
5. Acceleration
6. PWM Frequency
7. Brake Type
8. Rotation
9. Governor Mode
10. Advance Timing

NORMAL SETTING

Switch the transmitter on and make sure ATV/AFR shows +/-100% (in case of computer radio). In case of a Futaba transmitter, set the throttle channel "Reverse". When connecting to the batteries, be sure to pull down the throttle or place the throttle at brake position. You may hear "start sound" and the motor starts running.

SETTING OF THROTTLE POSITIONS

- Do not install a propeller on the motor yet.
- Switch the transmitter "ON". In case of a Futaba transmitter, set the throttle channel "Reverse".
- Pull down the throttle fully and connect the ESC to the batteries.
- "Start sound" mentioned below will sound. If not, adjust the ATV/AFR value.
- Lowest throttle position is set with battery cell number beeps plus a beep in case of brake ON or two beeps in case of brake OFF.
- Full throttle position is fixed. Power reduction can be adjusted by the value of ATV/AFR.
- Disconnect batteries from the ESC.

DEFAULT

Battery Type	: Li-po
Cut off cell Voltage	: 3.2V
Cut off Type	: Reduce power
Start Power	: Soft
Acceleration	: Normal
PWM Frequency	: 16KHz
Brake Type	: Off
Rotation	: Normal
Governor Mode	: Off
Advance Timing	: Auto

● Explanation of the terminals

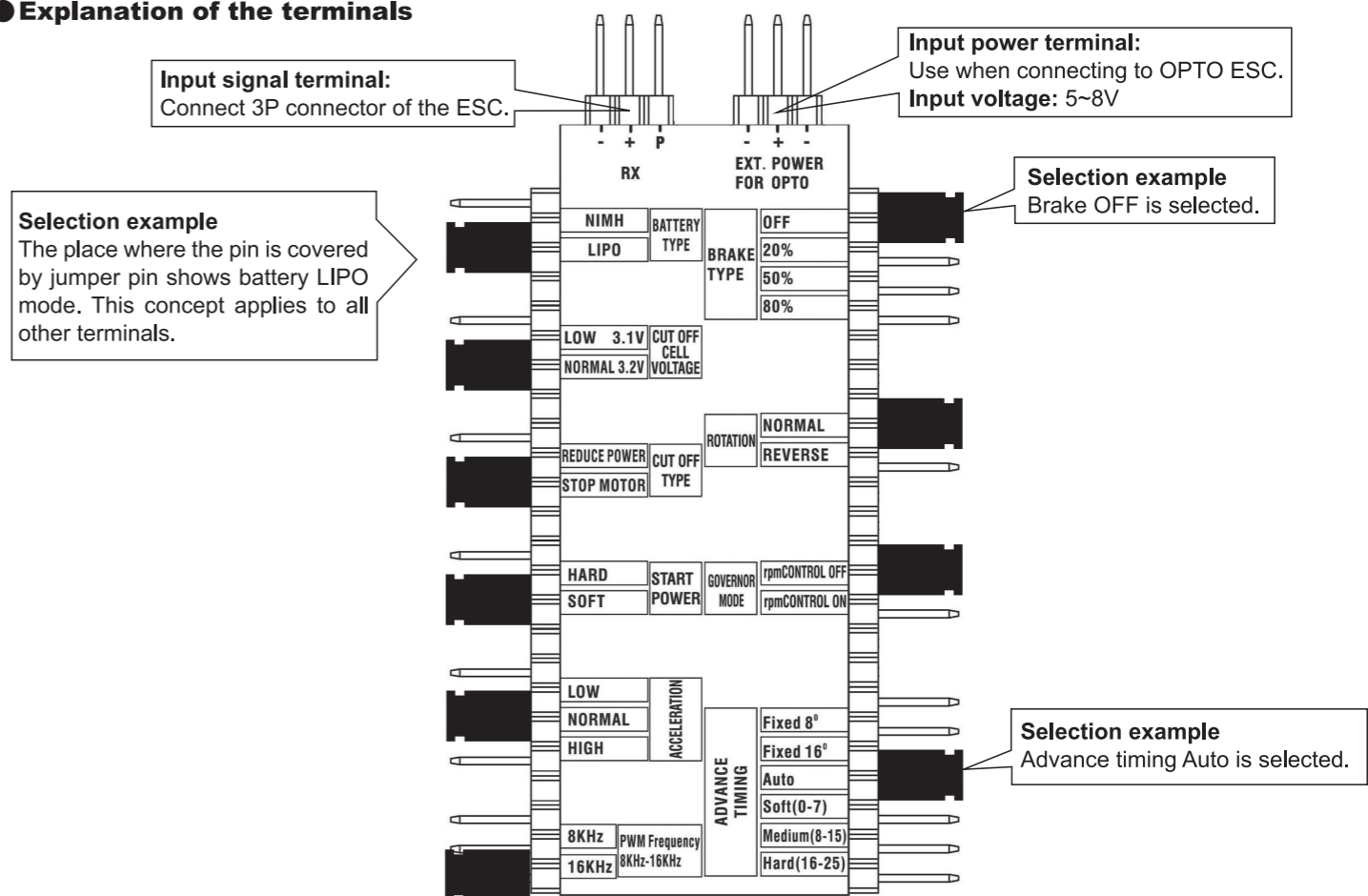

1. Selection of battery type

Select power battery type to use.

NIMH	BATTERY TYPE	NIMH (Nickel-metal-hydrde battery) (Cut of voltage is fixed at 50% of the initial voltage.) LIPO (Lithium polymer battery)
LIPO		

2. Setting of cut off voltage

Set the cut off voltage of Li-Po battery.

LOW 3.1V	CUT OFF CELL VOLTAGE	LOW 3.1V
NORMAL 3.2V		NORMAL 3.2V

3. Selection of cut off type

Select the motor behavior when the battery voltage drops.

REDUCE POWER	CUT OFF TYPE	REDUCE POWER Reduce the motor power to the half.
STOP MOTOR		STOP MOTOR Stop the motor output.

4. Setting of start power

Set the power (torque) level of the motor starting up.

HARD	START POWER	HARD For general airplanes
SOFT		SOFT For starting by SW with gliders and models using gears such as helicopters.

5. Setting of acceleration

Set the motor response speed to the throttle work.

LOW	ACCELERATION	LOW When a larger propeller is used.
NORMAL		NORMAL Normal use
HIGH		HIGH When quicker throttle response is required. Heat of the ESC and current consumption increase.

6. Setting of PWM frequency

Set the switching frequency of the current to the motor.

8KHz	PWM Frequency	8KHz When the motor tends to lose steps.
16KHz		16KHz Select this normally.

7. Setting of brake type

Set the strength of brake. When slowing down with brake, the motor regenerates.

BRAKE TYPE	OFF	OFF Set OFF normally.
	20%	20% Brake strength is weak/for general purpose
	50%	50% Brake strength is normal/for glider
	80%	80% Brake strength is strong/for glider

8. Selection of motor rotating direction

Select motor rotating direction.

ROTATION	NORMAL	NORMAL Normal rotating direction
	REVERSE	REVERSE Reverse rotating direction