

It is of vital importance, before attempting to operate your engine, to read the general 'SAFETY INSTRUCTIONS AND WARNINGS' in the following section and to strictly adhere to the advice contained therein.

- Also, please study the entire contents of this instruction manual, so as to familiarize yourself with the controls and other features of the engine.

SAFETY INSTRUCTIONS AND WARNINGS ABOUT YOUR O.S. ENGINE

Remember that your engine is not a "toy", but a highly efficient internal-combustion machine whose power is capable of harming you, or others, if it is misused or abused. As owner, you, alone, are responsible for the safe operation of your engine, so act with discretion and care at all times. If at some future date, your O.S. engine is acquired by another person, we would respectfully request that these instructions are also passed on to its new owner.

The advice which follows is grouped under two headings according to the degree of damage or danger which might arise through misuse or neglect.

WARNINGS

These cover events which might involve serious (in extreme circumstances, even fatal) injury.

NOTES

These cover the many other possibilities, generally less obvious sources of danger, but which, under certain circumstances, may also cause damage or injury.

WARNINGS

Never touch, or allow any object to come into contact with, the rotating propeller and do not crouch over the engine when it is running.

Model engine fuel is poisonous. Do not allow it to come into contact with the eyes or mouth. Always store it in a clearly marked container and out of the reach of children.

Model engine fuel is also highly flammable. Keep it away from open flame, excessive heat, sources of sparks, or anything else which might ignite it. Do not smoke or allow anyone else to smoke, near to it.

Model engines generate considerable heat. Do not touch any part of your engine until it has cooled. Contact with the muffler (silencer), cylinder head or exhaust header pipe, in particular, may result in a serious burn.

Never operate your engine in an enclosed space. Model engines, like automobile engines, exhaust deadly carbon-monoxide. Run your engine only in an open area.

NOTES

- This engine was designed for model boats. Do not attempt to use it for any other purpose.
- Mount the engine in your model securely, following the manufacturers' recommendations, using appropriate screws and locknuts.

NOTES ON OPERATION

NOTE

- This engine rotates clockwise. Do not force it to turn counter-clockwise.
- We do not recommend running your boat on the sea, or in any other saltwater environment. Under such conditions, it is difficult to prevent the engine from becoming corroded and, eventually, inoperative.

FLEXIBLE DRIVE SHAFT

If, due to accidental damage or wear, the flexible drive shaft should require replacement, proceed as follows. (Note: a wise precaution is to have a spare flexible shaft on hand for such emergencies.)

- With aid of the correct sized screwdrivers and hexagon keys, separate the complete lower end (outboard unit assembly) from the power-head and remove all parts necessary to give access to the flexible drive shaft. This has squared ends that fit into the PTO shaft at the power-head and the propeller shaft at the bottom end. Note that the propeller shaft bearing has a left-hand thread.
- Remove the flexible drive shaft and its sleeve and if any debris is found in the sleeve, wash it out with fuel or alcohol before greasing the full length of the new shaft and reinserting it into the sleeve.
- Make sure that the ends of the new shaft fit properly into the PTO shaft and propeller shaft and that the new flexible shaft rotates smoothly. Then replace the curved side plate, cavitation plate, etc. and rejoin the power-head with the lower assembly. Gently turn the flywheel to check that the propeller rotates smoothly before tightening assembly screws.

NOTE

As delivered, the engine has the carburetor lightly fit into its intake. Secure it changing its angle according to the hull.

ABOUT THE ENGINE

The O.S. MAX-21XM Ver.II is a high-performance air-cooled outboard marine engine for small and medium-size radio-controlled outboard boats. It is of sturdy construction and designed for easy maintenance. It is not necessary to readjust the linkage when the installation angle to the hull is changed. A tilt mount is supplied as standard. Also, a carbon-fibre propeller is included.

Standard accessories

- Glow Plug No.8 1piece

- Install an effective silencer (muffler). Frequent close exposure to a noisy exhaust (especially in the case of the most powerful high-speed engines) may eventually impair your hearing and such noise is also likely to cause annoyance to others over a wide area.

- For their safety, keep all onlookers (especially small children) well back (at least 20 feet or 6 meters) when preparing your model for running.

- Take care that the glowplug clip or battery leads do not come into contact with the propeller or any other rotating parts. Also check that the linkage to the throttle arm is secure.

- If your engine does not have a built-in recoil starter, use an electric starter. The wearing of safety glasses is also strongly recommended.

- When handling the boat immediately prior to launching, be especially cautious. Keep the propeller and other rotating parts away from you.

- Before starting the engine, always check the tightness of all the screws and nuts especially those of joint and movable parts such as throttle arm. Missing retightening the loose screws and nuts often causes the parts breakage that is capable of harming you.

- Adjust the throttle linkage so that the engine stops when the throttle stick and trim lever on the transmitter are fully retarded. Alternatively, the engine may be stopped by cutting off the fuel supply. Never try to stop the engine physically.

- Warning! Immediately after a glowplug-ignition engine has been run and is still warm, conditions sometimes exist whereby it is just possible for the engine to abruptly restart if it is rotated over compression WITHOUT the glowplug battery being reconnected.

INSTALLING THE GLOWPLUG

Install washer on glowplug and insert carefully into cylinder-head, making sure that it is not cross-threaded before tightening firmly.

TOOLS, ACCESSORIES, etc.

The following items are necessary for operating the engine.

Items necessary for starting

FUEL

Use only top quality commercial model two-stroke engine fuel. For consistent performance and long engine life, it is essential to use fuel containing AT LEAST 18%(volumetric ratio)best-quality lubricant. This engine is designed to run on both low and high nitromethane content fuels, i.e. from mild mixtures containing a few percent of nitromethane, up to high-speed racing fuels containing 30%, or more, of nitromethane. Generally, power output is increased up to a certain point as the nitromethane content of the fuel is increased. As a starting point, we recommend a fuel containing 10% nitromethane, changing to a fuel containing more nitro if necessary. When the nitro content of the fuel is increased or the brand of fuel is changed, it is advisable to run the engine with a richer needle-valve setting, initially, so that the optimum setting for the new fuel may be rechecked as described in the RUNNING-IN paragraph.

PROPELLER

The MAX-21XM supplied special carbon-fibre propeller has a diameter of 42mm and a P/D ratio of 1.2. If any other propeller is substituted, make sure that it is properly balanced.

GLOWPLUG IGNITER

Commercially available handy glowplug heater in which the glowplug battery and battery leads are integrated.

STARTER BELT

Necessary for starting the engine. It is suggested to keep a starter rope as a reserve.

ELECTRIC STARTER AND STARTER BATTERY

Use a 12-volt electric starter with suitable battery for starting the engine.

SUPER FILTER (L) (optional extra)

Install a filter to the outlet tube of your refuelling container to prevent entry of foreign matter into the fuel tank.

O.S. SPEED Silicone Fuel Line (optional extra)

The connection between the fuel tank and the engine. ID. 2.5mm Length 1000mm

TOOLS

- O.S. SPEED DRIVER TOOLS (optional extra)
- O.S. SPEED PLUG WRENCH (optional extra)

ENGINE PARTS NAME

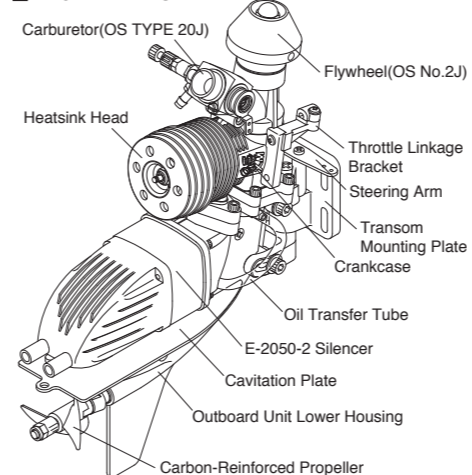

INSTALLATION OF THE CARBURETOR

As delivered, this engine has its carburetor lightly installed into the intake boss. Secure it as follows.

- Loosen the retainer screw and rotate the carburetor to its proper position in the intake boss.
- The carburetor is aligned vertically and sealed against air leaks by a heatproof rubber gasket between the carburetor body and the rim of the intake boss. Therefore, press the carburetor firmly down into the intake boss while rotating the retainer screw. Turn the screw gently until it stops, then tighten a further 90°. Do not tighten any farther as the carburetor body will be damaged.

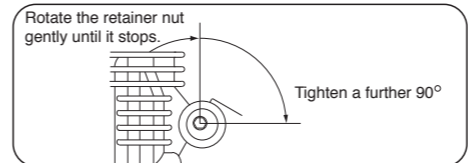

INSTALLATION OF THE ENGINE

The face of the mounting plate is precision machined flat. Make sure that the hull's transom is also flat. The adjacent hull structures should be as rigid as possible so that the engine will be able to develop its full performance. Use 4mm steel screws, such as Allen type socket head cap screws, with locknuts or lockwashers for bolting the engine to the hull. For extra security, apply LOCTITE to the screw threads to prevent nuts vibrating loose.

LINKAGES

Steering Linkage

Use a high-torque servo, preferably with dual pushrods as shown below. (A single pushrod will bend easily which results in poor steering accuracy.)

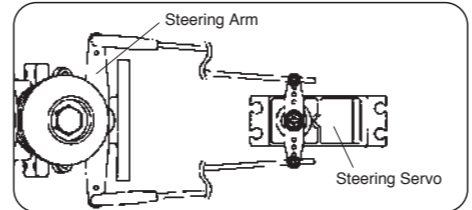

Throttle Linkage

Use flexible 'Bowden' type cable having a 3mm OD outer sleeve. Secure one end of the sleeve to the engine, by means of the throttle linkage bracket supplied, and the other end to any appropriate part of the hull structure immediately surrounding the throttle servo. (See sketch) If the two ends are not secured in this way, steering the boat will upset throttle control. Make sure that no strain is imposed on the throttle cable when steering fully left or right. Adjust the throttle linkage so that the throttle can be fully closed to stop the engine prior to lifting the boat from the water. (If necessary, consult your R/C system handbook for setting up linkage in relation to transmitter stick movement.)

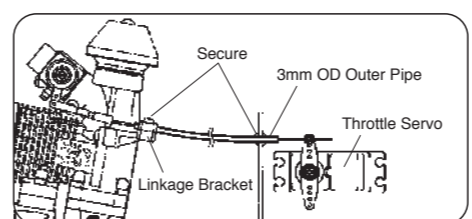

CARBURETOR CONTROLS (20J)

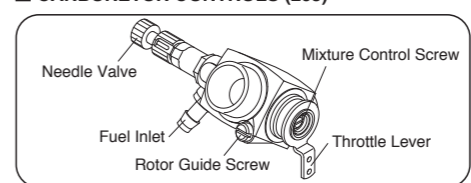

Two adjustable controls are provided on this carburetor.

The Needle-Valve:

For adjusting the mixture strength when the throttle is fully open.

The Mixture Control Screw:

For adjusting the mixture strength at part-throttle and idle speed, to obtain steady idling and smooth acceleration to mid speeds.

REALIGNMENT OF MIXTURE CONTROL VALVE

In the course of making carburetor adjustments, it is just possible that the Mixture Control Valve may be inadvertently screwed in or out too far and thereby moved beyond its effective adjustment range. Its basic setting can be reestablished as follows: The basic (factory) setting is as shown in the main sketch, i.e. with the shoulder portion 'A' exactly at a tangent to the throttle rotor hole. To return the Mixture Control Valve to its original position, first screw in the Mixture Control Valve, while looking into the rotor hole. Then gradually unscrew the Mixture Control Valve until 'A' is precisely tangential to the rotor hole (i.e. so that 'A' and 'B' are superimposed) as in the main sketch.

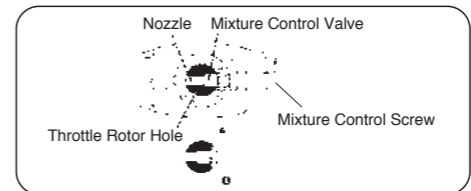

STARTING THE ENGINE & RUNNING-IN ('Breaking-in')

Note

The right rotation of this engine is that the flywheel turns right (clockwise). Do not mistake polarity of the starter or the flexible wire will be damaged due to excessive load.

RUNNING-IN ('Breaking-in')

Running-in is a procedure for an engine to come close to actual running conditions (fuel, r.p.m., engine temperature, etc.).

Excessively rich running and prolonged low speed running should be avoided. Prolonged low speed running and low temperature running may result in the oil in the fuel becoming gelled and the piston/liner becoming stuck together.

PRESSURIZED FUEL SYSTEM

- The somewhat violent changes of hull attitude that occur in running, combined with the fact that, in boats the fuel tank is often located some distance from the carburetor, means that fuel 'head' at the carburetor can vary and upset running. Therefore, it is recommended that a muffler pressurized fuel feed system be used.

- Set the needle-valve. Turn the needle clockwise slowly, without forcing, until it stops. Then, reopen the needle-valve 2-1/2turns counter-clockwise.

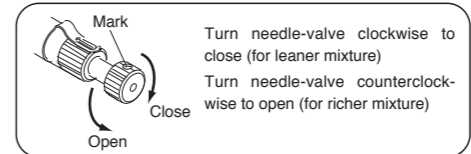

- Open the throttle very slightly:

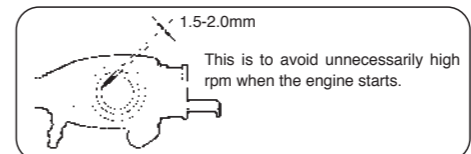

- Heat the glowplug by connecting the battery leads.

- Make sure that the direction of rotation of the electric starter is correct, namely, clockwise. If necessary, reverse leads on battery to provide clockwise rotation.

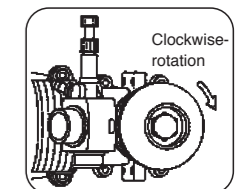

- Bring the starter into contact with the flywheel and depress the starter switch for one or two seconds. Repeat if necessary. When the engine fires, withdraw the starter immediately.

Warning:

Do not apply the starter to a flooded engine and never place your finger over the carburetor intake when using the starter. This may cause a hydraulic lock and bend the connecting-rod.

- Adjusting the needle-valve: adjust the needle-valve to its optimum setting only while actually running your boat on the water.

- To stop the engine, fully close the throttle to cut off air supply.

RUNNING-IN ('Breaking-in')

For long life and high-performance, every engine needs to be properly 'run-in' or 'broken-in'. There are several running-in methods, but the following is suitable for use with the MAX-21XM Ver.II.

- Turn the Needle-Valve clockwise slowly and gently until it stops. This is the fully closed position. Do not use force to turn the Needle-Valve beyond this point. Now reopen the Needle two-and-one-half turns. (The set-screw on the Needle-Valve knob may be used as a reference mark.)
- Set the throttle at the starting position, (i.e. very slightly opened from idling position) and start the engine.

WARNING!

It is vitally important to set the throttle at the correct starting position before starting the engine. If the engine is allowed to run under 'no-load' conditions, it will speed up to extremely high rpm — even at part-throttle settings — which may result in serious damage.

Be careful not to put excessive load on the steering servo when starting the engine with an electric starter.

It is advisable to set the steering fully left before applying an electric starter.

- It is necessary to warm up the engine by running it at near the idling setting for a while after starting, as with the engine of a full size boat. High r.p.m. operation without warming up will shorten engine life or damage it.
- Leaving the Needle-Valve set at the starting setting of 2-1/2 turns open, run the boat several times with the throttle fully open until at least three full tanks of fuel have been consumed. (It should be noted that, at this stage, it may not be possible for the engine to idle reliably because of the over-rich setting of the Needle-Valve.)
- This completes the initial running-in stage. For the remaining period of running-in, refer to the adjustment procedures detailed later. The boat will need to be run for about 10 tanks of fuel to complete the running-in period.

Note!

If as a result of your boat being capsized, the engine takes in water, remove the glowplug, invert the engine and eject water by carefully turning the flywheel, first by hand and then with the electric starter.

Make every effort to ensure that no water remains in the engine before attempting to restart it, or it may be damaged by an hydraulic lock.

To ensure that any traces of water (which may also cause internal rusting if not dealt with) are flushed out, use an appropriate water-displacing spray lubricant.

ADJUSTMENT

WARNING :

Running the engine with the boat out of the water, without load and without cooling water, will seriously damage it, due to overheating. Therefore, always lower the boat into the water immediately after the engine has been started, so as to prevent over-speeding and to allow cooling water to be forced up to the cylinder-head. Having carried out the initial running-in ("breaking-in") procedure as described before, complete the running-in as follows:

1. Open the throttle slightly from the idling position and start the engine, following the procedure described previously.

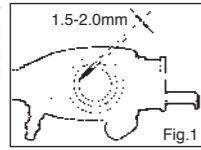

2. Lower the boat into the water, gradually open the throttle and run the boat straight ahead for 20 to 30 metres at full throttle. Now return the model and close the needle-valve 20 to 30°. Repeat the run, taking note of the improvement in speed.

3. Continue with further runs, gradually closing the needle-valve (20 to 30° at a time) until no further increase in speed is obtained.

4. If the needle-valve is closed beyond the optimum setting, the model will slow down, accompanied by visibly diminished exhaust smoke. In this case, immediately throttle down and return the model to shore. Re-open the needle-valve approximately one-half turn and repeat the runs until the optimum needle setting is found.

5. Aim to have the model achieving its highest performance after the engine has consumed about one quart of fuel. Having found the optimum needle-valve setting, make a note of the number of turns necessary to re-establish this from the closed position.

6. With the engine run-in and the optimum needle-valve setting determined, the mixture control valve should be checked as follows:

7. Launch the boat and gradually open the throttle to its fullest extent. If at this point, the engine puffs out a good deal of smoke and does not accelerate smoothly and rapidly, it is a sign that the idling mixture is too rich.

Therefore, turn the mixture control screw clockwise 45 to 60°. Repeat the run and recheck the result.

8. If, on the other hand, the idling mixture is too lean, the engine is likely to speed up momentarily, then cut out abruptly when the throttle is re-opened.

In this case, first turn the mixture control screw counter-clockwise 90° to make sure that the mixture has become richer, then make incremental adjustments, each way, until an acceptable balance between rich v.lean settings is achieved.

Carry out these adjustments patiently under actual running conditions, until the engine responds quickly and positively to throttle movements. Use a small screwdriver to adjust the mixture control valve via its slotted screwhead in the center of the outer end of the throttle rotor.

9. With the optimum mixture control valve position, light smoke is visible during high-speed running and engine rpm increase smoothly during acceleration. Remember that, if the engine is operated with the fuel/air mixture slightly too lean, it will overheat and run unevenly or cut out.

As with all engines, it is wise to set both valves a little on the rich side of the best rpm setting, as a safety measure.

10. When the best balance of mixture adjustments has been determined and, especially as the engine becomes fully run-in, it will probably be found that the idling speed has increased.

Readjust the throttle opening by means of the trim lever on the transmitter, so that the lowest idling speed, without risk of stalling the engine, may be obtained.

WARNING :

For safety reasons, it is advisable to stop the engine before carrying out adjustments to the Mixture Control Screw.

Note :

Once the correct carburetor settings have been established, it should be unnecessary to alter them.

Such slight Needle-Valve readjustments as may be required to compensate for variations in atmospheric conditions will not normally affect the other two controls. Slight readjustments may be necessary for optimum performance if different types of fuel, glowplugs or propellers are used.

CARBURETOR CLEANLINESS

Proper functioning of the carburetor depends on its small fuel orifices remaining clear.

The minute particles of foreign matter that are present in any fuel, can partially obstruct these orifices and upset mixture strength so that engine performance becomes erratic and unreliable.

It is recommended that fuel is passed through a filter when the tank is filled and that a good in-line filter is installed between the fuel tank and carburetor and, furthermore, that this filter is frequently cleaned to remove foreign matter that accumulate on the filter screen.

Finally, occasionally remove the needle-valve holder from the carburetor as shown below and extract any remaining foreign matter that may have lodged in the location shown.

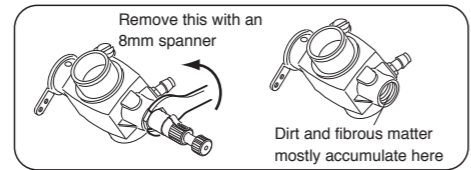

CARE AND MAINTENANCE

1. The minute particles of foreign matter, that are present in any fuel may, by accumulating and partially obstructing fuel flow, cause engine performance to become erratic and unreliable.

O.S. 'Super-Filters' (large and small) are available, as optional extras, to deal with this problem. One of these filters installed to the pickup tube inside your refueling container, will prevent the entry of foreign material into the fuel tank. It is also recommended that a good in-line filter be installed between the tank and carburetor.

2. Do not forget to clean the filters regularly to remove foreign matter that accumulate on the filter screens. Also, clean the carburetor itself occasionally.

3. At the end of each operating session, drain out any fuel that may remain in the fuel tank. Afterwards, energize the glow-plug and try to restart the engine, to burn off any fuel that may remain inside the engine. Repeat this procedure until the engine fails to fire. Do this while the engine is still warm.

4. Then, inject some after-run oil into the engine, and rotate the engine with an electric starter for 4 to 5 seconds to distribute the oil to all the working parts.

Note:

Do not inject after-run oil into the carburetor as this may cause the O-rings inside the carburetor to deteriorate. These procedures will reduce the risks of starting difficulties or corrosion after a period of storage.

O.S. GENUINE PARTS & ACCESSORIES

- SUPER FILTER (L) (72403050)
- LOCK WASHER (10set) M4 (55500003)
- O.S. SPEED SILICONE FUEL LINE (72506100)
- O.S. SPEED PLUG WRENCH (71520100)
- NON-BUBBLE WEIGHT (71531000)
- NON-BUBBLE WEIGHT (S) (71531010)

O.S. SPEED DRIVER TOOLS

Code No.	Description
71410150	O.S. SPEED HEX WRENCH DRIVER 1.5
71410200	O.S. SPEED HEX WRENCH DRIVER 2.0
71410250	O.S. SPEED HEX WRENCH DRIVER 2.5
71410300	O.S. SPEED HEX WRENCH DRIVER 3.0
71411200	O.S. SPEED HEX BALL WRENCH DRIVER 2.0
71411250	O.S. SPEED HEX BALL WRENCH DRIVER 2.5
71412300	O.S. SPEED FLAT HEAD SCREWDRIVER 3.0
71413550	O.S. SPEED NUT DRIVER 5.5
71413600	O.S. SPEED NUT DRIVER 6.0
71413700	O.S. SPEED NUT DRIVER 7.0

Code No.	Description
71414015	O.S. SPEED HEX WRENCH TIP ONLY 1.5
71414020	O.S. SPEED HEX WRENCH TIP ONLY 2.0
71414025	O.S. SPEED HEX WRENCH TIP ONLY 2.5
71414030	O.S. SPEED HEX WRENCH TIP ONLY 3.0
71414120	O.S. SPEED HEX BALL WRENCH TIP ONLY 2.0
71414125	O.S. SPEED HEX BALL WRENCH TIP ONLY 2.5
71414230	O.S. SPEED FLAT HEAD SCREWDRIVER TIP 3.0
71414355	O.S. SPEED NUT DRIVER TIP ONLY 5.5
71414360	O.S. SPEED NUT DRIVER TIP ONLY 6.0
71414370	O.S. SPEED NUT DRIVER TIP ONLY 7.0

ENGINE EXPLODED VIEW & PARTS LIST

* Type of screw

C...Cap Screw M...Oval Fillister-Head Screw
F...Flat Head Screw N...Round Head Screw S...Set Screw

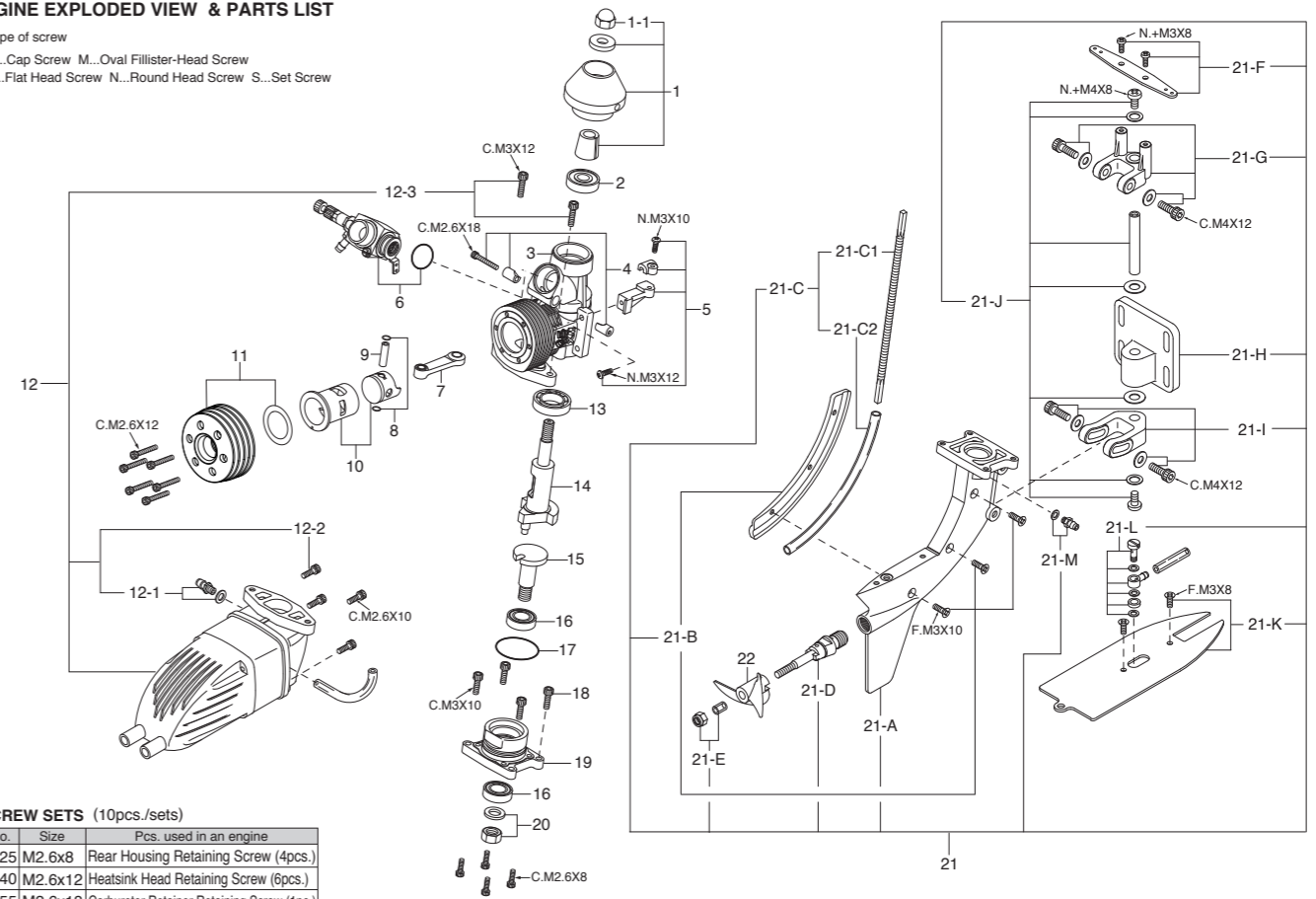

CAP SCREW SETS (10pcs./sets)

Code No.	Size	Pcs. used in an engine
79871025	M2.6x8	Rear Housing Retaining Screw (4pcs.)
79871040	M2.6x12	Heatsink Head Retaining Screw (6pcs.)
79871055	M2.6x18	Carburetor Retainer Retaining Screw (1pc.)

No.	Code No.	Description
1	71802100	Flywheel Assembly (No.2J)
1-1	27721700	Flywheel Nut
2	41614000	Crankshaft Ball Bearing (Front)
3	23851000	Crankcase
4	23981700	Carburetor Retainer
5	71532000	Throttle Linkage Bracket
6	25382000	Carburetor Complete (Type 20J)
7	23755024	Connecting Rod
8	21817000	Piston Pin Retainer (2pcs.)
9	23906000	Piston Pin
10	23853000	Cylinder & Piston Assembly
11	23854000	Heatsink Head Assembly
11-1	23814020	Head Gasket
12	23875010	E-2050-2 Silencer Assembly
12-1	22681953	Nipple No.1
12-2	23875310	Silencer Assembly Screw (4pcs.)
12-3	23875400	Silencer Retaining Screw (2pcs.)
13	23930000	Crankshaft Ball Bearing (Rear)
14	23852010	Crankshaft
15	23852100	Drive Shaft
16	22631019	Drive Shaft Ball-Bearing (1pc.)
17	23814030	Cover Gasket
18	23871140	Rear Housing & Board Unit Retaining Screw (4pcs.)
19	23861000	Rear Housing
20	23852200	Drive Shaft Nut
21	23871010	Outboard Unit Assembly
21-A	23871100	Outboard Unit
21-B	23871200	Side Plate
21-C	23873010	Flexible Wire Assembly
21-C1	23873000	Flexible Wire
21-C2	23873100	Flexible Wire Outer Pipe
21-D	23871400	Propeller Shaft Assembly
21-E	23810000	Propeller Nut
21-F	23874500	Steering Arm
21-G	23874100	Upper Arm
21-H	23874000	Mount Plate
21-I	23874200	Lower Arm
21-J	23874300	Arm Shaft Assembly
21-K	23871300	Cavitation Plate
21-L	45571110	Universal Nipple L3.5
21-M	22681953	Nipple No.1
22	23870000	Marine Propeller
	71608001	Glowplug No.8

CARBURETOR EXPLODED VIEW & PARTS LIST

* Type of screw S...Set Screw

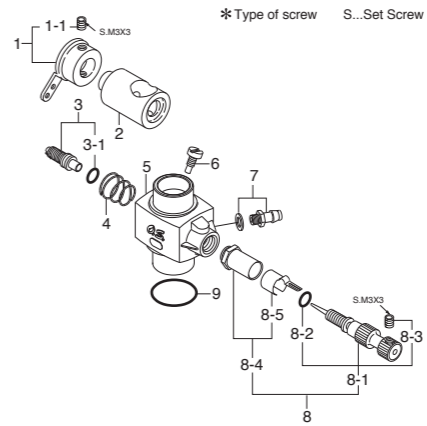

No.	Code No.	Description
1	24981405	Throttle Lever Assembly
1-1	26381501	Set-screw
2	25381203	Carburetor Rotor
3	26781309	Mixture Control Valve
3-1	24881824	"O" Ring (2pcs.)
4	26781506	Rotor Spring
5	25382100	Carburetor Body
6	25381220	Rotor Guide Screw
7	22681953	Fuel Inlet (No.1)
8	27881900	Needle Valve Assembly
8-1	24981959	Needle Assembly
8-2	24981837	"O" Ring (2pcs.)
8-3	26381501	Set-screw
8-4	27381940	Needle Valve Holder Assembly
8-5	26711305	Ratchet Spring
9	29015019	Carburetor Rubber Gasket

THREE VIEW DRAWING

Dimensions (mm)

SPECIFICATIONS

■ Displacement	3.46 cc / 0.211 cu.in.
■ Bore	16.6 mm / 0.654 in.
■ Stroke	16.0 mm / 0.630 in.
■ Output	1.3 ps / 1.28 hp / 25,000 r.p.m.
■ Practical R.P.M.	3,000-25,000 r.p.m.
■ Weight	682 g / 24.0 oz. (Engine)

