

## MAX-15CV EXPLODED VIEW

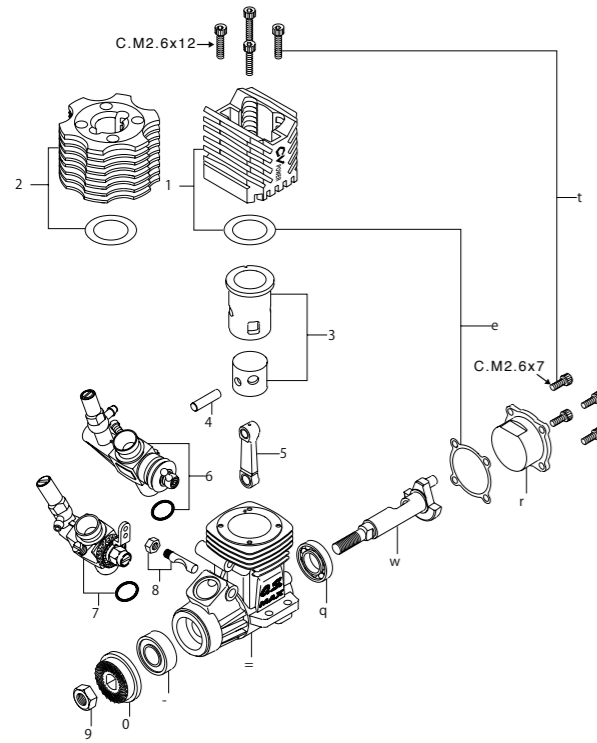

Type of screw C...Cap Screw M...Oval Fillister-Head Screw  
F...Flat Head Screw N...Round Head Screw S...Set Screw

## MAX-15CV ENGINE PARTS LIST

No.	Code No.	Description
1	2 1504 000	Heatsink Head(BLUE)
2	2 1504 200	15CV Machine Head(GOLD)
3	2 1503 000	Cylinder & Piston Assembly
4	2 1706 000	Piston Pin
5	2 1205 040	Connecting Rod
6	2 1286 000	Carburetor Complete (Type 10C)
7	2 1481 020	Carburetor Complete (Type 10E-R)
8	2 1481 700	Carburetor Retainer
9	2 0810 007	Propeller Nut
0	2 1408 000	Drive Hub
-	2 2631 019	Crankshaft Ball Bearing (Front)
=	2 1501 010	Crankcase(GREY)
q	2 1230 000	Crankshaft Ball Bearing (Rear)
w	2 1202 010	Crankshaft
e	2 1514 010	Gasket Set
r	2 1407 010	Cover Plate(GREY)
t	2 1213 000	Screw Set
7 1605 300		Glow Plug A3
7 2403 200		Super Air Cleaner 102(W/3 filter elements)
7 2403 210		102 Cleaner Body
7 2403 120		101,102 Filter Elements (6pcs.)

The specifications are subject to alteration for improvement without notice.

## MAX-15CV-X EXPLODED VIEW

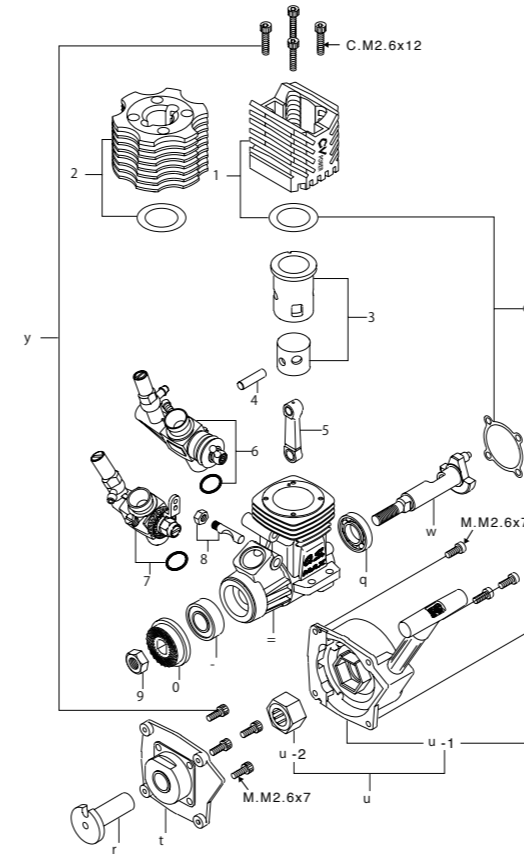

Type of screw C...Cap Screw M...Oval Fillister-Head Screw  
F...Flat Head Screw N...Round Head Screw S...Set Screw

## MAX-15CV-X ENGINE PARTS LIST

No.	Code No.	Description
1	2 1504 000	Heatsink Head(BLUE)
2	2 1504 200	15CV Machine Head(GOLD)
3	2 1503 000	Cylinder & Piston Assembly
4	2 1706 000	Piston Pin
5	2 1205 040	Connecting Rod
6	2 1286 000	Carburetor Complete (Type 10C)
7	2 1481 020	Carburetor Complete (Type 10E-R)
8	2 1481 700	Carburetor Retainer
9	2 0810 007	Propeller Nut
0	2 1408 000	Drive Hub
-	2 2631 019	Crankshaft Ball Bearing (Front)
=	2 1501 010	Crankcase(GREY)
q	2 1230 000	Crankshaft Ball Bearing (Rear)
w	2 1202 000	Crankshaft
e	2 1514 010	Gasket Set
r	2 1421 200	Starting Shaft
t	2 1421 100	Rear Adaptor
y	2 1313 030	Screw Set
u	7 3003 000	No.5 Recoil Starter Assembly
u -1	7 3003 100	No.5 Recoil Starter Body
u -2	7 3003 200	No.5 One-way Clutch
7 2404 000		Engine Mount Spacer
7 1605 300		Glow Plug A3
7 2403 200		Super Air Cleaner 102(W/3 filter elements)
7 2403 210		102 Cleaner Body
7 2403 120		101,102 Filter Elements (6pcs.)

The specifications are subject to alteration for improvement without notice.

## 10C CARBURETOR EXPLODED VIEW & PARTS LIST

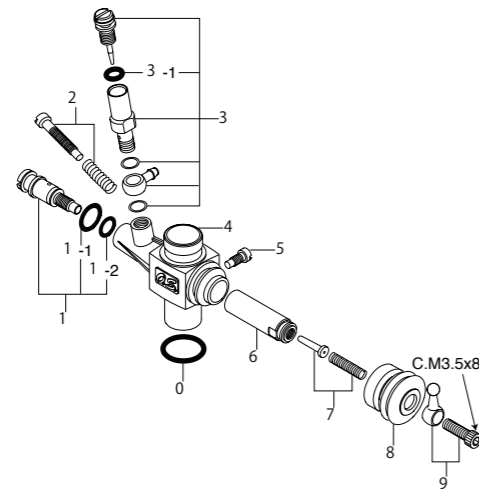

Type of screw C...Cap Screw M...Oval Fillister-Head Screw  
F...Flat Head Screw N...Round Head Screw S...Set Screw

No.	Code No.	Description
1	2 1285 600	Mixture Control Valve Assembly
1 -1	4 6066 319	"O" Ring(L) (2pcs.)
1 -2	2 2781 800	"O" Ring(S) (2pcs.)
2	2 1285 640	Throttle Stop Screw
3	2 1285 901	Needle Valve Assembly
3 -1	2 7881 820	"O" Ring (2pcs.)
4	2 1286 100	Carburetor Body
5	2 1285 220	Slide Valve Guide Screw
6	2 1286 200	Slide Valve
7	2 1286 400	Metering Needle Assembly
8	2 1881 320	Dust Cover
9	2 3818 420	Ball Link No.4
0	2 2615 000	Carburettor Rubber Gasket

The specifications are subject to alteration for improvement without notice.

## 10E-R CARBURETOR EXPLODED VIEW & PARTS LIST

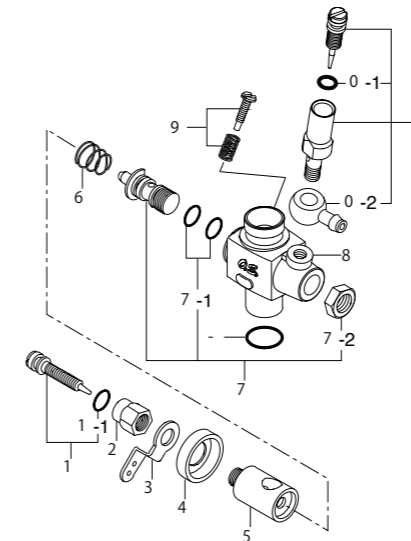

No.	Code No.	Description
1	2 1481 600	Mixture Control Screw
1 -1	2 7881 820	"O" Ring (2pcs.)
2	2 1481 420	Throttle Lever Fixing Nut
3	2 2681 419	Throttle Lever
4	2 1283 210	Dust Cover
5	2 1481 200	Carburetor Rotor
6	2 2481 506	Rotor Spring
7	2 1283 962	Nozzle Assembly
7 -1	2 4881 824	"O" Ring
7 -2	2 1283 961	Locknut
8	2 1481 120	Carburetor Body
9	2 2681 310	Throttle Stop Screw
0	2 1481 900	Needle Valve Assembly
0 -1	2 7881 820	"O" Ring (2pcs.)
0 -2	2 1481 950	Fuel Inlet
-	2 2615 000	Carburetor Rubber Gasket

The specifications are subject to alteration for improvement without notice.