

# MAX-21XZ-R Ver. II

## INSTRUCTION MANUAL

It is of vital importance, before attempting to operate your engine, to read the general '**SAFETY INSTRUCTIONS AND WARNINGS**' section on pages 2-5 of this booklet and to strictly adhere to the advice contained therein.

- Also, please study the entire contents of this instruction manual, so as to familiarize yourself with the controls and other features of the engine.
- Keep these instructions in a safe place so that you may readily refer to them whenever necessary.
- It is suggested that any instructions supplied with the vehicle, radio control equipment, etc., are accessible for checking at the same time.

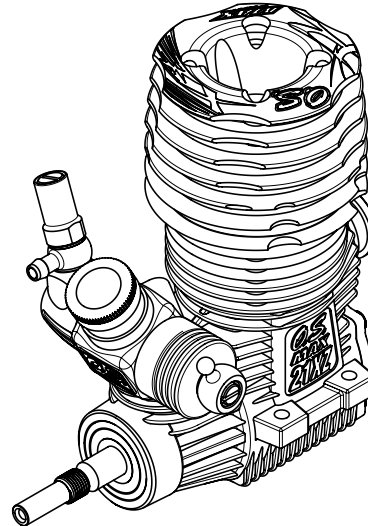

SAFETY INSTRUCTIONS AND WARNINGS ABOUT YOUR O.S. ENGINE -----	2-5	STARTING THE ENGINE & RUNNING-IN ('Breaking-in) -----	18-22
ENGINE CONSTRUCTION, NOTES WHEN APPLYING AN ELECTRIC STARTER -----	6-7	FINAL ADJUSTMENT -----	23-25
NOTES ON OPERATION, ABOUT THE ENGINE -----	8-9	CARE AND MAINTENANCE -----	26-27
TOOLS, ACCESSORIES, etc. BASIC ENGINE PARTS -----	10-12	TROUBLE SHOOTING -----	28-31
INSTALLATION OF THE STANDARD ACCESSORIES, GLOWPLUG -----	13-14	ENGINE EXPLODED VIEW & PARTS LIST ---	32-33
INSTALLATION, CARBURETOR CONTROLS 21M -----	15-17	CARBURETOR EXPLODED VIEW & PARTS LIST ---	34-35
		O.S. GENUINE PARTS & ACCESSORIES -----	36-37
		THREE VIEW DRAWING -----	38

## SAFETY INSTRUCTIONS AND WARNINGS ABOUT YOUR O.S. ENGINE

Remember that your engine is not a "toy", but a highly efficient internal-combustion machine whose power is capable of harming you, or others, if it is misused.

As owner, you, alone, are responsible for the safe operation of your engine, so act with discretion and care at all times.

If at some future date, your O.S. engine is acquired by another person, we would respectfully request that these instructions are also passed on to its new owner.

■ The advice which follows applies basically to ALL MODEL ENGINES and is grouped under two headings according to the degree of damage or danger which might arise through misuse or neglect.



### WARNINGS

These cover events which might involve serious (in extreme circumstances, even fatal) injury.



### NOTES

These cover the many other possibilities, generally less obvious sources of danger, but which, under certain circumstances, may also cause damage or injury.

2



## WARNINGS

• Model engine fuel is poisonous. Do not allow it to come into contact with the eyes or mouth. Always store it in a clearly marked container and out of the reach of children.



• Model engine fuel is also highly flammable. Keep it away from an open flame, excessive heat, sources of sparks, or anything else which might ignite it. Do not smoke or allow anyone else to smoke, near to it.



• Never operate your engine in an enclosed space. Model engines, like automobile engines, exhaust deadly carbon-monoxide. Run your engine only in an open area.

• Model engines generate considerable heat. Do not touch any part of your engine until it has cooled. Contact with the muffler (silencer), cylinder head or exhaust header pipe, in particular, may result in a serious burn.



3



## NOTES

- This engine is intended for model cars. Do not attempt to use it for any other purpose.
- Mount the engine in your model securely, following the manufacturers' recommendations, using appropriate screws and locknuts.
- Install an effective silencer (muffler). Frequent close exposure to a noisy exhaust (especially in the case of the more powerful highspeed engines) may eventually impair your hearing and such noise is also likely to cause annoyance to others over a wide area.
- The wearing of safety glasses is also strongly recommended.
- Take care that the glowplug clip or battery leads do not come into contact with rotating parts. Also check that the linkage to the throttle arm is secure.
- For their safety, keep all onlookers (especially small children) well back (at least 20 feet or 6 meters) when preparing your model for running.



## NOTES

- Before starting the engine, always check the tightness of all the screws and nuts especially those of joint and movable parts such as throttle arm. Missing retightening the loose screws and nuts often causes the parts breakage that is capable of harming you.
- To stop the engine, fully retard the throttle stick and trim lever on the transmitter, or, in an emergency, cut off the fuel supply by pinching the fuel delivery line from the tank.
- Warning! Immediately after a glowplug-ignition engine has been run and is still warm, conditions sometimes exist whereby it is just possible for the engine to abruptly restart if it is rotated over compression WITHOUT the glowplug battery being reconnected.

### ENGINE CONSTRUCTION

With this engine, the piston will feel tight at the top of its stroke (TDC) when the engine is cold. This is normal. The cylinder bore has a slight taper. The piston and cylinder are designed to achieve a perfect running clearance when they reach operating temperature.

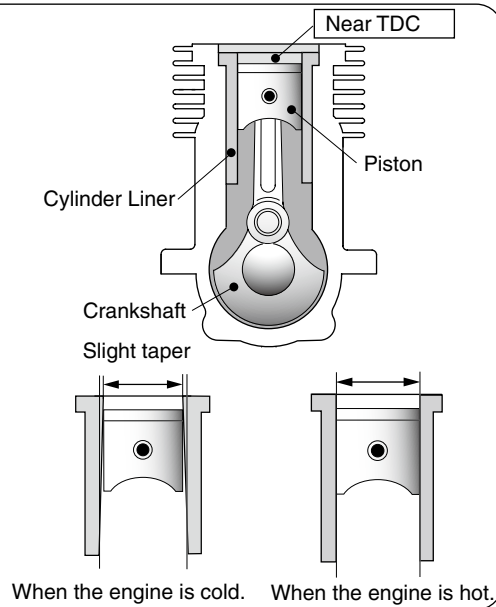

### NOTES WHEN APPLYING AN ELECTRIC STARTER

Do not over-prime. This could cause a hydraulic lock and damage the engine on application of the electric starter.

If over-primed, remove glowplug, close needle-valve and apply starter to pump out surplus fuel. Cover the head with a rag to prevent any pumped out fuel from getting into your eyes.

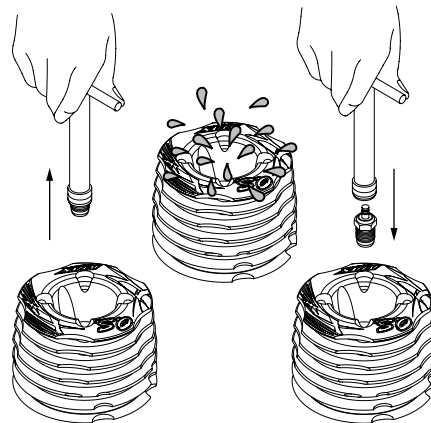

**GUARANTEE**

This engine is constructed from the very best materials available and to the very highest engineering standards, using the most advanced precision machinery. However, the extremely high stresses imposed by car racing operation under very severe conditions, as well as stresses which are exacerbated by the use of powerful fuels containing very high concentrations of nitromethane, constitute hazards which are beyond a manufacturer's control. Accordingly, we regret that it is not possible to extend our usual warranty terms to this particular engine -i.e. no guarantee is offered against material wear, or damage resulting from, actual use.

**While Operating**

- Please do not run on a public street, this could cause serious accidents, personal injuries and/or property damage.
- Please do not run near pedestrians or small children.
- Please do not run in small or confined areas.
- Please do not run where loud noises can disturb others, such as hospitals and residential areas.

**NOTE**

As delivered, the engine has the carburetor lightly fit into its intake. Secure it changing its angle according to the car chassis.

The MAX-21XZ-R Ver.II is expressly designed for 1/8 On-Road Racing. Based on the MAX-21XZ-R, torque characteristics have been improved by modifying the crankcase and carburetor. Also, lighter weight is achieved due to smaller dia. head. O.S. standard of easy to handle characteristics and high performance have been realized.

**Standard accessories**

- Glow Plug RP7 
- T-type head (Turbo head) 1piece
- Exhaust Seal Ring 1piece 
- Cylinder-head gasket (0.2mm) 1 piece 
- Carburetor Reducer 9mm (Blue) 1piece 
- Flywheel No.1E Collet 1piece 
- Dust Cap  $\phi 3, \phi 16, \phi 18$  1piece each



Tools, accessories, etc. The following items are necessary for operating the engine.

■ **Optional Extras**

**SUPER AIR CLEANER 202 ASSEMBLY**

**INDUCTION SILENCER**

**ON-ROAD FILTER OIL (20ml)**

**T-2080SC TUNED SILENCER COMPLETE SET**

This is a set of T-2080SC Tuned Silencer and M2001SC Exhaust Header Pipe Assembly.

**T-2080 TUNED SILENCER COMPLETE SET**

This is a set of T-2080 Tuned Silencer and M2001 Exhaust Header Pipe Assembly.

**PRESSURE CHAMBAR**

This is connected between the fuel tank and the silencer to maintain exhaust pressure.

■ **TOOLS**

**O.S. SPEED DRIVER TOOLS**

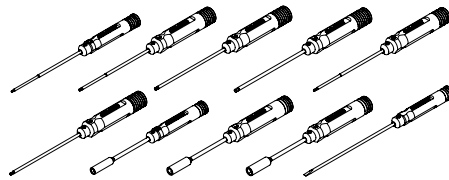

**O.S. SPEED FLYWHEEL KEY**



**O.S. SPEED CLUTCH WRENCH & ADJUSTER**



**O.S. SPEED FLYWHEEL PULLER**

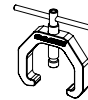

**O.S. SPEED PLUG WRENCH**

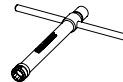

■ **Items necessary for starting**

**FUEL**

Generally, it is suggested that the user selects a fuel that is commercially available for model two-stroke engines. When the brand of fuel is changed, or the nitro content increased, it is advisable to reset the carburetor settings. Please note that with high-nitro fuels, although power may be increased for competition purposes, glowplug elements do not last as long and engine life will be shortened.

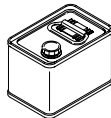

**REMINDER!**

Model engine fuel is poisonous. Do not allow it to come into contact with the eyes or mouth. Always store it in a clearly marked container and out of the reach of children.

Model engine fuel is also highly flammable. Keep it away from open flame, excessive heat, sources of sparks, or anything else which might ignite it. Do not smoke or allow anyone else to smoke, near to it.



**FUEL FILTER**

To be installed in the fuel line between fuel tank and carburetor to prevent dust from entering the carburetor.

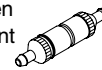

**GLOWPLUG IGNITER**

Commercially available handy glowplug heater in which the glowplug battery and battery leads are integrated.

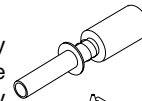

**STARTER BOX**

For starting the engine.

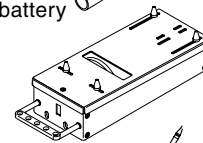

**FUEL PUMP**

For filling the fuel tank, a simple, polyethylene "squeeze" bottle, with a suitable spout, is required.



**SILICONE FUEL LINE**

Heatproof silicone tubing of approx. 5mm o.d. and 2mm i.d. is required for the connection between the fuel tank and engine.



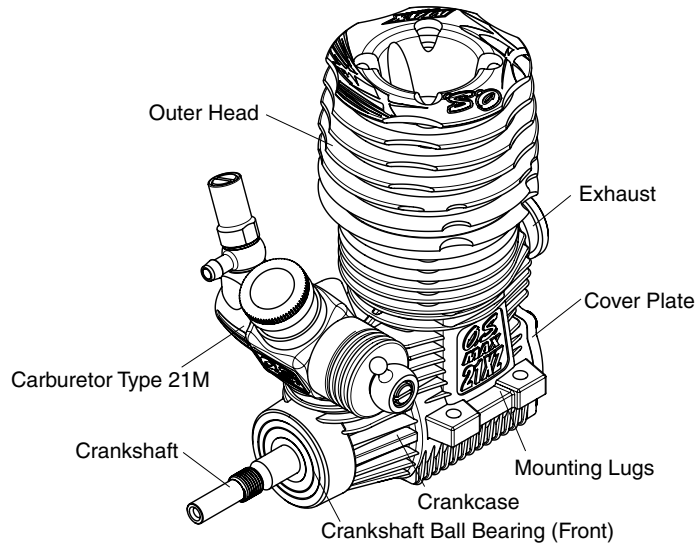

Installing the glow plug. Insert RP7 plug supplied into heat-sinkhead carefully, making sure that it is not cross-threaded before tightening firmly. (All the O.S. T-Type plugs including the RP7 are not supplied with a washer.)

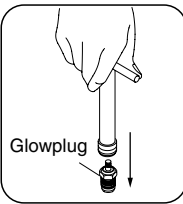

Install the exhaust seal ring supplied.

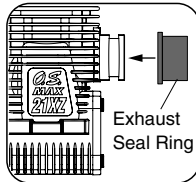

■ Installing the carburetor reducer

Replace the reducer according to the course-conditions.

**8.5mm**

Standard with the carburetor when it leaves the factory.

**9mm** Supplied with the engine.

■ About the Head Gasket

The engine is installed with a 0.1mm thick and a 0.2mm thick gasket for 25% nitro fuel when it leaves the factory. Also, a 0.2mm thick gasket is supplied with the engine as standard. Adjust the total thickness according to atmospheric temperature, humidity and glowplug used.

■ INSTALLATION OF THE TAPER COLLET

Insert the taper collet on the crankshaft, taking care not to push the crankshaft back so that it contacts the coverplate face.

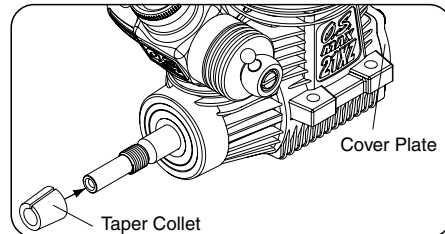



Since the compatibility of the glowplug and fuel may have a marked effect on performance and reliability, it is suggested to use the O.S. RP7 plug when it is necessary to replace. Carefully install plug finger-tight, before final tightening with the correct size plug wrench.

**The role of the glowplug**

With a glowplug engine, ignition is initiated by the application of a 1.5-volt power source. When the battery is disconnected, the heat retained within the combustion chamber remains sufficient to keep the plug filament glowing, thereby continuing to keep the engine running. Ignition timing is 'automatic' : under reduced load, allowing higher rpm, the plug becomes hotter and, appropriately, fires the fuel/air charge earlier; conversely, at reduced rpm, the plug become cooler and ignition is retarded.

**Glowplug life**

Particularly in the case of very high performance engines, glowplugs must be regarded as expendable items. However, plug life can be extended and engine performance maintained by careful use, i.e.:

- Install a plug suitable for the engine.
- Use fuel containing a moderate percentage of nitromethane unless more is essential for racing events.
- Do not run the engine too lean and do not leave the battery connected while adjusting the needle.

**When to replace the glowplug**

Apart from when actually burned out, a plug may need to be replaced because it no longer delivers its best performance, such as when:

- Filament surface has roughened and turned white.
- Filament coil has become distorted.
- Foreign matter has adhered to filament or plug body has corroded.
- Engine tends to cut out when idling.
- Starting qualities deteriorate.

As delivered, the engine has its carburetor lightly installed in the intake boss. Secure it as follows.

1. Loosen the retainer screw, rotate the carburetor to its correct position and make sure that it is pressed well down into the intake boss, compressing the rubber gasket, before retightening screw.
2. Rotate the retainer screw gently until it stops, then tighten a further 120-180°. Do not overtighten the screw as this will damage the thermo insulator.

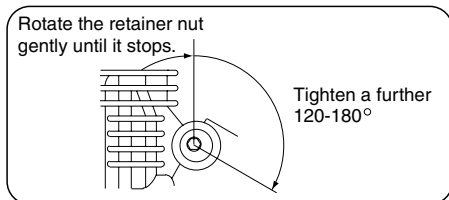

**Note**

**Be careful not to damage the O rings when removing the carburetor retainer from the engine.**

**First, remove the retainer Retaining screw, then pull out each part. Do not push the part in or damage the O rings.**

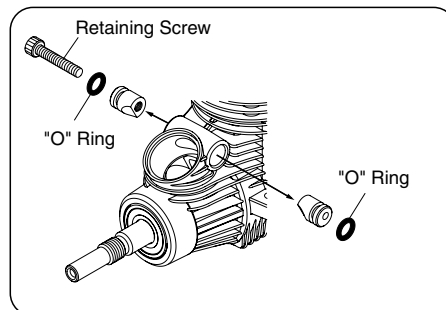



Make sure that the vehicle's engine mounting surfaces are level and in the same plane. Poor installation may cause distortion of the crankcase, bearings, etc., resulting in erratic running and loss of performance.

The recommended screws for securing the engine are 3mm or 4-40 steel Allen hexagon socket type.

If existing holes in the engine mount do not align perfectly with engine mounting lugs, enlarge them slightly with a needle-file so that screws are in alignment with the mounting holes.

Also, make sure the engine does not interfere with chassis, etc.

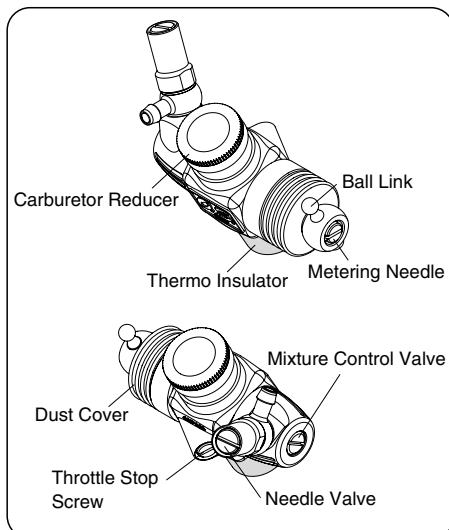
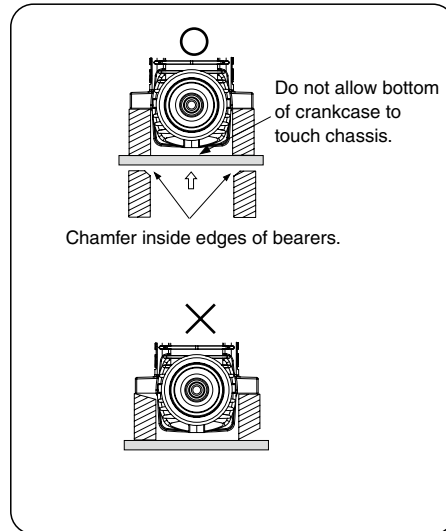

Four adjustable controls are provided on this carburetor.

- **The Needle-Valve(Adjusted at the factory):**  
For adjusting the mixture strength when the throttle is fully open.
- **The Mixture Control Valve:**  
For changing the mixture strength at mid speed and acceleration. (Do not rotate the screw more than one turn.)
- **The Metering Needle:**  
For adjusting the mixture strength at part-throttle and idle speed, to obtain steady idling and smooth acceleration to mid speed.
- **The Throttle Stop Screw (Adjusted at the factory):**  
For setting the minimum idle speed:

**NOTE: Readjustment may be necessary, occasionally to allow for changes in fuel formula, gear ratio or clutch engagement point.**

**⚠ Before starting the engine, always check the tightness of all the screws and nuts especially those of joint and movable parts such as throttle arm. Missing retightening the loose screws and nuts often causes the parts breakage that is capable of harming you.**

**RUNNING-IN ('Breaking-in')**

Running-in is a procedure for an engine to come close to actual running conditions (fuel, r.p.m., engine temperature, etc.). Excessively rich running and prolonged low speed running should be avoided. Prolonged low speed running and low temperature running may result in the oil in the fuel becoming gelled and the piston/liner becoming stuck together.

**PRESSURIZED FUEL SYSTEM**

- The somewhat violent changes of the fuel level in the tank may occur during running due to road surface condition. In addition, the fuel tank is often located some distance from the carburetor. These mean that the fuel 'head' at the carburetor can vary and upset running. Therefore, it is recommended that a muffler pressurized fuel feed system be used.
- Never run your vehicle without installing the air cleaner. Dust and dirt that may otherwise be drawn into the engine will rapidly shorten its life.

**The following procedure is suitable when a fuel containing 25% nitro-methane is used.**

- ◆ Fill the tank completely with fuel.
- ◆ Temporarily remove the glowplug to check that it glows bright red when energized.

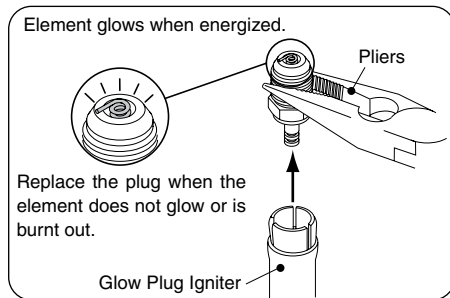

**The carburetor is set at the factory as shown at the right. Start the engine as it is.**

- ◆ The needle-valve is set approx. 3 turns opened from the fully closed position.

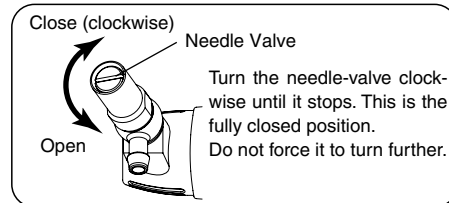

- ◆ Throttle is set approx. 0.5mm open.

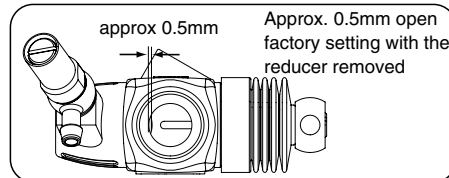

- ◆ Metering needle and mixture control valve are set at basic position. (Refer to P25.)

## 0.5 ENGINE

- ◆ Switch on the transmitter and make sure that each linkage moves correctly.
- ◆ Turn the engine with starter box to draw fuel into the engine.

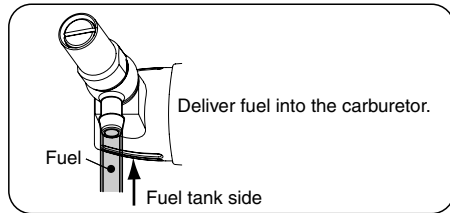

- ◆ Now connect glowplug battery lead to heat the plug filament and start the engine.

### When the engines does not start or stops right after started, try the followings.

- Set the needle-valve approx. 2.5 turns open from the fully closed position.

Do not force the needlevalve to turn beyond a lightly closed position.

- Set the throttle opening a little wider that the factory setting by adjusting the Throttle Stop Screw.

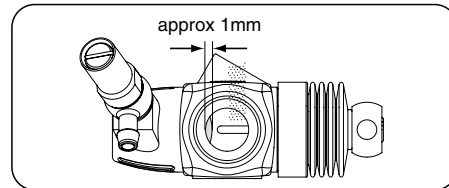

- ◆ When the engine starts, warm it up by repeatedly increasing the rpm to medium speed and back again to a fast idle with the mixture set very rich, the glowplug connected, and the driving wheels clear of the ground. The rich mixture will provide adequate lubrication and cooling indicated by profuse exhaust smoke.

20

## 0.5 ENGINE

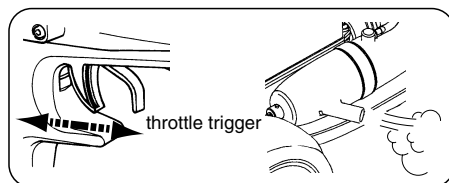

### Attention:

It is vitally important to set the throttle at the correct position before starting the engine. If the engine is allowed to run with the throttle too far open under "no load" conditions (i.e. with the driving wheels not in contact with the ground) it will rapidly over-heat and may be seriously damaged.



- ◆ Next, disconnect the glowplug battery and try running the car on the track.

If the engine stalls, open the throttle fractionally, but try to keep the engine running as rich as possible: if it stops because of being excessively over-rich, close the Needle-Valve 30° and try again.

- ◆ Run the car on the track until one tank of fuel has been consumed, then close the Needle-Valve 10-15° and run the car for 1 to 2 full tanks of fuel.

Repeat this procedure until approx. 2 liters of fuel have been consumed, during which time the throttle may be opened for brief bursts of increased power.

If the engine stops at medium speeds, close the Mixture Screw 45°.

21

The position of the needle-valve when starting the engine.

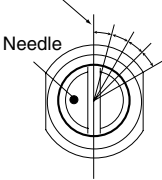

Close the needle-valve approx. 15° after running the vehicle for 1 to 2 full tanks of fuel. Repeat this procedure until approx. 2 liters of fuel have been consumed.

**Note:**  
In the event of any major working parts (e.g. piston/cylinder liner assembly) being replaced or the fuel being changed, especially to high nitro fuel, the complete running-in should be repeated.

■ **How to stop the engine**

To stop the engine, close the throttle to idle speed and shut it off completely with the trim lever on the transmitter then cut off the fuel supply by pinching the fuel delivery tube to the carburetor.

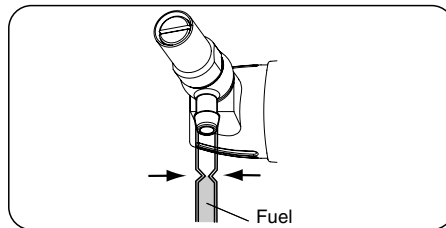

**Warning!**  
Do not touch rotating parts, engine and silencer when stopping the engine as they become very hot, and contact with them may result in a serious burn.

**FINAL ADJUSTMENT**

Final adjustment should be carried out only after the running-in has been completed.

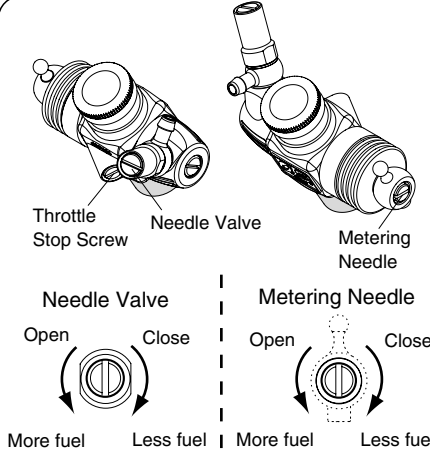

Throttle Stop Screw    Needle Valve    Metering Needle

Needle Valve    Metering Needle

Open    Close    Open    Close

More fuel    Less fuel    More fuel    Less fuel

- ◆ Run the vehicle (with throttle fully open) over the longest available straight course, in order to observe the model's speed. Next return the car to the starting point, close the Needle-Valve 10-15° and repeat the run, taking note of the improvement in performance.
- ◆ Continue with further runs, gradually reducing the Needle-Valve setting and aiming to achieve the highest straight-line speed. Remember, however, that, if the Needle-Valve is shut down too far, the engine will overheat and, accompanied by visibly diminished exhaust smoke, the model will lose speed. At this point, throttle down immediately, stop the vehicle and reopen the Needle-Valve 30°.

- ◆ With the engine running, close the throttle and allow it to idle for about five seconds, then reopen the throttle fully. If, at this point, the engine puffs out an excessive amount of smoke and the vehicle does not accelerate smoothly and rapidly, it is probable that the idle mixture is too rich.
- ◆ In this case, turn the Metering Needle clockwise 30-45°. If, on the other hand, the engine tends to speed up momentarily and then cut out abruptly when the throttle is opened, the idle mixture is too lean. Correct this by turning the Metering Needle counter-clockwise 30-45°.
- ◆ Carry out adjustments patiently, under actual running conditions, until the engine responds quickly and positively to the throttle control.

**Warning!**

**Mixture adjustments (whether via the Metering Needle, or the Needle-Valve) cannot be made accurately under 'no-load' conditions, which, in any case, are not advised, since such operation carries the risk of seriously damaging the engine through over-revving and overheating.**

- ◆ With the optimum mixture control position, light smoke is visible during high speed running, and the engine rpm increases smoothly during acceleration. Remember that, if the engine is operated with the fuel/air mixture slightly too lean, it will overheat and run unevenly. As with all engines, it is advisable to set both the needle-valve and metering needle slightly on the rich side of the best rpm setting, as a safety measure.

- ◆ If the engine runs too fast with the throttle closed, the throttle stop screw should be turned counter-clockwise to allow the throttle opening to be reduced.
- ◆ Finally, beyond the nominal break-in period, a slight readjustment toward a leaner needle setting may be required to maintain maximum performance.

**REALIGNMENT OF METERING NEEDLE AND MIXTURE CONTROL VALVE**

In the course of making carburetor adjustments, it is just possible that the Metering Needle and the Mixture Control Valve may be inadvertently screwed in or out too far and thereby moved beyond its effective adjustment range. The basic positions can be found by rotating the Metering Needle until its slotted head is flush with the ball link body.

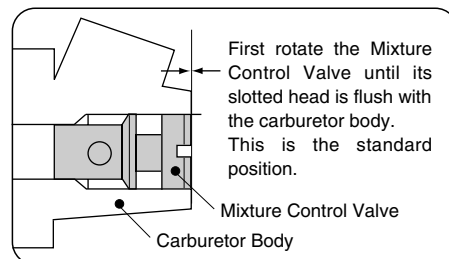
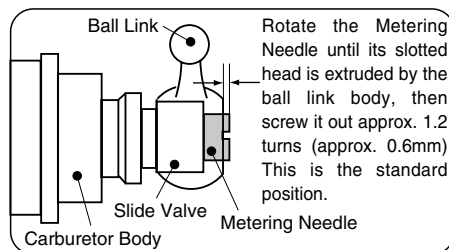

1. The minute particles of foreign matter, that are present in any fuel may, by accumulating and partially obstructing fuel flow, cause engine performance to become erratic and unreliable. O.S. 'Super-Filters' (large and small) are available, as optional extras, to deal with this problem. One of these filters installed to the pickup tube inside your refueling container, will prevent the entry of foreign material into the fuel tank. It is also recommended that a good in-line filter be installed between the tank and carburetor.
2. Do not forget to clean the filters regularly to remove dirt and lint that accumulate on the filter screens. Also, clean the carburetor itself occasionally.

3. At the end of each operating session, drain out any fuel that may remain in the fuel tank. Afterwards, energize the glow-plug and try to restart the engine, to burn off any fuel that may remain inside the engine. Repeat this procedure until the engine fails to fire. Do this while the engine is still warm.
4. Then, inject some after-run oil into the engine, and rotate the engine with an electric starter for 4 to 5 seconds to distribute the oil to all the working parts.

**Note:**

**Do not inject after-run oil into the carburetor as this may cause the O-rings inside the carburetor to deteriorate. These procedures will reduce the risks of starting difficulties or corrosion after a period of storage.**

**Note:**

**Crankshaft of this engine is filled with silicone. Do not use light oil nor kerosene, etc. for washing, or the silicone will swell. Use alcohol or fuel for washing.**

5. Finally, when cleaning the exterior of the engine, use methanol or a household cleaning agent. Do not use gasoline, kerosene, or any petroleum based chemical which can damage silicone fuel tubing.

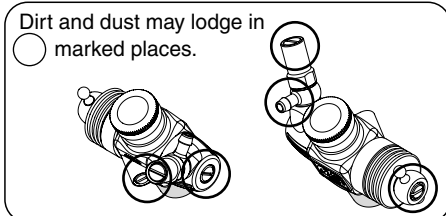

■ **Installing Dust Caps**

When storing the engine, install the cap on the exhaust port, carburetor, etc. to prevent dust from entering the engine.

■ **CHECKING THE ENGINE**

Engine will not develop normal performance after long time running due to wearing of parts. It is suggested to replace necessary parts when the following symptoms are detected.

- ◆ Engine sound changes and easily overheats.
- ◆ Power has dropped extremely.
- ◆ Idling is unstable and/or engine tends to stop at idling.

In most cases, ball bearings, cylinder & piston assembly, connecting rod and/or crankcase have become worn out or abnormal. Check the parts carefully and replace them if necessary.

<b>Symptom</b>	
<b>Engine fails to fire.</b>	
<b>Cause</b>	<b>Corrective action</b>
Fuel tank is empty. Fuel not reaching the engine.	Fill the tank with fuel and repeat Priming procedure.
Glowplug element is burnt out. Glowplug battery discharged	Replace glowplug. Recharge or replace the battery.
Clogged fuel filter Air cleaner and silencer inside is dirty.	Clean or replace fuel filter. Replace cleaner element and clean inside silencer.
Over priming	Remove glowplug and pump out excess fuel.
Fuel tubing is disconnected. Fuel tubing is kinked, split or has a hole.	Connect fuel tubing securely. Check the tubing carefully and replace if necessary.
Incorrect servo linkage	Connect correctly after setting servo at neutral.
Reverse rotating direction of starter box.	Make sure it rotates counter clockwise seen from crankshaft side.

<b>Symptom</b>	
<b>Engine fires intermittently but does not run.</b>	
<b>Cause</b>	<b>Corrective action</b>
Insufficient fuel in the tank.	Fill the tank with fuel.
Deteriorated glowplug	Replace glowplug.
Clogged fuel filter Air cleaner and silencer inside is dirty.	Clean or replace fuel filter. Replace cleaner element and clean inside silencer.
Engine overheated	Wait until engine is cool.
Incorrect clutch release	Adjust the tension of clutch spring.
Starting battery disconnected too soon.	Do not disconnect plug battery and wait until r.p.m. becomes stable.
Vibration causing air bubbles in fuel.	Install "O" rings to the tank screws to prevent bubbles.

**0.S. ENGINE**

<b>Symptom</b>	
<b>Unstable idle</b>	
<b>Cause</b>	<b>Corrective action</b>
Unsuitable glowplug	Use suggested glowplug in the instructions.
Unsuitable fuel	Do not use extremely high nitro or low oil content fuel.
Extremely light flywheel	Add heavier flywheel.
Silencer is disconnected or has play	Install silencer securely.
<b>Symptom</b>	
<b>Not reaching expected peak r.p.m.</b>	
<b>Cause</b>	<b>Corrective action</b>
Insufficient warming up or running-in.	Set the needle only after warming up. Complete running-in.
Silencer or manifold is not securely connected or disconnected.	Replace seal ring. Check the connections and secure them.
Fuel tubing from tank is split or broken.	Replace the tubing.

30

**0.S. ENGINE**

<b>Symptom</b>	
<b>Poor response</b>	
<b>Cause</b>	<b>Corrective action</b>
Deteriorated glowplug	Replace glowplug.
Incorrect carburetor settings	Readjust low r.p.m. range with metering needle and mixture control valve.
Incorrect setting of transmitter Exponential function.	Check the transmitter setting.
Incorrect linkage	Make sure the throttle servo linkage does not bind and is connected correctly.
<b>Symptom</b>	
<b>Poor r.p.m. drop</b>	
<b>Cause</b>	<b>Corrective action</b>
Throttle position open too far.	Close metering needle to adequate position to lower idle r.p.m.
Carburetor not fully seated	Install carburetor securely.
Metering needle closed too far.	Open the metering needle a little.

31



No.	Code No.	Description
1	22014020	Outer Head
2	22014100	Inner Head
3	22014160	Head Gasket Set (0.2mm)
4	22014170	Head Gasket Set (0.1mm)
5	22013030	Built-Up Parts Set
5-1	22013000	Cylinder & Piston Assembly
5-2	22016000	Piston Pin
5-3	21817000	Piston Pin Retainer (2pcs.)
5-4	23755020	Connecting Rod
6	22082010	Carburetor Complete (Type 2.1M)
7	23981740	Carburetor Retainer Assembly
7-1	24881824	"O" Ring (2pcs.)
8	23731000	Crankshaft Ball Bearing (Front)
9	22011010	Crankcase
10	23730020	Crankshaft Ball Bearing (Rear)
11	22012000	Crankshaft
12	23764020	Cover Gasket
13	22417000	Cover Plate
	71642070	Glow Plug RP7
	22014160	Head Gasket Set (0.2mm)
	22826140	Exhaust Seal Ring (2pcs.)
	71533010	Carburetor Reducer 9mm (Blue) w/"O" Ring
	22615000	"O" Ring
	71801100	Flywheel No.1E Collet
	22884250	Dust Cap Set ( 3mm, 16mm, 18mm)

The specifications are subject to alteration for improvement without notice.

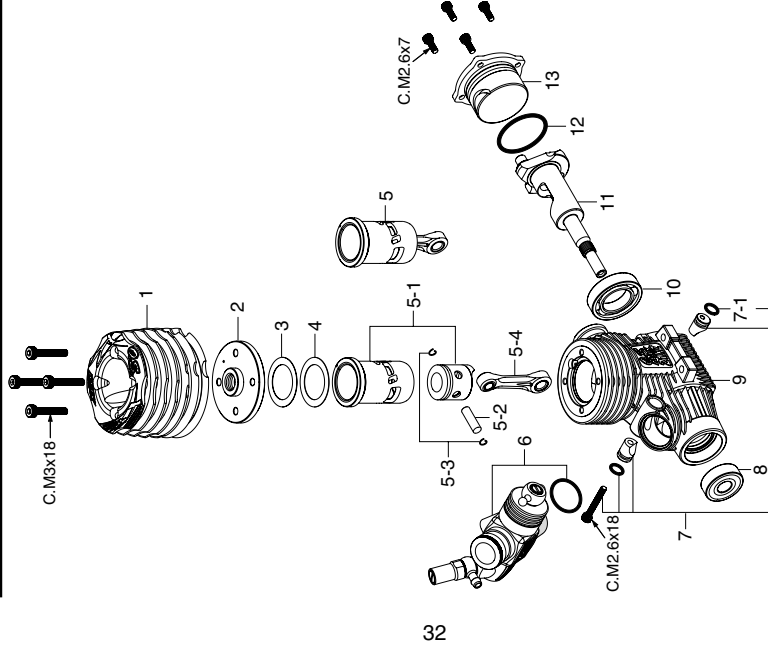

**CAP SCREW SETS (10pcs./sets)**

Code No.	Size	Pcs. used in an engine
79871020	M2.6x7	Cover Plate Retaining Screw (4pcs.)
79871055	M2.6x18	Carburetor Retainer Retaining Screw (1pc.)
79871180	M3x18	Cylinder Head Retaining Screw (4pcs.)

\* Type of screw  
C···Cap Screw

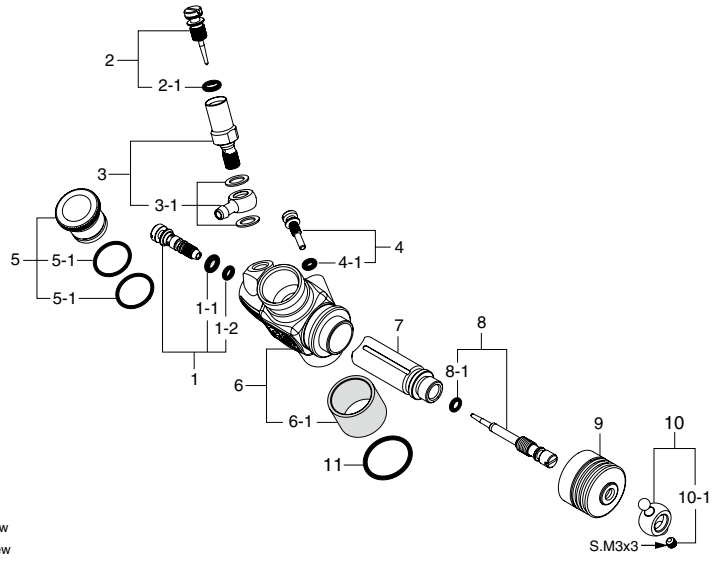

\*Type of screw  
S...Set Screw

No.	Code No.	Description
1	22082600	Mixture Control Valve Assembly
1-1	46066319	"O" Ring (L) (2pcs.)
1-2	22781800	"O" Ring (S) (2pcs.)
2	22082970	Needle Assembly
2-1	46066319	"O" Ring (2pcs.)
3	22082940	Needle Holder Assembly
3-1	22082950	No.15 Universal Nipple Assembly
4	22848160	Throttle Stop Screw
4-1	27881820	"O" Ring (S) (2pcs.)
5	71533385	Carburetor Reducer (8.5mm Purple)
5-1	22615000	"O" Ring (1pc.)
6	22082100	Carburetor Body (w/Thermo Insulator)
6-1	23781110	Thermo Insulator
7	22082200	Slide Valve
8	22082350	Metering Needle Assembly
8-1	27881820	"O" Ring (S) (2pcs.)
9	23981520	Dust Cover
10	23781400	Ball Link No.3
10-1	26381501	Set Screw
11	29015019	Carburetor Rubber Gasket

The specifications are subject to alteration for improvement without notice.

■ **GLOWPLUG**

- RP6 (71642060)
- RP7 (71642070)
- RP8 (71642080)



■ **T-2080 TUNED SILENCER COMPLETE SET**

- (72106800)
- T-2080 Tuned Silencer Assembly (72106810)
  - Silencer Ring (21) Set (W/Ring 2pcs./Silencer C Spring 1pc.) (72106820)
  - Silencer C Spring (21) (3pcs.) (72106830)
  - Adapter Seal Ring (2pcs.) (22826140)

- M2001 Exhaust Header Pipe Assembly (72106860)
- Header Pipe Spring (2pcs.) (72101272)
- Exhaust Seal Ring (2pcs.) (22826140)

■ **T-2080SC TUNED SILENCER COMPLETE SET**

- (72106850)
- T-2080SC Tuned Silencer Assembly (72106851)
    - Joint Spring (3pcs.) (72106042)
    - Exhaust Seal Ring (2pcs.) (22826140)
  - M2001SC Exhaust Header Pipe Assembly (72106870)
    - Header Pipe Spring (2pcs.) (72101272)
    - Exhaust Seal Ring (2pcs.) (22826140)

■ **PRESSURE CHAMBER SET**

(71550000)

■ **INDUCTION SILENCER**

- (72414000)
- Induction Silencer Filter (3pcs.) (72414100)

■ **ON-ROAD FILTER OIL**

**(20ml)**  
(72414200)

■ **SUPER AIR CLEANER 202 ASSEMBLY**

- On-road Type (72412000)
- 202 Cleaner Body (72412100)
  - 202 Filter Element (4pcs.) (72412200)

■ **DUST CAP SET**

- **3mm** (5pcs.) (73300305)
- **16mm** (3pcs.) (73301612)
- **18mm** (3pcs.) (73301812)

■ **O.S. SPEED DRIVER TOOLS**

Code No.	Description
71410150	O.S. SPEED HEX WRENCH DRIVER 1.5
71410200	O.S. SPEED HEX WRENCH DRIVER 2.0
71410250	O.S. SPEED HEX WRENCH DRIVER 2.5
71410300	O.S. SPEED HEX WRENCH DRIVER 3.0
71411200	O.S. SPEED HEX BALL WRENCH DRIVER 2.0
71411250	O.S. SPEED HEX BALL WRENCH DRIVER 2.5
71412300	O.S. SPEED FLAT HEAD SCREWDRIVER 3.0
71413550	O.S. SPEED NUT DRIVER 5.5
71413600	O.S. SPEED NUT DRIVER 6.0
71413700	O.S. SPEED NUT DRIVER 7.0

■ **O.S. SPEED CLUTCH WRENCH & ADJUSTER**  
(71415300)

■ **O.S. SPEED FLYWHEEL KEY**  
(71415200)

■ **O.S. SPEED FLYWHEEL PULLER**  
(71415100)

■ **O.S. SPEED PLUG WRENCH**  
(71520100)

Code No.	Description
71414015	O.S. SPEED HEX WRENCH TIP ONLY 1.5
71414020	O.S. SPEED HEX WRENCH TIP ONLY 2.0
71414025	O.S. SPEED HEX WRENCH TIP ONLY 2.5
71414030	O.S. SPEED HEX WRENCH TIP ONLY 3.0
71414120	O.S. SPEED HEX BALL WRENCH TIP ONLY 2.0
71414125	O.S. SPEED HEX BALL WRENCH TIP ONLY 2.5
71414230	O.S. SPEED FLAT HEAD SCREWDRIVER TIP 3.0
71414355	O.S. SPEED NUT DRIVER TIP ONLY 5.5
71414360	O.S. SPEED NUT DRIVER TIP ONLY 6.0
71414370	O.S. SPEED NUT DRIVER TIP ONLY 7.0

The specifications are subject to alteration for improvement without notice.

**SPECIFICATIONS**

■ Displacement	3.49 cc (0.213 cu.in.)
■ Bore	16.27 mm (0.640 in.)
■ Stroke	16.8 mm (0.661 in.)
■ Practical R.P.M.	4,000-45,000 r.p.m.
■ Power output	2.75 ps / 2.79 hp / 33,000 r.p.m.
■ Weight	343 g (12.08 oz.)

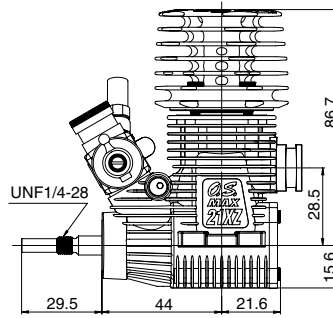
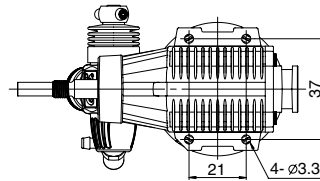
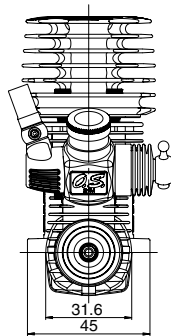

Dimensions (mm)

38



**O.S. ENGINES MFG. CO., LTD.**  
 URL : <http://www.os-engines.co.jp>

6-15 3-Chome Imagawa Higashiumiyoshi-ku  
 Osaka 546-0003, Japan TEL. (06) 6702-0225  
 FAX. (06) 6704-2722