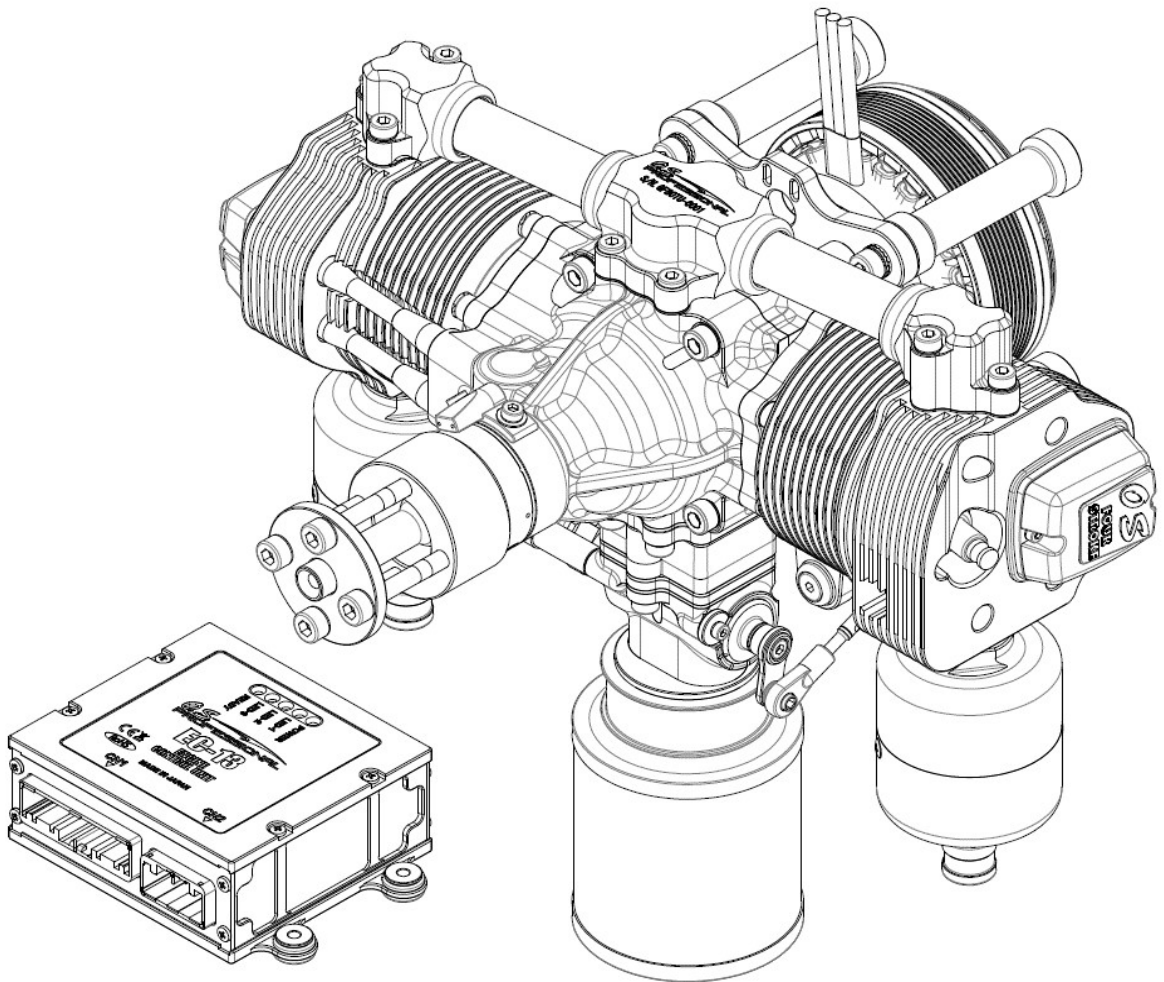

4 stroke gasoline engine for UAV

GF80TU-FI With SGM

With EC-13 (ECU)

INSTRUCTION MANUAL

version 1.2E
2025.02.01



O.S. ENGINES MFG. CO., LTD.

Table of contents

	Page
About the engine	2
Names of the parts	3
Accessories	7
Standard screw tightening torque	10
Installation	
Standoff engine mount	11
Fuel delivery	13
Silencer	16
Propeller	17
Plug cap	18
ECU (Engine Control Unit)	
ECU Wiring harness	19
Preparation (EC13-LINK)	23
Operation (EC13-LINK)	24
SGM(Starter Generator Motor)	
System configuration	33
Connection	34
Operation	
Starting the engine	38
Choke	40
Stopping the engine	41
Restarting ECU	43
ECU Communication protocol	
Serial communication	44
CAN communication	45
ECU connector pin assignment	51
Engine parts list	53
Measurements	62

About the engine

- Please read this instruction manual and all attached instructions carefully before handling the engine.

【ENGINE】

- The engine is equipped with electronic fuel injection system to correspond to environmental changes during a long flight.
- This is a four stroke gasoline engine, but runs on a premixed gasoline/2-stroke engine oil.
- Use high quality commercially available 2-stroke engine oil(JASO FD/ISO-L-EGD).
- The oil to be mixed with gasoline should be commercially available 2-stroke engine oil. Follow the oil manufacture's recommendations regarding the fuel and oil mixture ratios. If there is no recommendation, we recommend 50:1 mixture ratio.
- Adopted a crank chamber pressure supercharging method that utilizes the change in the volume of the crank chamber as the piston moves up and down. As a result, both the low fuel consumption of a 4-stroke engine and the high output of a 2-stroke engine are achieved.
- The engine runs counter-clockwise when viewed from the front.
- Recommended propellers are 22x8-12, 23x8-12, 24x8-10 (DxP Inch). We recommend a propeller whose rpm is within range of 6500rpm~8000rpm at full throttle.
- SGM (starter generator motor) is directly mounted on the crank shaft behind the engine. It is a 200W class generator (Max. 200W/20min. Constant rating: 120W) and has the ability as a cell starter at the time of starting.
 - Although the starter is a starter motor system, it can also be started by a starter. If the voltage of the battery for the starter motor drops, it may not be possible to crank the engine. In that case, please start with an external starter separately.
- Periodical inspection after 50, 100 hours are necessary. Follow the maintenance manual, which is 【ECU (Engine Control Unit)】
- The EC-13 is an engine control unit (ECU), which contains a 32-bit CPU. It collects the data of throttle opening, rpm, induction manifold pressure, atmospheric pressure, induced air temperature, cylinder head temperature and run the engine in the most suitable condition.
- ECU internal information such as engine speed, cylinder head temperature, throttle opening, fuel pressure, etc. can be output to the outside of the ECU in real time by CAN and serial communication.
- The EC13-LINK software, which enables to change the parameters and to monitor the data in real time in Windows® platform, is included as a standard accessory.

CAUTION:

- After overhauling the engine, after disconnecting the throttle linkage, reset the throttle position using the EC13-LINK.

*The specifications are subject to alteration for improvement without notice.

*Consult us for any questions on this product and return for repair.

*This instruction manual was created based on the product specifications as of August 2024.

O.S. ENGINES MFG.CO.,LTD.

6-15 3-Chome Imagawa Higashisumiyoshi-ku

Osaka 546-0003, Japan

TEL.+81-6-6702-0225

FAX.+81-6-6704-2722

<http://www.os-engines.co.jp>

Names of the parts

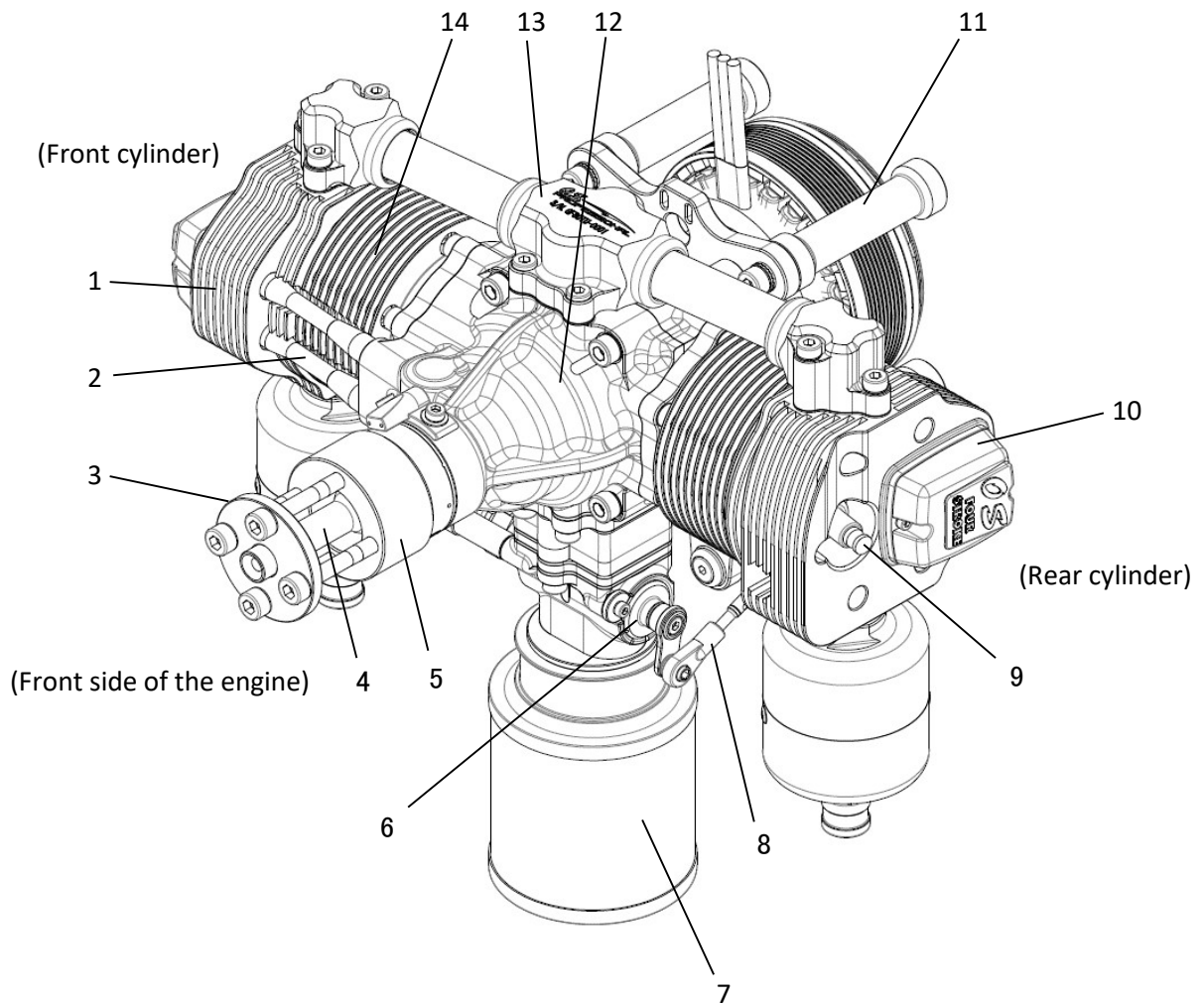

1. Cylinder head
2. Push rod cover
3. Propeller washer
4. Pilot shaft
5. Drive spacer
6. Throttle valve
7. Air cleaner
8. Throttle linkage rod
9. Spark plug (CM-6)
10. Rocker cover
11. Stand off engine mount
12. Crankcase (Front housing)
13. Intake manifold
14. Cylinder

Names of the parts

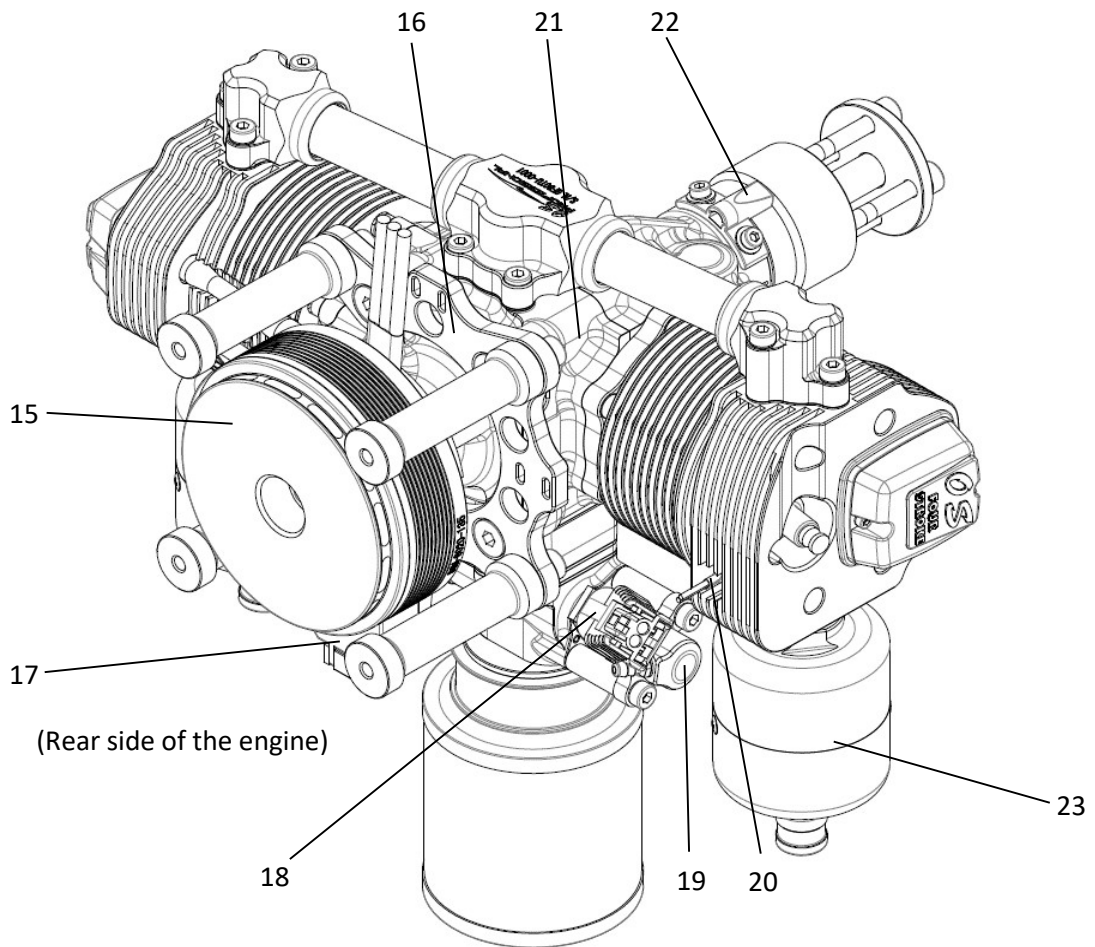

- 15. Starter generator motor (SGM)
- 16. Mounting plate
- 17. Throttle servo
- 18. Injector & connector (Injector harness)
- 19. Injector coupler
- 20. Cylinder head temperature sensor
- 21. Crankcase (Rear housing)
- 22. Crankshaft rotation sensor
- 23. F-6050 Silencer

Names of the parts

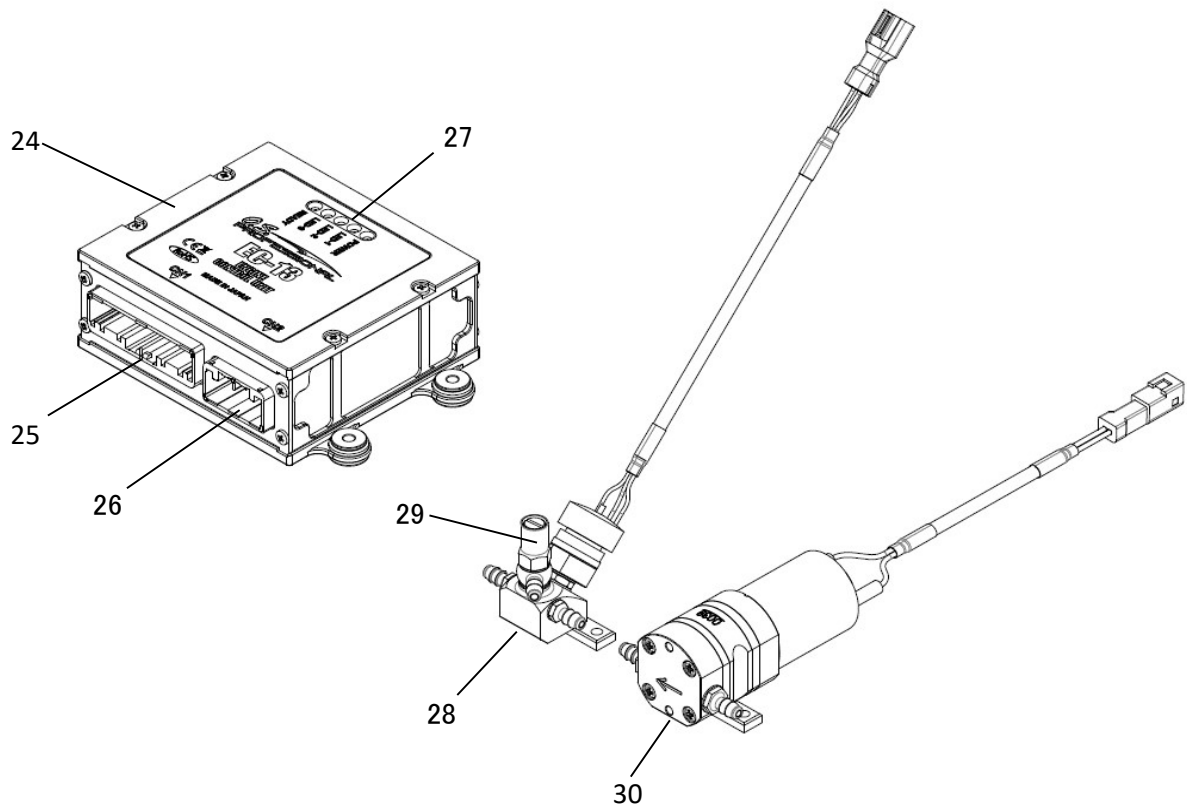

- 24. Engine control unit (ECU)
- 25. ECU connector [CN1]
- 26. ECU connector [CN2]
- 27. Status display LED
- 28. Fuel pressure sensor unit
- 29. Pressure release valve
- 30. Fuel pump unit

Names of the parts

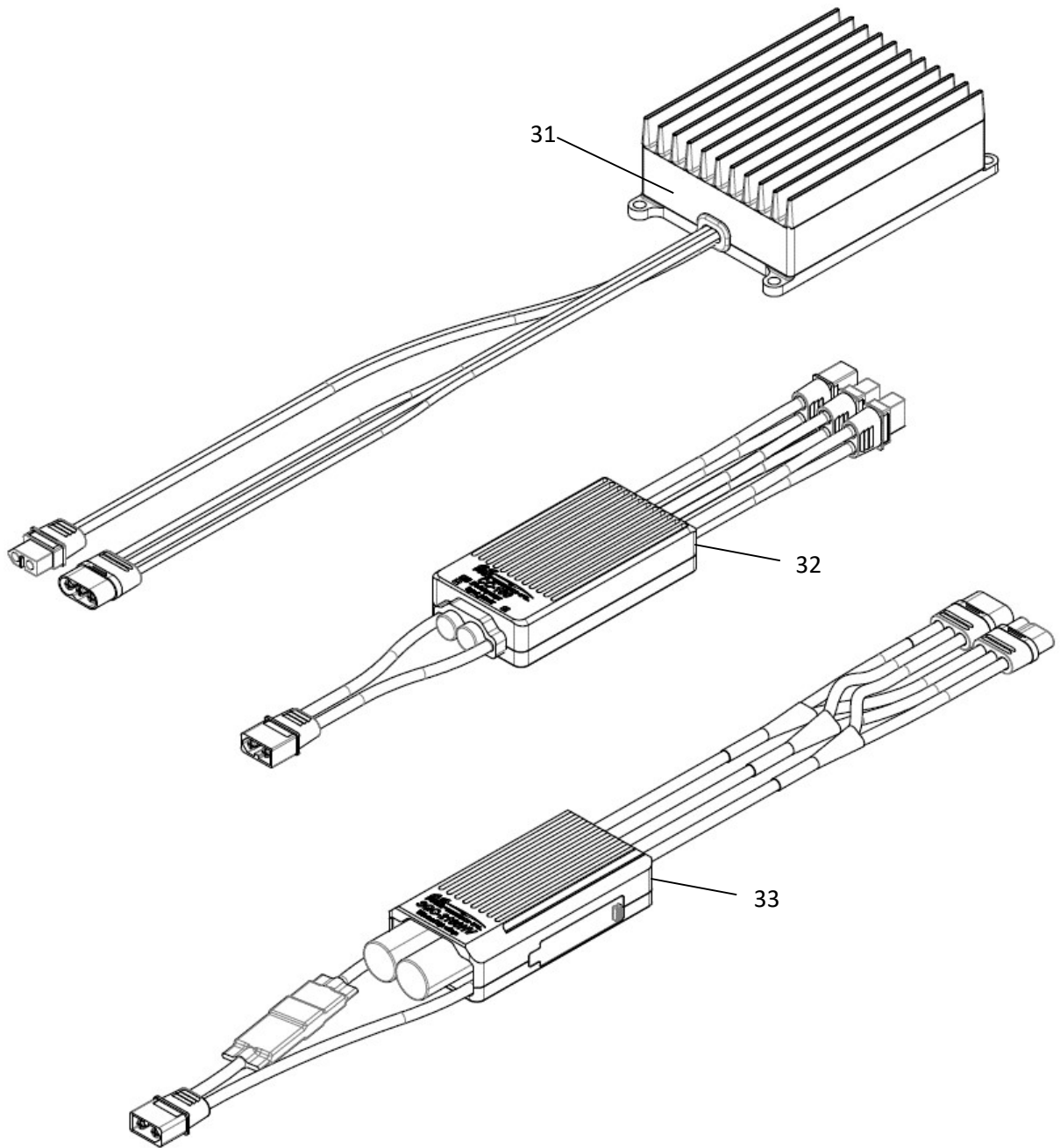

- 31. Regulator rectifier (ORF-200 FOR SGM)
- 32. 4S Li-Po Battery charger (CC-100(4S))
- 33. ESC for SGM (SGC-2100HV)

Accessories



【ECU】 Model: IG-13
• Engine Control Unit(ECU)



【ECU WIRING HARNESS】
• Wiring harness that connect ECU and the engine.



【PUMP CONNECTION CORD】
• Connect the ECU to the fuel pump and fuel pressure sensor unit.
• Install the fuel pump and fuel pressure sensor unit near the fuel tank.



【CAN communication code】
• the connector for CAN communication.
• Connector is JST SMR-04V-B



【FUEL PUMP UNIT】 Model: PM-02A
• Fuel is pumped from the tank.



【FUEL PRESSURE SENSOR UNIT】 Model: SP-01
• Comes with a sensor that measures fuel pressure and a RELEASE VALVE that bleeds air.



Accessories



【Igniter】 Model: IG-12

- The red connector is a power connector. Supply DC6V~16.8V (MAX1A) for operation. The igniter requires a separate power source from that of the ECU. Install a power switch outside of a fuselage between Igniter and power source for safety.
- Connect the black connector to Ignition signal cable of ECU



【Spark plug】 Model: NGK CM-6 (2PCS)

- Screw into the engine's cylinder head.
- the hexagon size is 14mm.
- Tightening torque is 12N·m



【Connector lock】 (3PCS)

- For crankshaft rotation sensor, the power connector of Igniter, and Ignition signal connector to prevent connectors from disconnecting.



【FLUORINE (ETFE) RESIN TUBING】 (2m)

- Be sure to use this high pressure fuel tube for the fuel tube where positive pressure is applied.
- We also sell as parts.
Code No.28382303 FLUORINE(ETFE) RESIN TUBING (2m)



【Hose clamp】 (6PCS)

- To be used to fix pressurized tubes to joints.



【Non-bubble weight】

- Non-bubble weight to be used in a fuel tank to avoid air bubbles in fuel line.
- * For details on how to use, see the section on mounting in the manual.



【Fuel filter】

- Inline fuel filter to be used between a fuel tank and a pump. The arrow mark shows the direction of fuel flow.
- * For details on how to use, see the section on mounting in the manual.

Accessories



【Regulator rectifier】 Model : ORF-200(FOR SGM)

- The output voltage is adjusted to 18V. Please do not change.
- The MR60 (M) connector connects to SGC-2100HV.
- The XT60(F) connector connects to and CC-100.

*See the SGM(Starter Generator Motor) section of this manual for connection details.



【SGC(ESC)】 Model : SGC-2100HV

- It is an ESC with a high withstand voltage specification with a controller for SGM.
- The MR60 (F) connector connects to the ORF-200.
- The MR60 (M) connector connects to SGM-8020.

*See the SGM(Starter Generator Motor) section of this manual for connection details.



【4S Li-Po Battery charger】 Model : CC-100(4S)

- It is a charger for 4S Li-Po battery.
- CC charge: MAX 3A / CV charge: 16V.
- Compatible with 4S Li-Po batteries with capacities of 3000mAh to 4000mAh.
- It does not come with balance charging function.

*See the SGM(Starter Generator Motor) section of this manual for connection details.



【F-6050 Silencer】 Model : F-6050 (2PCS)

- Compact silencer.



【ALUMINUM SPINNER】

- A type of spinner that is used by covering the propeller washer after installing the propeller.



【Socket wrench (SST)】

- A special tool for attaching and detaching the temperature sensors. (intake air temperature sensor and cylinder head temperature sensor)
- Attach this tool to 1/4"(6.3mm) Socket wrench handle. (Socket wrench handle is not included in this set)

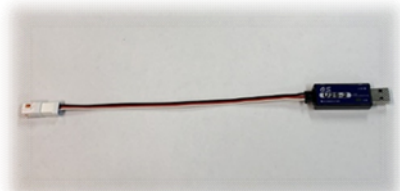

【Serial signal converter】 Model : U2S-2

- To be used to convert UART serial signal from ECU to USB serial signal when ECU is connected to a computer.

Standard screw tightening torque

■ Cap screw (Hex socket head bolts)

screw size	N·m
M2.6	1.1
M3.0	1.5
M4.0	3.6
M5.0	7.2

*However, some tightening points have specific torque instructions. The bolts with specific torque instructions are shown in the exploded view's parts list.

Standoff mount

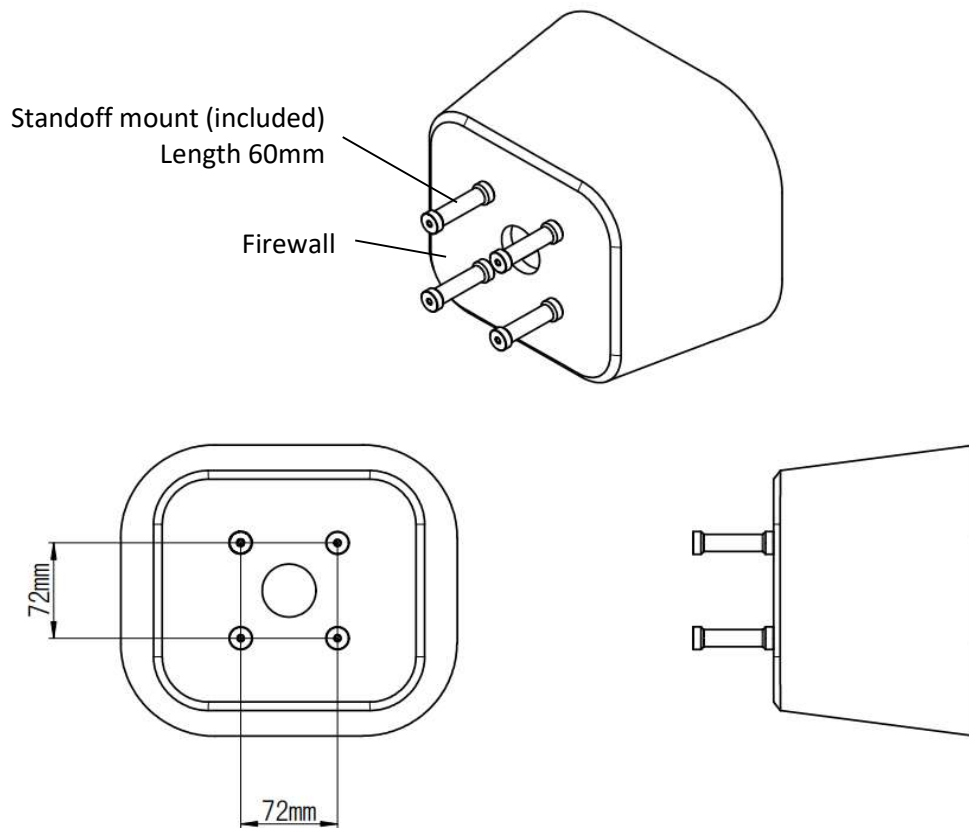

- Install the standoff engine mounts that come standard with the engine at a position of 72 mm x 72 mm.
- The length of the standard standoff engine mount is 60 mm.

Installation

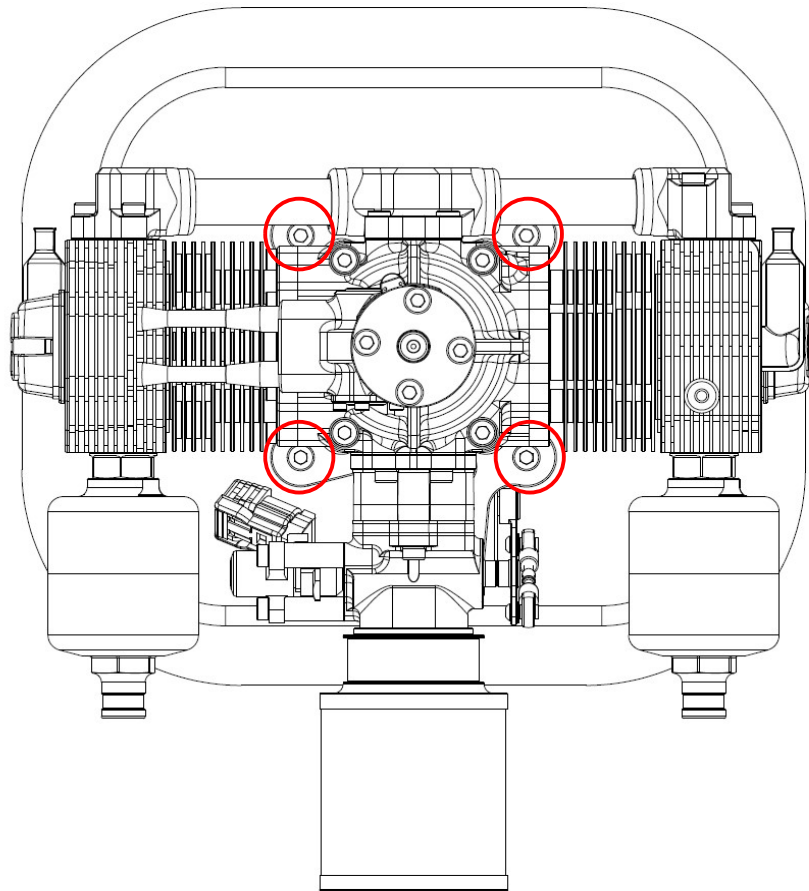

- Use M5 20mm length allen bolts to secure the engine to stand off engine mount.
- Please used Nord-Lock Washer to tighten 4 bolts.

(Nord-Lock Washer)

There is direction for stacking Nord-Lock washers.

As shown in the photo below, stack them so that the large wedge sides face each other.

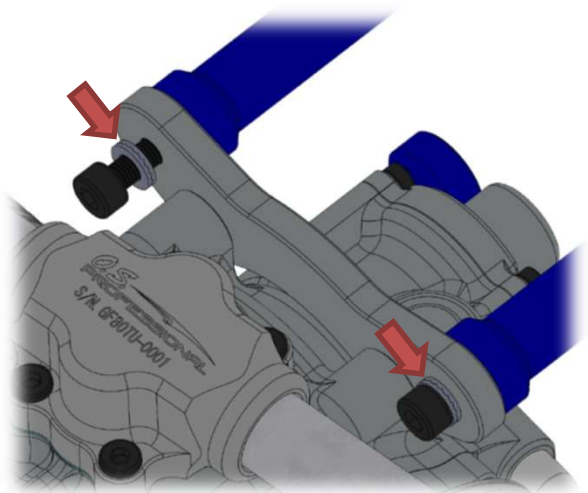

Fuel delivery

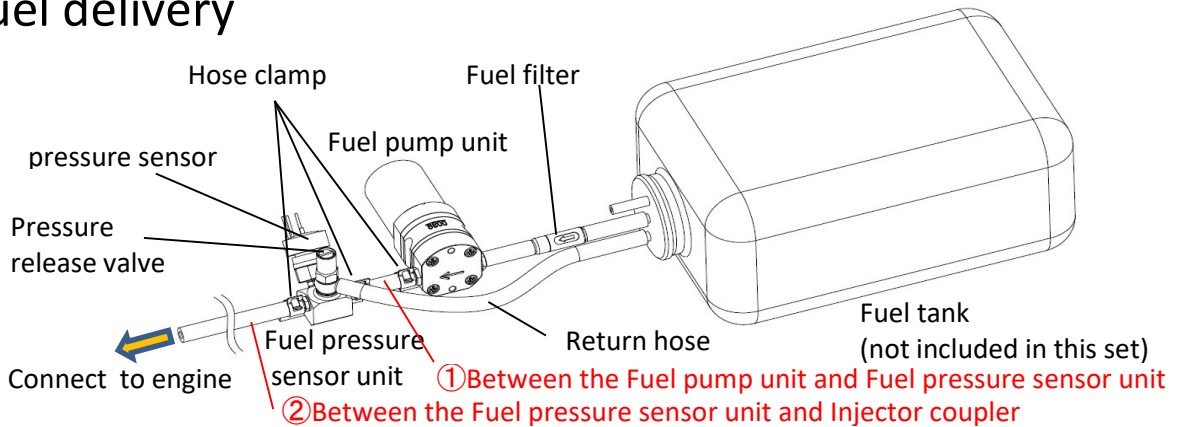

- Connect the Fuel pump unit and the Fuel pressure sensor unit close to the Fuel tank.
- Use a Fuel filter between Fuel tank and Fuel pump unit.
- Fuel pump unit creates 300kPa pressure. Apply a hose clamp to each hose joint.
- Be sure to use the attached high-pressure fuel hose for the parts where high pressure is applied ① and ②.
- Connect the pressure release valve nipple to the fuel tank with a return hose.

Fuel tank

【Example piping】

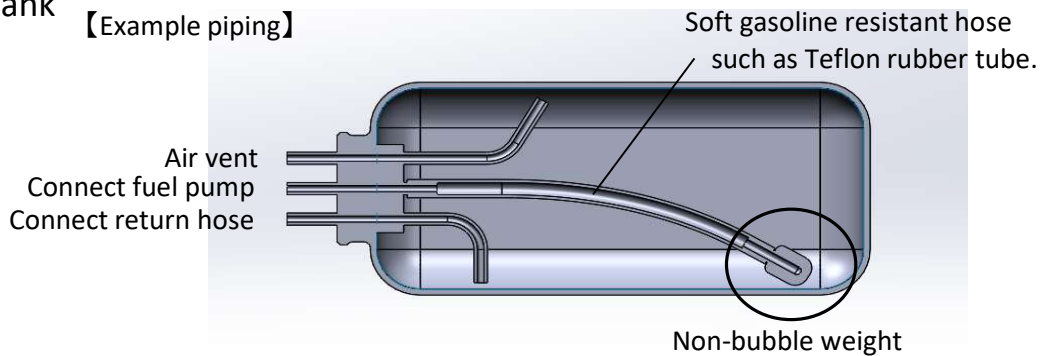

- Use a Non-bubbleweight in the tank to avoid creating air bubbles in the fuel supply tube. Air bubbles may cause engine misfire and stalling.
- Connect the tubes in the fuel tank firmly to the pipes in a fashion in which they will not easily come off. Use clamps or wire ties if necessary.

Fuel pump

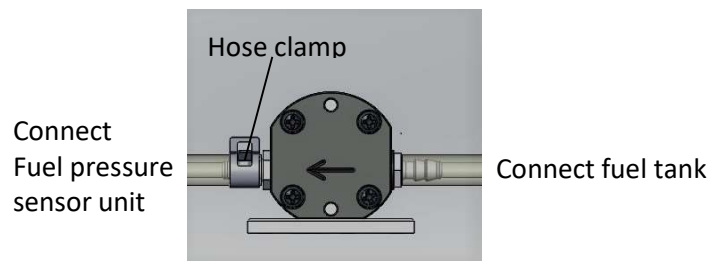

- The arrow mark shows the direction of fuel flow.
- Apply a hose clamp to the pressurized side of the hose.

CAUTION :

- A one-way valve is built in the fuel pump so pressure remains in the fuel line even after stopping the pump. Open the Pressure release valve to remove residual pressure.

Fuel pressure sensor unit

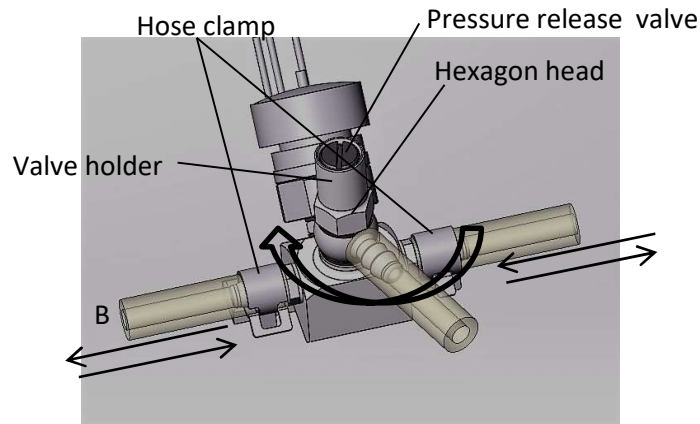

- The Pressure sensor works both from A to B and B to A. Decide the mounting direction according to your fuselage layout. Apply Hose clamps to both sides of the Pressure sensor.
- To change the direction of Pressure release valve nipple, loosen the Hexagon head with an 8mm wrench. Tighten the Hexagon head again after deciding the direction.
- If there are air bubbles in the tube between the fuel tank and the fuel pressure sensor unit after filling up the fuel tank, when the ECU switch is turned on for the first time, open the valve until the screw top becomes flush with edge of the valve holder as shown below. After eliminating the air bubbles, close the valve. Do not open the valve more than the flush position to avoid the pressurized fuel from coming out of the valve.
- Air bubbles between the Fuel pressure sensor unit and the engine (Injector) are of no concern as they do no harm since they are discharged through the Injector.

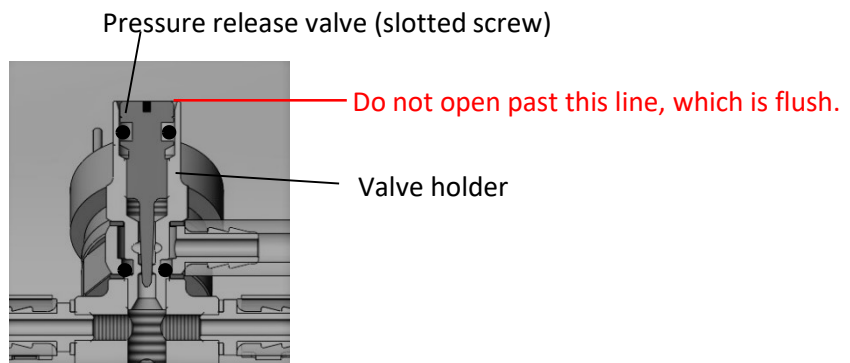

- Release the residual pressure in the fuel system after a days use to avoid fuel expanding the fuel joints and causing leaks.

Installation

Be sure to use a high pressure fuel hose.

From fuel pressure sensor unit →

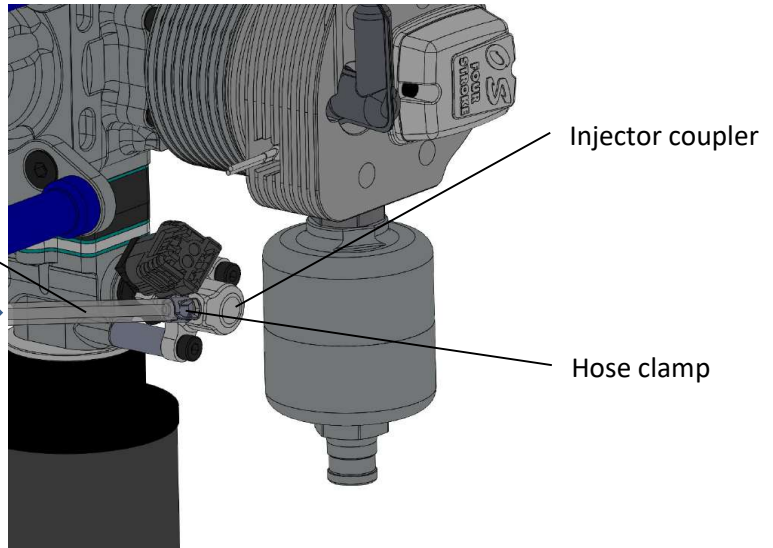

• Connect the tube from the Fuel pressure sensor unit to the Injector joint nipple. Use a Hose clamp. It is a must.

• Once a tube is connected to a nipple, an end of the tube is expanded and deformed. Cut the end when you use the same tube again.

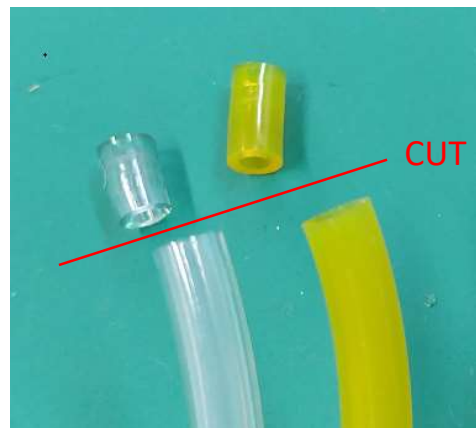

• Cut off an end of the tube when it is difficult to pull out from a nipple. Do not pull and twist the tube strongly to pull it out. Do not damage to a nipple when you use a nipper or a knife to cut the end of the tube.

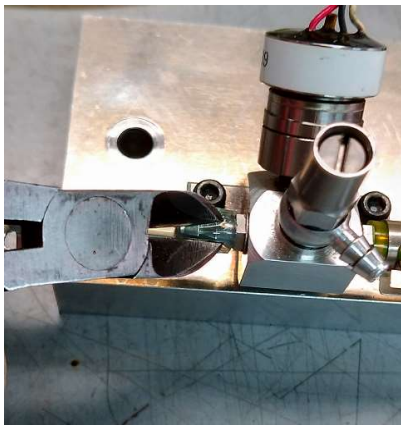

Silencer

F-6050 Silencer structure

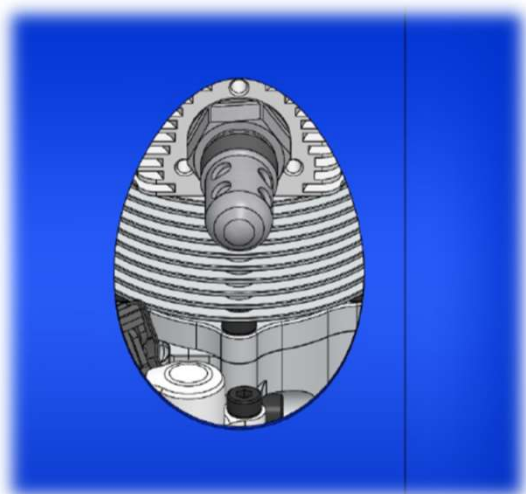
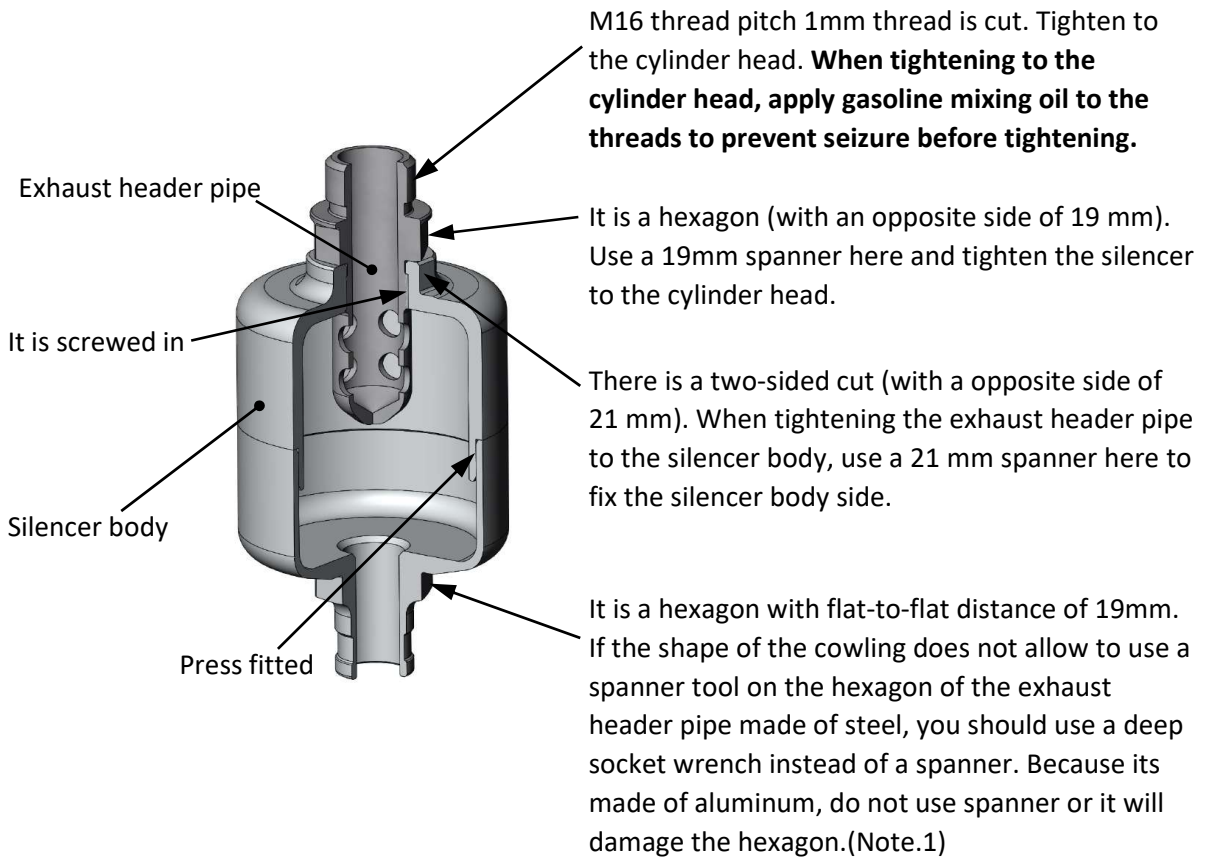

If the exhaust header pipe remains on the cylinder head side when you try to remove the silencer by hooking a tool on the silencer body, you can remove the exhaust header pipe using a 19 mm deep socket wrench.

On the contrary, when installing, the exhaust header pipe can be attached to the cylinder head first, and then the silencer body can be attached. (Note.1)

Note.1

This method is an exceptional usage in situations where a tool cannot be inserted. Basically, hang a tool on the hexagon of 19 mm on the opposite side of the exhaust header pipe to attach or detach the silencer. Also, please design the aircraft so that it can be done.

Propeller

- Use a wooden or carbon fiber propeller. Do not use nylon propellers as they may lack strength.
- Do not use a propeller that is slightly scratched or has a large impact even if it is not scratched.
- The size and shape of the propeller will be selected as the best one after actually flying, but first select it by referring to the following range.

23x8-12 , 24x8-12 , 25x8-10 (diameter x pitch Inch)

- It is recommended to use a spinner. You can use the included aluminum spinner or a commercially available metal or resin spinner, but use a well-balanced and strong spinner.
- Imbalance of the propeller or spinner may cause vibration and damage the propeller or the aircraft. Be sure to use a well-balanced and strong enough propeller and spinner.
- Be sure to tighten the propeller mounting bolts via the propeller washers when mounting the propeller. Propeller mounting bolts are included, but if you use a propeller with a thin hub and the screws bottom out, or if you use a propeller with a thick hub and cannot screw it into the drive spacer sufficiently, refer to the table below to select the right bolts. Please replace them with certain steel hexagon socket head cap bolts.

Propeller hub thickness	Bolts
14~20mm	M5x35mm
18~24mm	M5x40mm (included)
22~30mm	M5x45mm

- Install the propeller day of the first flight and remove it after the last flight.
- Check the appearance of the propeller mounting bolts every time, and replace them if they are scratched or rusted. Even if there is no abnormality in the appearance, replace them regularly (about 50 flights).

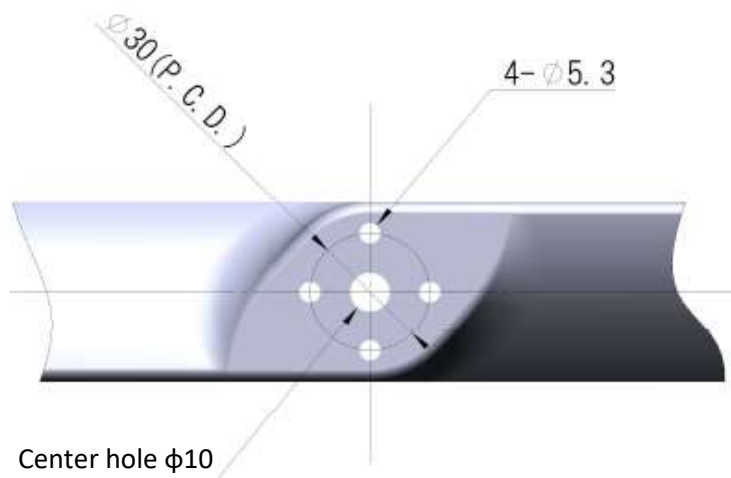

Propeller mounting hole dimensions

Plug cap

- Insert the plug cap as shown in Photo.1 by aligning it with the recess of the cylinder head. There are two plug cords from the igniter, but there is no distinction between the left and right cylinders.

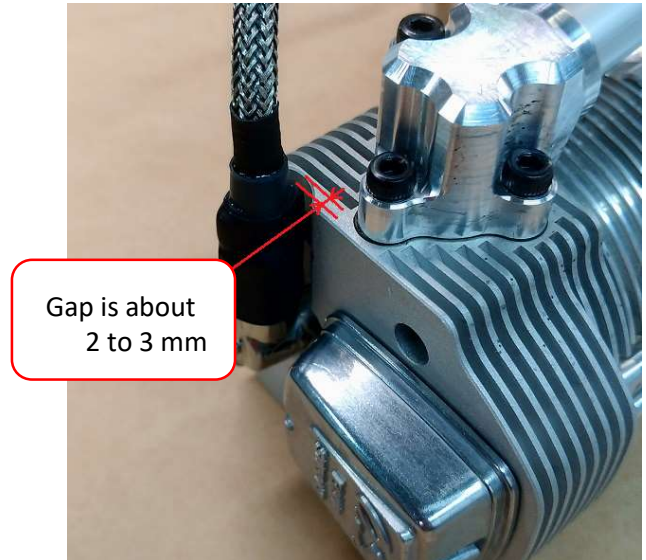

- To remove the plug cap, attach a commercially available nylon cable tie (repeat type with unlock) to the plug cap as shown in Photo.2, put your finger on it, and pull it while turning it toward the slope side of the recess of the cylinder head to remove it. (See Photo.3). If you remove the plug cap by hand, be sure to wear gloves to protect your hands. Immediately after the engine is stopped, the plug cap is also hot, so cool it down before proceeding.

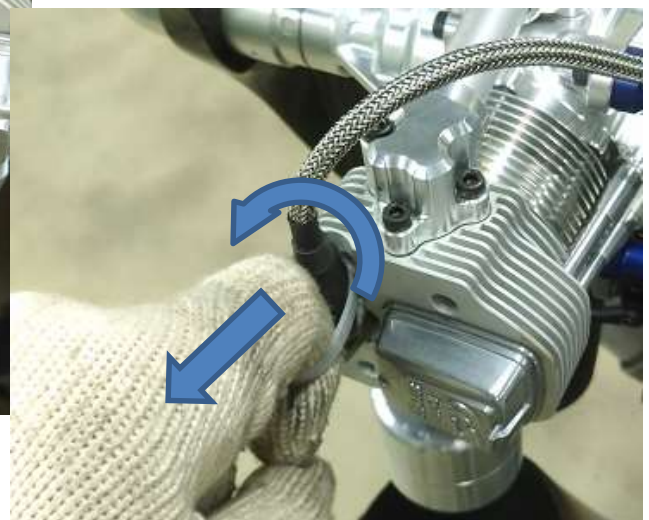
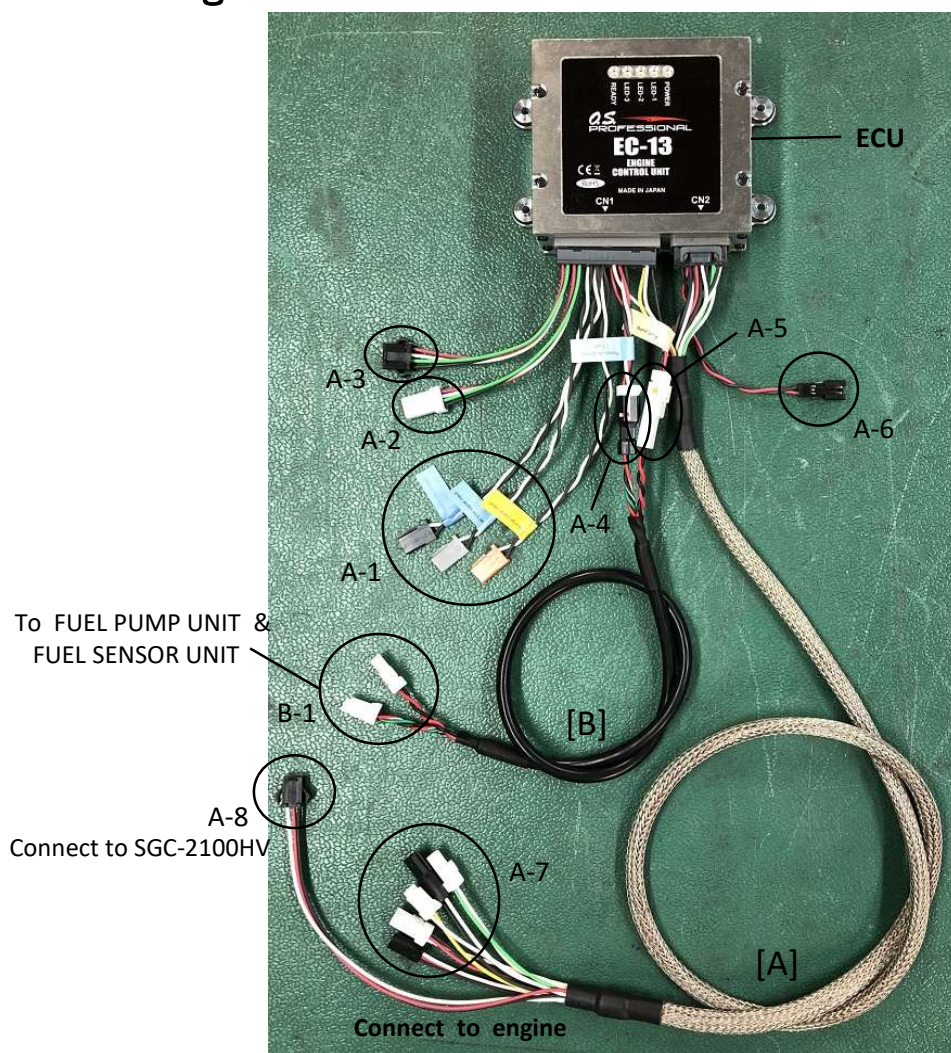

Photo.3

ECU Wiring harness









[A] EC-13 Wiring harness

- A-1
 - Throttle signal input (PWM VIH=2.6V, VIL=0.4V, MAX5.5V)
 - Fuel trim signal input (PWM VIH=2.6V, VIL=0.4V, MAX5.5V)
 - Starter start signal input(PWM VIH=2.6V, VIL=0.4V, MAX5.5V)
- A-2
 - Serial communication (UART, TTL logic level is 3.3V)
- A-3
 - CAN communication
- A-4
 - Fuel pressure sensor
- A-5
 - Fuel pump
- A-6
 - Power supply (DC10V~18V, MAX 1.5A)
- A-7
 - Cylinder head temperature sensor
 - Injector
 - Throttle servo
 - Ignition signal
 - Crankshaft rotation sensor
- A-8
 - SGC signal output

[B] pump connection cord (extendable)

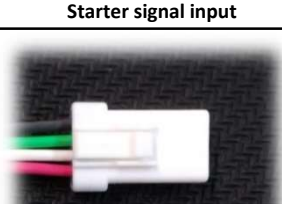
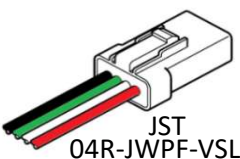
- B-1
 - fuel pressure sensor
 - fuel pump unit

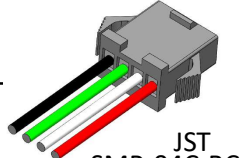
Engine control unit (ECU)

[A]	A-1	 Throttle signal input	<ul style="list-style-type: none"> Connect to a receiver or throttle signal cable from flight controller. <p>Specification PWM signal (*1) Set the travel width so that the PWM signal width is 1100 μs or less on the throttle closed side and the PWM signal width is 1940 μs or more on the throttle opening side. [W: Signal / B: GND] VIH=2.6V, VIL=0.4V, MAX5.5V</p>
	A-1	 Fuel trim signal input	<ul style="list-style-type: none"> If it is necessary to fuel adjustment from external device, connect it to the fuel adjustment signal from the receiver or flight controller. ECU controls quantity of fuel injection normally, so correction signal from the outside is not necessary. Leave it unconnected or connect 1520μs (neutral) PWM signal. When pulling out during operation, it holds the state just before. <p>Specification PWM signal: 1520μs (neutral) ±420μs (*1) PWM + → increase fuel supply The range of increase and decrease is ±30%. [W: Signal / B: GND] VIH=2.6V, VIL=0.4V, MAX5.5V</p>
	A-1	 Starter signal input	<ul style="list-style-type: none"> Input the PWM signal from the external device such as transmitter, flight controller etc. to start the starter motor. The starter goes into standby mode when the PWM signal is 1000 μs to 1400 μs. The PWM signal drives the starter at 1600 μs to 2000 μs. When ECU is started, if PWM signal is 1600μs or more, it will sound the alarm and stop functioning to prevent malfunction. <p>Specification PWM signal: 1000μs~2000μs (*1) [W: Signal / B: GND] VIH=2.6V, VIL=0.4V, MAX5.5V</p>
	A-2	 Serial communication	<ul style="list-style-type: none"> the connector for serial communication To be used to monitor parameters or to connect to a computer for initial setting. <p>Specification UART(TTL logic level is 3.3V.) [R: DC+5V / W: TX / G: RX / B: GND]</p> <div style="text-align: right;">  JST 04R-JWPF-VSLE-S </div>
	A-3	 CAN communication	<ul style="list-style-type: none"> the connector for CAN communication <p>Specification CAN [R: DC+5V / W: Signal(High) / G: Signal(Low) / B: GND]</p> <div style="text-align: right;">  JST SMP-04C-BC </div>
	A-4	 Fuel pressure sensor	<ul style="list-style-type: none"> Connect to Fuel pressure sensor via Pump connection cord. <p>Specification Pressure sensor [R: DC+5V / W: Signal / B: GND]</p>

*1. The period of the PWM signal input to EC-21 should be 10 to 20 ms (50 to 100 Hz).

Wiring color

R	Red	G	Green
W	White	Y	Yellow
B	Black		

Engine control unit (ECU)





[A]	A-5	 Fuel pump	<ul style="list-style-type: none"> • Connect to Fuel pump via Pump connection cord. <p>Specification</p> <p>[R: DC+12V / B: GND]</p>
	A-6	 Power supply	<ul style="list-style-type: none"> • Supply power. <p>Specification DC10V~18V (MAX 2A)</p> <p>[R: Power supply / B: GND]</p>
	A-7	 Cylinder head temperature sensor	<ul style="list-style-type: none"> • Connect to the temperature sensor of the cylinder head. <p>Specification PT100 Platinum resistance thermometer</p> <p>[Y: No polarity / W: No polarity]</p>
	A-7	 Injector	<ul style="list-style-type: none"> • Connect to Injector harness. <p>Specification</p> <p>[W: DC+12V / G: GND (open-drain)]</p>
	A-7	 Throttle servo	<ul style="list-style-type: none"> • Connect to Throttle servo. <p>Specification PWM signal</p> <p>W: Signal / R: DC+5V / B: GND]</p>
	A-7	 Ignition signal	<ul style="list-style-type: none"> • Connect to the rotation signal input cable of Igniter. <p>Specification</p> <p>[W: Signal / B: GND]</p>

Wiring color

R	Red
W	White
B	Black

G	Green
Y	Yellow

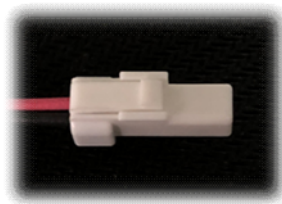
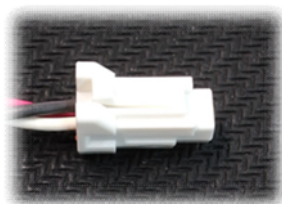
Engine control unit (ECU)

[A]		
A-7	 <p>Crankshaft rotation sensor</p>	<p>• Connect to Crankshaft rotation sensor.</p> <p>Specification Hall-effect switch.</p> <p>[W: Signal / R: DC+5V / B: GND]</p>
A-8	 <p>SGC</p>	<p>• Connect to SGC-2100HV.</p> <p>Specification PWM signal</p> <p>[W: Signal / R: DC+5V / B: GND]</p>
[B]		
B-1	 <p>Fuel pump</p>	<p>• Connect to Fuel pump.</p> <p>Specification (Extension cord)</p> <p>[R: DC+12V / B: GND]</p>
B-1	 <p>Fuel pressure sensor</p>	<p>• Connect to Fuel pressure sensor.</p> <p>Specification (Extension cord)</p> <p>[R: DC+5V / W: Signal / B: GND]</p>
(A-4)	 <p>Fuel pressure sensor</p>	<p>Connect to (A-4).</p> <p>Specification (Extension cord)</p> <p>[R: DC+5V / W: Signal / B: GND]</p>
(A-5)	 <p>Fuel pump</p>	<p>• Connect to (A-5).</p> <p>Specification (Extension cord)</p> <p>[R: DC+12V / B: GND]</p>

Wiring color

R	Red
W	White
B	Black

G	Green
Y	Yellow

PREPARATION (EC13-LINK)

NOTE:

- Using EC13-LINK, you can monitor the parameter data in real time and change the parameters. After overhauling the engine, after disconnecting the throttle linkage, reset the throttle position using the EC13-LINK.

【Equipment you need】

- PC with Windows® (10/11) and USB port. The included U2S-2 (serial signal converter) uses an FTDI chip, the driver is registered in Windows® Update. Therefore, in internet environment, the driver is automatically downloaded and installed by connecting the USB serial converter to the PC. Install the driver in advance in an internet environment.

【Installation of the software】

- Copy the EC13-LINK_XXXX.exe(XXXX:Version number) file to any file in the PC, then execute the file.
- When you intend to delete the software, just delete the EC13-LINK_XXXX.exe file.

【Connecting】

- Connect the 4-pin connector of U2S-2 to the ECU's serial communication connector (A-2).
- Connect the U2S-2 main unit to the USB port of the PC.

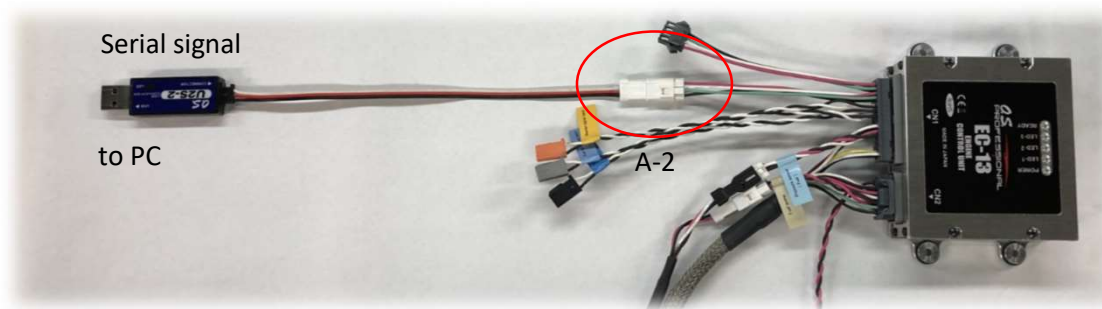

- Connect the ECU to the engine.
- EC13-LINK can be activated without connecting any sensors to the ECU. For example, in teaching of throttle positions, you can activate the throttle servo as long as it is connected to the ECU.

OPERATION (EC13-LINK)

CAUTION :

- Do not turn on the ECU when the fuel tank is empty. Operating the pump without fuel may damage the pump.
- In case you need to turn on the ECU without fuel supply, for example, to rewrite the settings by EC13-LINK, to deactivate the pump, disconnect the connector on the pump. Thirty seconds after disconnecting the connector, the buzzer rings alarming abnormality of fuel pressure, but you can stop it by clicking "BUZZ OFF" button in EC11-LINK display.

《connecting to EC13-LINK》

【1】 Connecting the ECU to the engine

- Check the connectors of both the ECU and the engine.

【2】 Connecting the ECU to the PC

- Check the connection of the ECU and the PC.

【3】 Turning of the ECU

- Turn on the ECU.

【4】 Starting up the software

- Execute the file EC11-LINK_xxxx.exe, which you copied to the PC. The following window will open.

The screenshot displays the EC13-LINK software interface. At the top left, there is a dropdown menu for 'COM1' and a 'MONITOR' button. The main area is divided into several sections:

- Control Buttons:** 'Open', 'Close', 'READ', 'Exit', 'Save Settings', 'Initialize Settings', and 'MONITOR'.
- Throttle Settings:** 'Throttle fully closed position [us]', 'Throttle idle position [us]', 'Throttle fully open position [us]', and 'Throttle start position [%]' with corresponding input fields and buttons: 'Th_CLOSE', 'Th_RETURN', 'Th_IDLE', 'Th_OPEN', 'Th_START'.
- Engine Parameters:** 'Idle Speed', 'End of Starting Mode [Revolutions]', 'FUEL STARTUP', and 'Trim center position[us]' with input fields and buttons: 'IDLE SPEED', 'STARTING MODE', 'FUJEL STARTUP', 'TRIM'.
- Head Temperature Compensation:** A section with a 'Head Temp' button and a grid of input fields.
- Altitude Correction:** A section with an 'Altitude Correction' button and a grid of input fields.

At the bottom left, there is a status bar showing the hexadecimal value '00000 0000 0000 0000 00000000'.

【5】 Confirmation of COM port assignment

- Check which COM port the serial connection to the ECU is assigned using Windows® device manager. Refer to the operation manual of the Windows®.
- In case the serial connection is assigned to other than COM1 ~ COM20, assign it manually to one of them. Refer to the operation manual of the Windows® how to assign a COM port number.

【6】 Setting of a COM port number

- Select the same COM port you have assigned from the pull down menu. Then click [OPEN] and the connection is completed.

Select the same COM port number as you have confirmed by Device manager.

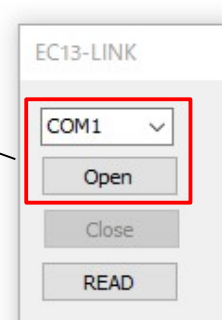

[Close] button

- For disconnecting a COM port connection. Do not click until you have finished using EC13-LINK.

[READ] button

- For reading the current setting value in the ECU

NOTE:

The setting values are stored in the flash memory in the ECU, and are read out in the memory when the ECU is turned on. When you change the setting values via EC13-LINK, the new values are memorized in the memories at first, then by clicking [Save Settings] button, the new values are memorized the teh flash memories.

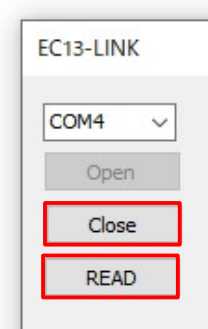

[Exit] button

- For exiting EC13-LINK

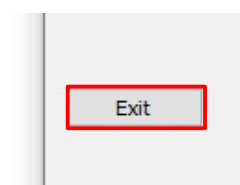

OPERATION (EC13-LINK)

【ERROR MESSAGE】

•The following are error messages and what they mean.

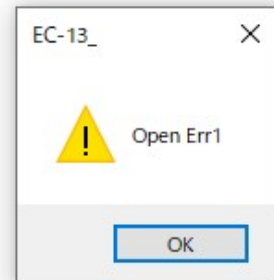

Open Err1	<ul style="list-style-type: none"> ① The serial port does not open. ② Check if the COM number of the serial port is correct. ③ Check the connection between the ECU and the PC.
RES TO	<ul style="list-style-type: none"> ① Response signals from EC-13 are not received. ② Check if the ECU is turned on and electric power is properly supplied. ③ Check the connection between the ECU and the PC.
Now Open	<ul style="list-style-type: none"> ① The serial port is open. ② Click [OK] button and continue the operation.
Open Err2	<ul style="list-style-type: none"> ① It failed to acquire the serial port settings from the PC. ② Check the connection between the ECU and the PC.
Open Err3	<ul style="list-style-type: none"> ① It failed the serial port setting in the PC. ② Check the connection between the ECU and the PC.
Open Err10	<ul style="list-style-type: none"> ① The serial port is still closed. Open the serial port.
RES SUM ERR	<ul style="list-style-type: none"> ① There is an error in the received data from the ECU. ② Check the connection between the ECU and the PC.

《setting of the each value》

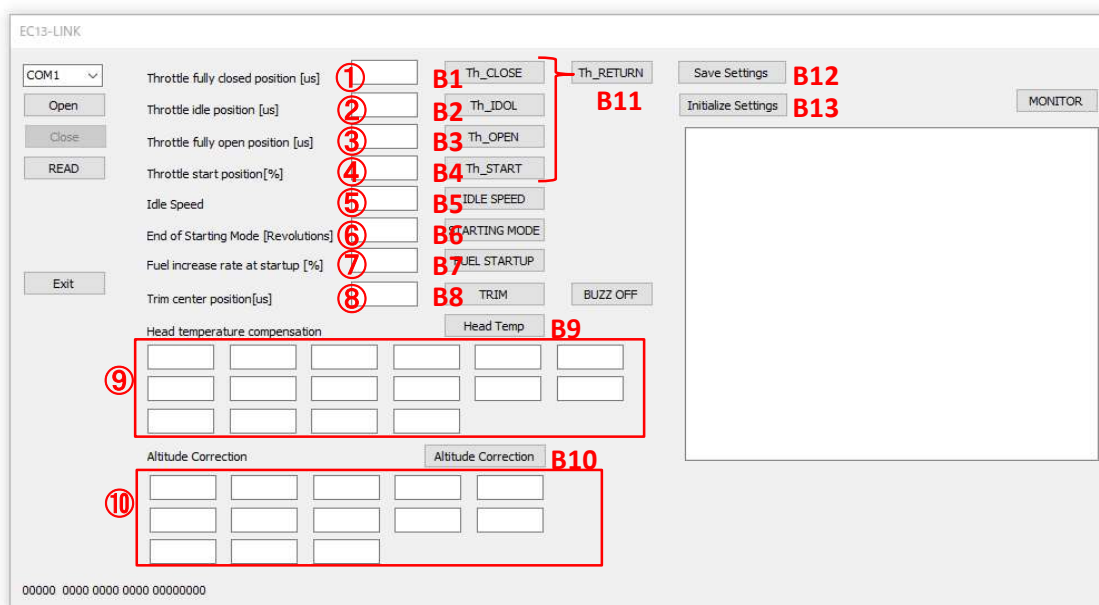

Input parameters in the edit boxes shown above (①~⑩), and click each button corresponding to each number (B1 – B10) to transfer the data to the ECU memory. For example, input value in edit box ① and click B1 button to transfer the input value to the ECU memory. ①~④ are for throttle servo settings. **After inputting values in ①~④ and clicking B1 – B4, the throttle servo moves according to the input values. Please be careful about pinching such as fingers.** To return the operation of the throttle servo normal (control by throttle signals), click [Th_RETURN] button (B11). After setting all the above parameters, you must always click [Save Settings] button (B12) to write the input data in the ECU memory into the flash memory. Turning off the ECU without doing so causes loss of all the input parameters. You can initialize the settings by clicking [Initialize Setting] button (B13) to return to the default settings, but when you initialize the settings, you need to set “Teaching processes” of throttle position again (setting items ①~④ below).

[Setting Items]

①Throttle fully closed position [μs]

• Setting of the full close position by pulse width of PWM signal.

- The mark on the throttle valve aligns with the mark at full close position usually around 1150μs. Change the parameter to align each mark as shown on the left.
- Inputting extremely small value may cause damage to the throttle servo creating excessive tension on the throttle linkage. So change the parameter ±10μs or less at each adjustment.

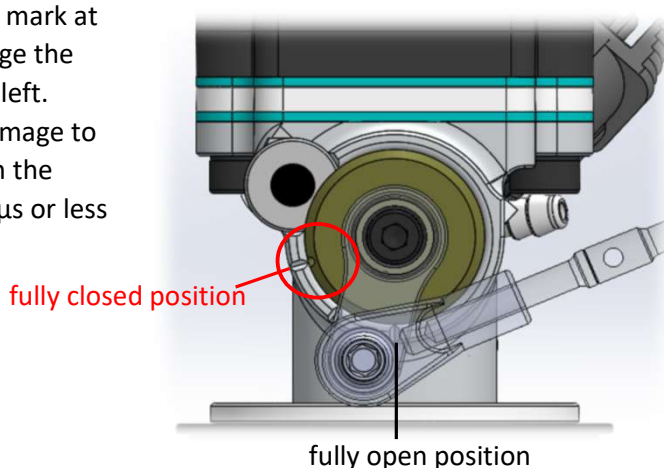

②Throttle idle position [us]

•Setting of the idling position by pulse width of PWM signal. The position of the throttle valve is usually +50us(+40us~+60us) from the fully close position.

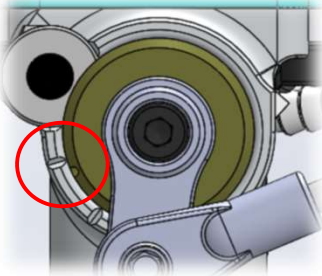

•This position, slightly open from the full close position is the reference position. The throttle valve is automatically controlled by the ECU to hold the idling rpm you have set when the throttle valve position is at idling position, in case you use a transmitter, the throttle stick of the transmitter is moved down to the bottom.

•In case the ECU could not hold the idling rpm and the engine stalls, add +5us to the current parameter. When the aircraft is diving with the throttle control signal at the idling position, in case you use a transmitter, the throttle stick of the transmitter is moved down to the bottom, the propeller turns at higher rpm than the set rpm at idling by airflow to the propeller created by the dive. In this case, the ECU closes the throttle valve excessively until the engine stalls trying to reduce the propeller rpm. If it happens, add +5us to the parameter also.

•In case the idling rpm doesn't decrease to the value you set in the process ③, even if temperature of the engine goes over 100°C, reduce the value by -5us each time until the rpm decreases.

③Throttle fully open position [us]

•Setting of the full open position by pulse width of PWM signal.

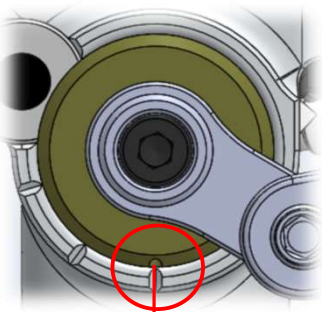

fully open position

•The mark on the throttle valve aligns with the mark at full open position usually around 1870us. Change the parameter to align each mark as shown on the left.

•Inputting extremely large value may cause damage to the throttle servo creating excessive tension on the throttle linkage. So change the parameter ±10us or less at each adjustment.

④Throttle start position[%]

•Setting of the throttle valve position when you start the engine. To start the engine easier, the ECU opens the throttle valve at this position even throttle signal from your flight controller ordered to close more, in case you use transmitter, you move down the throttle stick of the transmitter and close the throttle valve more than this position. Parameter is to be set 0%~100%representing fully close to fully open with 0%~100%. The parameter is usually 20%.

⑤ Idling speed[rpm]

• Setting of the idling rpm when the throttle stick of the transmitter is moved down to the bottom, or throttle signal from your flight controller ordered the throttle valve to stay at idling position. The parameter varies depending on your propeller choice and an aircraft. Although the rpm at idling depends on propeller, the parameter is usually between 1600 and 2400 rpm. In case you input the parameter beyond the range, the ECU controls the idling rpm between lower and upper limit. The ECU aim at the idling rpm you have set once the engine is warmed up. But the idling rpm is slightly higher than the set parameter when the engine is still cold.

⑥ End of starting mode[revolutions]

• Setting the timing to exit from “ENGINE STARTING MODE”. The counting starts when engine rpm exceeds 960rpm. To enter the normal operating mode, input the parameter to decide at how many revolutions after reaching the 960rpm to exit from “ENGINE STARTING MODE” on the ECU. The parameter is usually 50 revolutions.

⑦ Fuel increase rate at startup [%]

• Setting of extra fuel injection at engine start. The parameter shows how much percentage (%) of fuel is to be added to the basic fuel injection. Usually the parameter is 70%. If the parameter is 70%, 170% of the basic injection amount of fuel will be injected.

⑧ Trim center position[us]

Setting of the central parameter (neutral) of Fuel increase/decrease adjustment signal (PWM). Set the parameter according to a receiver or flight controller you use. The pulse width parameter input here is the neutral position. Fuel increases/decreases $\pm 30\%$ in the range of $\pm 420\mu s$. Positive (+) side increases fuel injection and negative (-) side decreases. The default setting is 1520 μs , which is the neutral position of Futaba receiver.

⑨ Head temperature compensation

• Increasing fuel injection according to the rise of Cylinder Head temperature (CHT). This is the function to stabilize engine operation at low temperature and prevent the engine from overheating at high temperature. The parameter can be input at 16 points, by 20°C interval between 0~300°C. The parameter shows how much extra fuel is added to the basic fuel injection by percentage (%). The temperature between the points is complemented by the lower and higher points. The parameter at 0°C is applied to below 0°C, and the one at 300°C is applied to more than 300°C. Use the default settings in an ordinary case.

• **It has up to 300°C of correction data but that does not mean it can be used up to 300°C. If the cylinder head temperature goes over 240°C at any moment, please take measures to allow the engine to get more air to cool down. The ideal temperature range is from 160°C to 220°C**

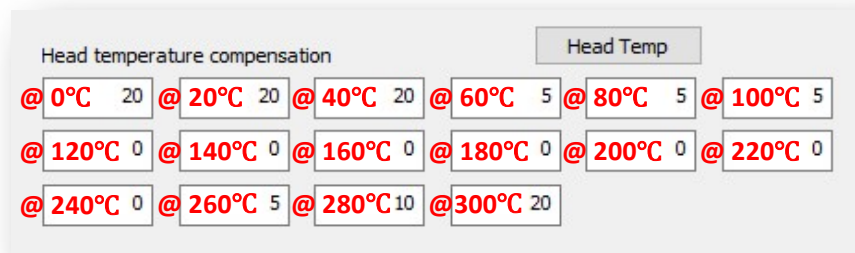

⑩ Altitude correction

• Increase/decrease fuel injection according to altitude. The parameter can be input at 13 points by 500m interval from -1000~5000m. The parameter shows how much extra fuel is added to the basic fuel injection by percentage (%). The altitude between the points is complemented by the lower and higher points. The parameter at -1000m is applied to below -1000m, and the one at 5000m is applied to more than 5000m. Use the default settings in an ordinary case.

• **It has between -1000m to 5000m of correction data but that does not mean it can be used in such high altitude range. The engine is designed to be used in the range between 0m to 3000m altitude.**

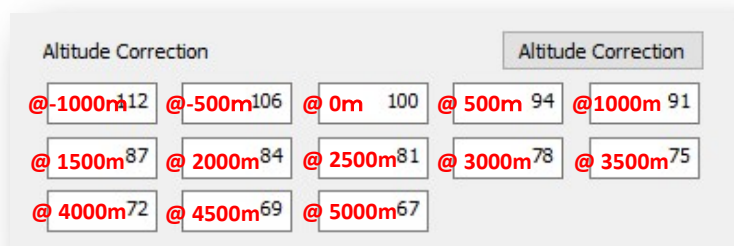

CAUTION:

- Make sure to click [Save Settings] button (B12) to write the input data in the ECU memory into the flash memory. Turning off the ECU without doing so causes loss of all the input parameters.
- Setting items ①~④ are the “Teaching processes” of throttle position.
- Do not change the parameters except for ①~⑤ unless it is needed. The engine performance might get worse.
- Settings of input side of throttle signal is adjusted using the following “MONITOR” function. Opening of throttle valve is affected by the setting of throttle servo position. Set throttle signal input after “Teaching processes” (①~④).

《MONITOR》

• Press [MONITOR] button with the ECU connected to the PC, and you can monitor the updated information in the ECU. To exit the MONITOR mode, click [Mon Stop] button.
([MONITOR] button is switched to [Mon Stop] during the MONITOR mode).

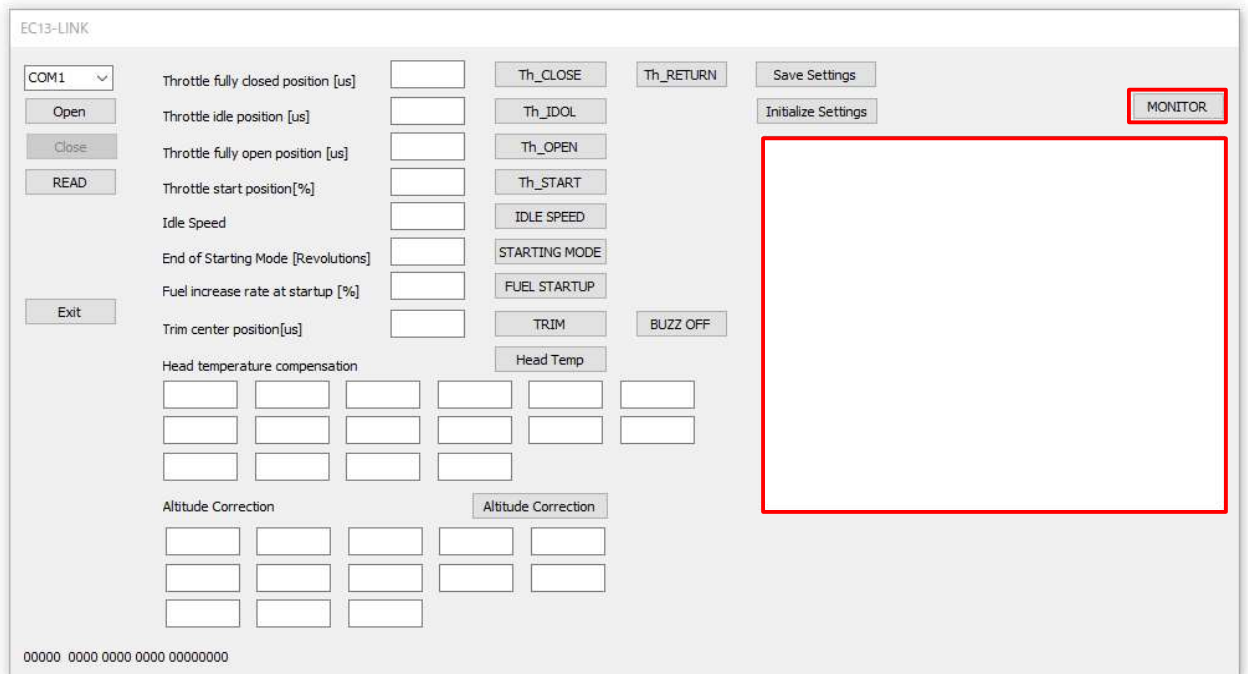
**【Information shown during the MONITOR mode】****(1) Pressure (hPa)**

Atmospheric pressure measured by the sensor in the ECU.

(2) Fuel pressure (kPa)

Fuel pressure after the fuel pump.

(3) 3.3V voltage (mV)

Voltage of the 3.3V power supply line of the ECU.

(4) 5V voltage (mV)

Voltage of 5v power source line in the ECU.

(5) 12V voltage (mV)

Voltage of the 12V power supply line of the ECU.

(6) Head temperature (°C)

Temperature measured by the temp. sensor in the cylinder heads.

OPERATION (EC13-LINK)

(7) Throttle signal input (%)

Throttle position (0 - 100%) controlled by throttle signals from a RC receiver or a flight controller.

NOTE:

- throttle positions are affected by the settings of the throttle servo. After teaching of the throttle positions, adjust the travel amount (end point) of throttle signal input from the receiver or the flight controller referring to the value on the monitor.
- The end points of throttle fully open and fully closed positions are to be set 0% and 100%, or -1% and 101% with some tolerance. (signals 0% or less and 100% or more are recognized as 0% and 100% respectively.)

(8) Throttle signal output (%)

The signal output to the throttle servo; how much throttle is open, is shown as 0% through 100%.

(9) Trim signal Width (μ s)

Input value (the width of PWM signal) of the fuel adjustment correction from a receiver or a flight controller.

(10) Rotation speed (rpm)

Revolutions of the engine per minute.

Pressure	1007 hPa
Fuel pressure	300 kPa
3.3V voltage	3270 mV
5V voltage	5000 mV
12V voltage	12040 mV
Head temperature	20 °C
Throttle signal input	0 %
Throttle signal output	20 %
Trim signal Width	1520 us
Rotation speed	0 rpm
*	

(Display example)

【Starter generator motor (SGM)】

System configuration

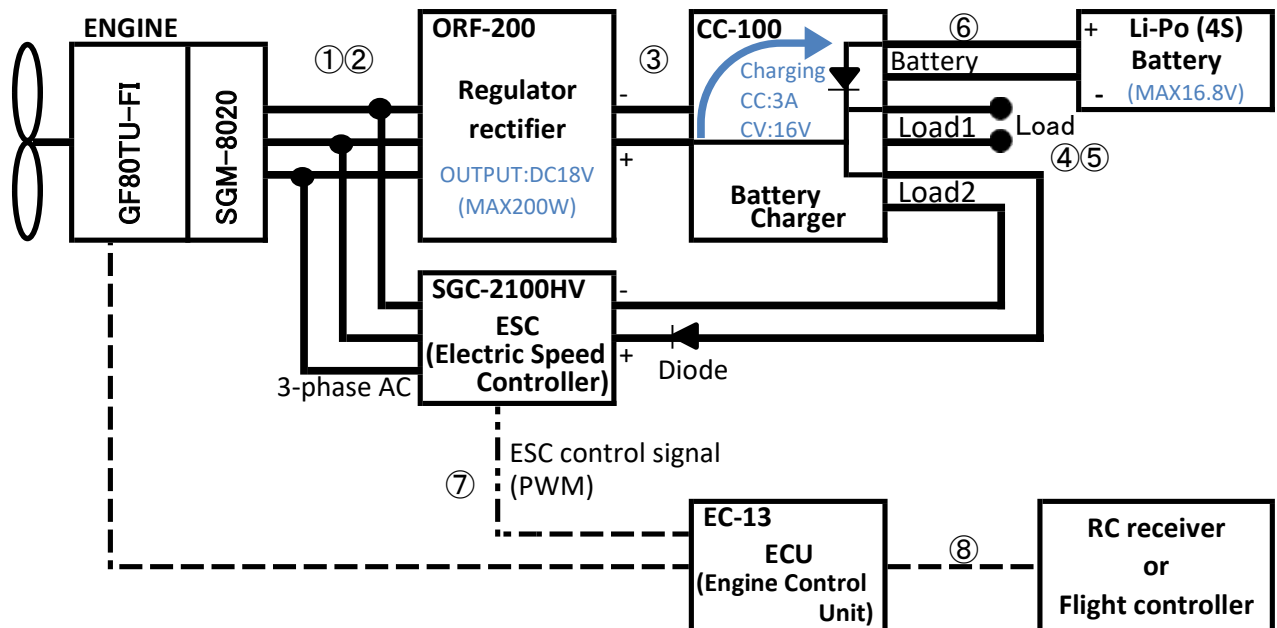





- A maximum of 200W can be generated by the Starter Generator Motor (hereafter SGM) located on the engine crank shaft.
- SGM also has the ability as a starter motor when starting the engine.
- Regulator rectifier ORF-200 and ESC SGC-2100HV are connected in parallel to SGM.
- ORF-200 is an open type regulator rectifier with a maximum of 200W (10 minutes) / continuous 120W.
- The SGC-2100HV is an ESC with a withstand voltage of 90V and drives the SGM when the engine is started.
- CC-100 is a charger dedicated to 4S Li-Po batteries, which charges the battery with the power output from the ORF-200 at 18V DC, and outputs power to the two load connection connectors. When the load is larger than the generated power, the battery powers the load.
- The CC-100 battery charging current is set to a maximum of 3A and the charging voltage is set to a maximum of 16V.
- Use a 4S Li-Po battery with a capacity of 3000mAh to 4000mAh and a C rate of 50C or more.
- Load1 and Load2, which are the load connection connectors of CC-100, have the same specifications. One is used by SGC-2100HV. Please connect the device used for the other side. The maximum usable capacity is 200W (10 minutes) / continuous 120W.

CAUTION:

- CC-100 does not have a balanced charging function. Please use the battery after fully charging it with a balance charger before flight.
- If the battery voltage drops below 15.5V, it may not be possible to crank the engine.
- Please note that 18V of the output voltage of ORF-200 is output as it is for both Load1 and Load2 of the load connection connector while the engine is running (power generation). If the system is configured assuming the maximum voltage of 4cell Li-Po battery is 16.8V, use a regulator etc. if necessary.
- For safety, be sure to supply the igniter power from the load connection connector via an isolated regulator.
- The battery connection connector outputs the appropriate voltage and current for battery charging by the charge monitoring circuit. Never connect anything other than a 4S Li-Po battery to the battery connector. If it is connected, the battery cannot be charged properly and it is dangerous.

Starter generator motor (SGM)

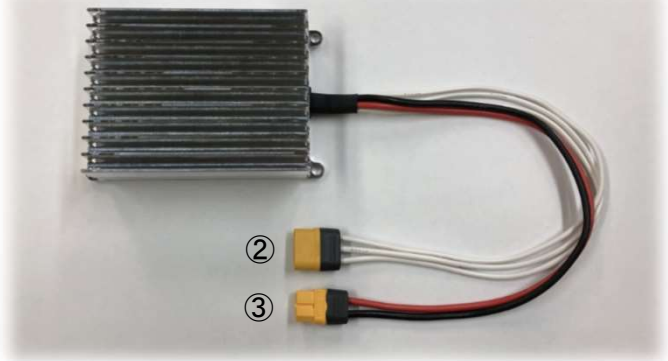
Connection

SGM-8020		
	 SGM-8020	• Connect to the MR60 (M) connector of the SGC-2100HV. Specification connector : MR60(F) • 3-phase AC
ORF-200		
	 OFR-200	• Connect to the MR60 (F) connector of the SGC-2100HV. Specification connector : MR60(M) • 3-phase AC
	 ORF-200	• Connect to XT60 (M) which is input side of CC-100. Specification connector : XT60(F) • DC18V

Starter generator motor (SGM)

Connection

SGC-2100HV	<p>①</p> <p>SGC-2100HV</p>	<p>• Connect to the MR60 (M) connector of the ORF-200.</p> <p>Specification connector: MR60(F) • 3-phase AC</p>
	<p>②</p> <p>SGC-2100HV</p>	<p>• Connect to the MR60 (F) connector of the SGM-8020.</p> <p>Specification connector: MR60(M) • 3-phase AC</p>
	<p>④ or ⑤</p> <p>SGC-2100HV</p>	<p>• Connect to the XT60 (F) connector of Load1 or Load2 of the CC-100.</p> <p>Specification connector: XT60(M) • DC15.5V~18V</p>
	<p>⑦</p> <p>SGC-2100HV</p>	<p>• Connect to the JST SM 3P (F) connector of ECU harness.</p> <p>Specification connector: JST SM 3P(M) • PWM</p> <p>[W: Signal / R: DC+5V / B: GND]</p>

Starter generator motor (SGM)

Connection

CC-100	<p>③</p> <p>CC-100</p>	<ul style="list-style-type: none"> • Power input of CC-100. • Connect to the output connector XT60 (F) of the ORF-200. <p>Specification connector : XT60(M)</p> <ul style="list-style-type: none"> • DC18V
	<p>④</p> <p>CC-100</p>	<ul style="list-style-type: none"> • Load1 load connection connector. • Load 1 and Load 2 of the load connector have the same specifications. <p>Specification connector : TX60(F)</p> <ul style="list-style-type: none"> • DC18V during power generation, battery voltage otherwise.
	<p>⑤</p> <p>CC-100</p>	<ul style="list-style-type: none"> • Load 2 load connection connector. • Load 1 and Load 2 of the load connector have the same specifications. <p>Specification connector : TX60(F)</p> <ul style="list-style-type: none"> • DC18V during power generation, battery voltage otherwise.
	<p>⑥</p> <p>CC-100</p>	<ul style="list-style-type: none"> • Connect a 4S Li-Po battery (capacity 3000mAh-4000mAh). • Use a battery with a C rate of 50C or higher. <p>Specification connector : XT60(M)</p> <ul style="list-style-type: none"> • DC15.5V~18V

Starter generator motor (SGM)

Connection

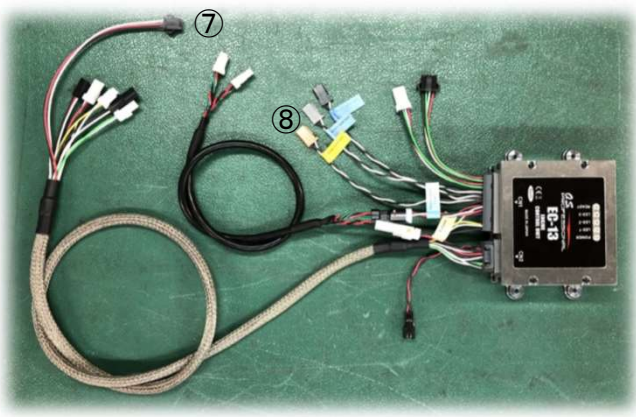
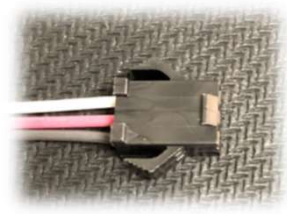
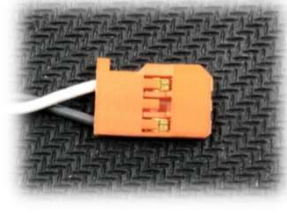
		
EC-13 ⑦		• Connect to SGC-2100 ⑦ connector.
	EC-13	<p>Specification connector: JST SM 3P(F)</p> <ul style="list-style-type: none"> • PWM <p>[W: Signal / R: DC+5V / B: GND]</p>
EC-13 ⑧		• Connect to RC receiver or flight controller. (*1)
	EC-13	<p>Specification connector: Servo connector (FUTABA)</p> <ul style="list-style-type: none"> • The starter goes into standby mode when the PWM signal is 1000 μs to 1400 μs. • The PWM signal drives the starter at 1600 μs to 2000 μs. <p>[W: Signal / B: GND] VIH=2.6V, VIL=0.4V, MAX5.5V</p>

*1. The period of the PWM signal input to EC-21 should be 10 to 20 ms (50 to 100 Hz).

Starting the engine

【1】 Fill the fuel tank with fuel before turning on the switches of the ECU and the Igniter.

【2】 If there are air bubbles in the tube between the fuel tank and the fuel pump unit after filling up the fuel tank, open the pressure release valve and eliminate the air bubbles.

NOTE:
Locate the pressure release valve in a place easily accessible to open and close it before/after a day's use.

【3】 Turn on the ECU.

【4】 Power LED is lit and Operation status LED blinks.

【5】 The Fuel pump starts working as soon as the ECU is turned on. If the Pressure release valve is open, close it only after airbubbles in the system are gone. When fuel pressure reaches specified value, the Pump works intermittently or stops.

If the temperature is high (35 ° C or higher) and vapor lock is expected to occur, open the pressure release valve one and a half turns from the fully closed position to circulate fuel between the tank and

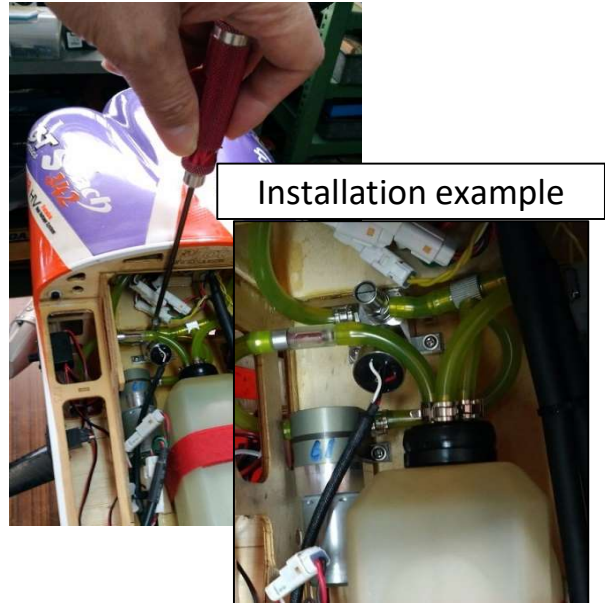

NOTE:
In case the the fuel pressure to the injector doesn't reach the specified value after turning on the switch within 30 seconds, the ECU beeps intermittently and the pump stops. (Turn off the switch and turn it on again when you reset the ECU)

【6】 Move the throttle stick to check the movement of the throttle servo. If the ECU is in starting mode and the Operation status LED is blinking, you can't close the throttle completely but it still remains open a little even if you move the throttle stick fully down. During the start mode, if throttle is open and close in short period, choke function and warning alarm will activate. For detail, please read choke section of the manual.

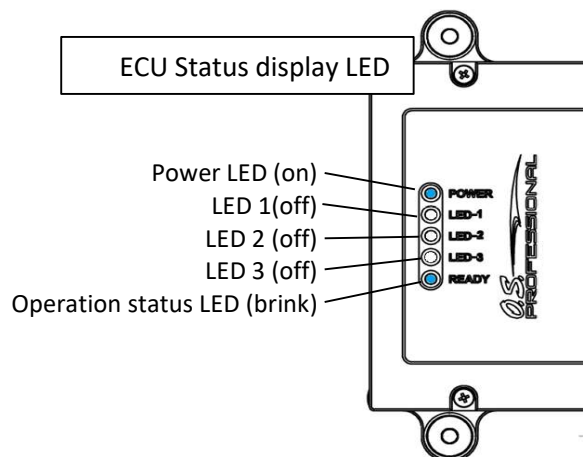

Operation

[8] When the power to the igniter is turned on and the cell starter signal is turned on, SGM cranks and starts the engine.

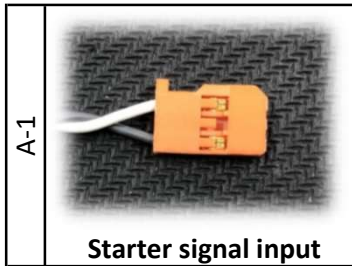

- Starter signal input gives a starter start instruction to the ECU from the connector.
- The starter goes into standby mode when the PWM signal is 1000 μ s to 1400 μ s.
- The PWM signal drives the starter at 1600 μ s to 2000 μ s.

[W: Signal / B: GND] VIH=2.6V, VIL=0.4V, MAX5.5V

NOTE:

- To ensure cranking by SGM, the ECU rotates the crank in the reverse direction (about 180 degrees) to build up compressed pressure of piston and then turns to the forward rotation to start engine.
- SGM cannot crank the engine without the propeller attached because of no inertia.
- If the battery voltage drops below 15.5V, it may not be possible to crank the engine. In that case, start using an external starter or the like.

[9] Engine rpm goes up right after starting the engine, but it goes down immediately.

[10] Idling rpm control system starts working when cylinder head temperature reaches the set temperature otherwise the idling rpm is kept at the set rpm.

• the followings are display LED message's meaning.

	Power LED	LED 1	LED2	LED3	Operation status LED	
engine start mode	On	Off	Off	Off	Blink	
engine operation	On	Blink	Blink	Blink	On	(note.1)
fuel pressure abnormal (pressure low)	On	Blink	Off	Off	Off	at the same time, a buzzer sounds
engine stop	On	Off	Off	On	Off	at the same time, a buzzer sounds
The set parameters are damaged	On	Off	Off	Blink	Off	at the same time, a buzzer sounds
System error 1	On	Blink	Blink	Blink	Blink	at the same time, a buzzer sounds
System error 2	On	Off	Blink	Blink	Off	at the same time, a buzzer sounds

Note.1 since the LED1, LED2 and LED3 are the monitor lamp of each signal, so they flashes at high speed during engine operation.

LED1	Crankshaft rotation sensor signal input
LED2	Injector drive signal output
LED3	Igniter started signal output

Power LED [On: Power ON / Off: Power OFF]
 LED 1
 LED 2
 LED 3
 Operation status LED
 [Blinking: Ready / On: Working / Off: Stopped]

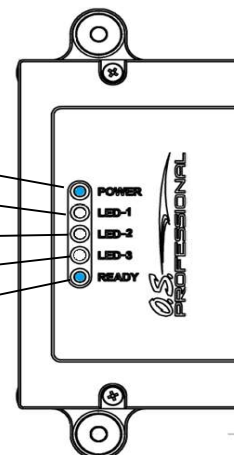

Choke

It is not necessary when starting with a cell starter, but the EC-13 has a choke function in case a choke is required for starting with a safety stick. The choke function works only in the engine start mode. The choking method is as follows.

【1】 In the engine start mode, when the throttle signal is opened from the state where the opening is 20% or less to the opening of 80% or more within 1 second, and then closed to the opening of 20% or less within 1 second, the injector injects the fuel for the choke once. At that time, the ECU sounds the warning alarm once.

【2】 If the same operation is performed again, fuel will be injected in the same way, but in order to prevent over-choke, use the choke function only once or twice, and flip the propeller with a safety stick each time to start the engine while checking for flow of fuel in the fuel line.

CAUTION:

Never start by flipping the propeller directly by hand as it may cause unexpected injuries. Be sure to use a cell starter, an external starter, or a safety stick.

Stopping the engine ①

【1】 Turn off the Ignitor switch to stop the engine.

【2】 The ECU stops the fuel pump and emits Beep sound intermittently when it detects engine stop.

【3】 Turn off the ECU.

【4】 Release the residual pressure in the fuel system after a days use to avoid fuel expanding the fuel joints and causing leaks.

Stopping the engine ②

By using application software(Engine setting_ xxxx.exe)(XXXX is name of the version), the engine stop function can be set. Enter throttle signal and you can use the throttle signal input to instruct the ECU to stop the engine.

《Setting the engine stop function》

【1】 Connection of ECU and PC

• Turn on the switch of the ECU. For connection, use the serial signal converter in the same way as when using EC13-LINK.

【2】 Turning on the ECU

• Turn on the switch of the ECU.

【3】 Starting up the software.

• Execute the file {Engine setting_ xxxx.exe} and open the following window.

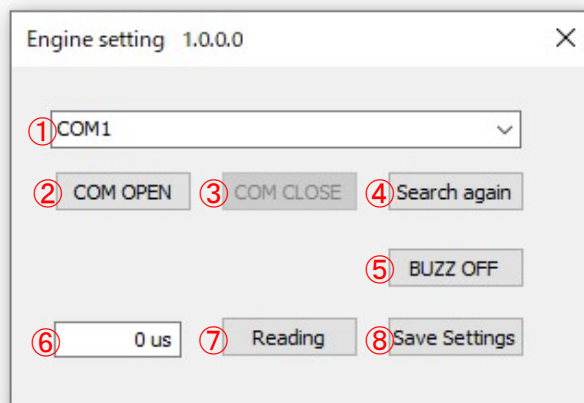

【4】 Confirming COM port assignment.

• Make sure which COM port is assigned to the ECU serial connection by Windows® device manager.
• In case the assigned COM port is other than COM1~COM10, reassign it to one of the port from COM1 to COM10. Refer to the instruction manual of the Windows® you are using how to assign a COM port.

【5】Setting the COM port.

- Select the confirmed COM port from the pull-down menu (① in the above picture). Click the [COM OPEN] button (② in the above picture) and the connection is completed.
- In the pull-down menu of ①, you can see what kind of connection (“USB serial port” in this sample below) next to port number (COM3 in this case). You can make a choice from the pull-down menu. In case you cannot find a connection, click ④ [Search again]. If it's still not displayed, check using the Windows® device manager etc and set up the port number.

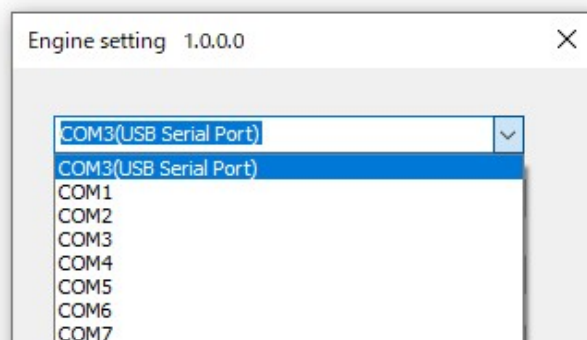

【6】Setting the threshold of pulse width of throttle signal (PWM) in ⑥, which carries out Engine Stop.

- The setting, 0 μ s invalids the Engine Stop operation.
- The setting range is 1~9999 μ s.
- Within the setting range 1~9999 μ s, when the throttle signal input pulse width keeps lower than the setting value for more than 0.5 second, the Engine Stop operation is carried out.

【7】Click the [Save Settings](⑧ in the above picture).

- The new setting is not memorized unless you click [SAVE Setting].

【8】Turn off the ECU and turn it on again to make the setting valid.

After making this setting, the ECU will stop the engine if the PWM signal width of the throttle signal input is held below the set threshold value for 0.5 second or longer.

Restarting the ECU

When the engine stops, the ECU stops the fuel pump, sounds the intermittent warning buzzer, and the engine will go into shut off mode. The engine cannot be restarted in this state.

To restart the engine, it is necessary to restart the ECU. There are three ways to restart the ECU.

- (1) Turn off the power of the ECU and then turn it on again.
- (2) Use the serial communication function to send a restart command to the ECU. (See Communication Protocol section)
- (3) Use the starter signal input to give an instruction to restart the ECU.

On this page, we will explain the method (3).

• Starter signal input connector

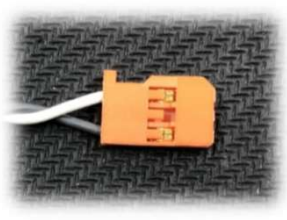
A-1		<ul style="list-style-type: none"> • Input the PWM signal from the external device such as transmitter, flight controller etc. to start the starter motor. • The starter goes into standby mode when the PWM signal is 1000 μs to 1400 μs. • The PWM signal drives the starter at 1600 μs to 2000 μs.
		<p>Specification PWM signal : 1000μs~2000μs</p> <ul style="list-style-type: none"> • The period of the PWM signal input to EC-13 should be 10 to 20 ms (50 to 100 Hz). <p>[W : Signal / B : GND] VIH=2.6V, VIL=0.4V, MAX5.5V</p>

If you input 1600μs to 2000μs of PWM signal from the Starter signal input connector for 2 seconds or more continuously during the engine stop mode, the ECU will restart.

After the ECU restarted, if the PWM signal of the Starter signal input connector becomes 1000 μs to 1400 μs, the starter will be in the standby state.

After the ECU restarted, if the ECU detects the PWM signal of 1600μs~2000μs from the Starter signal input connector continuously, to prevent malfunction, the ECU will enter into engine shutdown mode and cease functioning. In this state, it will not accept restart command. To recover, ECU will need to be turned off and then on again, or to input reset command with serial communication. Bring back the Starter signal input connector's PWM signal to 1000μs~1400μs within 3 seconds after the ECU restarted.

Communication protocol

- ①The internal data of the ECU can be collected by other external devices through its serial communication function.
- ②ECU can be reset by using serial communication function of the ECU.
- The communication protocol would show as followings.

《communication specification》

- UART
- TTL logic level 3.3V
- Pin assignment (ECU side connector)

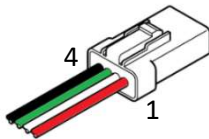

1	red	+5V power supply output
2	white	TXD
3	green	RXD
4	black	GND

connector : JST 04R-JWPF-VSLE-S

- protocol

bit rate	38400 bps
data length	8 bit
parity bit	none
stop bit	1bit
flow control	none
frame length	changeable

《communication procedure》

- normal

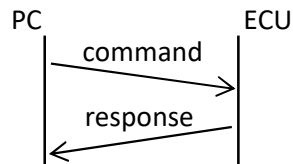

- abnormal (response postpone)

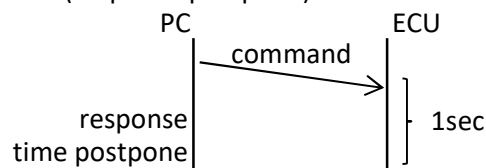

- abnormal (command BCC error)

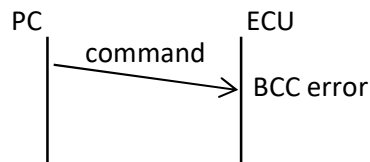

- abnormal (response BCC error)

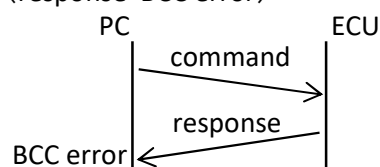

Communication protocol

①《Data collection》

• command format

item	size	data	range
start mark	1 byte	02h	02h(2)
command	3 byte	"MOR"	4Dh、4Fh、52h
end mark	1 byte	03h	03h(3)
BCC(XOR from command to end mark)	1 byte	53h	53h

• response format

item	size	data	range		
start mark	1 byte	02h	02h(2)		
status	1 byte	"0"	30h(48)		
	1 byte	" "	20h(32)		
DATA	① barometric pressure	unit: hPa	4byte	"8000"~"7FFF"	8000h~7FFFh (-32768~32767)
			1 byte	" "	20h(32)
	② fuel pressure	unit: kPa	4byte	"8000"~"7FFF"	8000h~7FFFh (-32768~32767)
			1 byte	" "	20h(32)
	③ (Reserved)*	unit: hPa	4byte	"8000"~"7FFF"	8000h~7FFFh (-32768~32767)
			1 byte	" "	20h(32)
	④ (Reserved)*	unit:	4byte	"8000"~"7FFF"	8000h~7FFFh (-32768~32767)
			1 byte	" "	20h(32)
	⑤ power supply (ECU internal 3.3V)	unit: mV	4byte	"8000"~"7FFF"	8000h~7FFFh (-32768~32767)
			1 byte	" "	20h(32)
	⑥ power supply (ECU internal 5V)	unit: mV	4byte	"8000"~"7FFF"	8000h~7FFFh (-32768~32767)
			1 byte	" "	20h(32)
	⑦ power supply (ECU internal 12V)	unit: mV	4byte	"8000"~"7FFF"	8000h~7FFFh (-32768~32767)
			1 byte	" "	20h(32)
	⑧ cylinder head temperature	unit: °C	4byte	"8000"~"7FFF"	8000h~7FFFh (-32768~32767)
			1 byte	" "	20h(32)
	⑨ (Reserved)*	unit:	4byte	"8000"~"7FFF"	8000h~7FFFh (-32768~32767)
			1 byte	" "	20h(32)
	⑩ throttle signal input from receiver (fully close~fully open 0%~100%)	unit: %	4byte	"8000"~"7FFF"	8000h~7FFFh (-32768~32767)
			1 byte	" "	20h(32)
	⑪ signal output to throttle servo (fully close~fully open 0%~100%)	unit: %	4byte	"8000"~"7FFF"	8000h~7FFFh (-32768~32767)
			1 byte	" "	20h(32)
	⑫ fuel trim signal input from receiver (PWM signal pulse wide range)	unit: μs	4byte	"8000"~"7FFF"	8000h~7FFFh (-32768~32767)
			1 byte	" "	20h(32)
	⑬ engine rotation speed	unit: rpm	4byte	"8000"~"7FFF"	8000h~7FFFh (-32768~32767)
	end mark	1 byte	03h	03h(3)	
BCC(XOR from status to end mark)	1 byte				

*The (Reserved) item is not used in EC-13. The value is readable but it does not mean anything.

Communication protocol

②《Restarting ECU》

• command format

item	size	data	range
start mark	1 byte	02h	02h(2)
command	9 byte	"rstrsrst"	72h、73h、74h、 72h、73h、74h、 72h、73h、74h、
end mark	1 byte	03h	03h(3)
BCC(XOR from command to end mark)	1 byte	76h	76h

item	size	data	range
start mark	1 byte	02h	02h(2)
status	1 byte	"0"	30h(48)
end mark	1 byte	03h	03h(3)
BCC(XOR from status to end mark)	1 byte	33h	33h

《CAN setting software》

Use the serial signal converter and the CAN setting software {CAN setting_ xxxx.exe} (xxxx is the version name) to set the CAN of the ECU.

【Separately required items】

• PC with Windows® (10/11) and USB port. The included U2S-2 (serial signal converter) uses an FTDI chip, the driver is registered in Windows® Update. Therefore, in internet environment, the driver is automatically downloaded and installed by connecting the USB serial converter to the PC. Install the driver in advance in an internet environment.

【Installing software into PC】

• There is no installation program for CAN setting software. Copy the software {CAN setting_ xxxx.exe} to any location on your computer (hereafter PC). After copying it to any location, execute {CAN setting_ xxxx.exe} directly.

• When deleting the software, delete the {CAN setting_ xxxx.exe} file from the PC.

《Setting》

【1】Connecting serial signal port

• Connect the 4-pin connector of U2S-2 to the ECU's serial communication connector (A-2).

• Connect the U2S-2 main unit to the USB port of the PC.

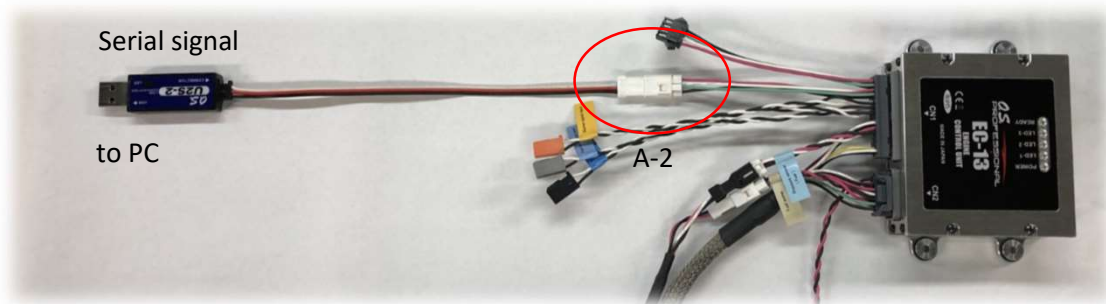

【2】Powering the ECU

• Turn on the power of ECU

CAUTION :

- Do not turn on the ECU if the fuel is not going into the fuel pump. If fuel pump runs without any fuel, it may cause damage to the pump.
- If you need to power on the ECU without fuel, such as when changing settings using CAN configuration software, disconnect the pump connector and do not operate the pump. In that case, the buzzer (alarm) sounds due to abnormal fuel pressure 30 seconds after the ECU is turned on, but you can stop the buzzer by clicking the "BUZZ OFF" button in the CAN setting software.

【3】Starting up the software

- Execute {CAN setting_ xxxx.exe} copied to the PC. The window will open (picture below).

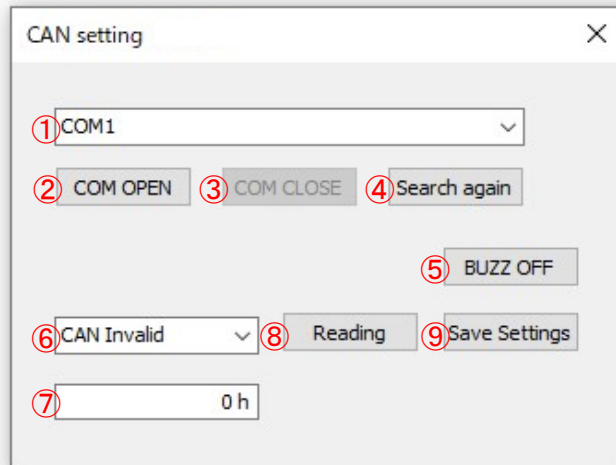

【4】Confirming the COM port allocation

- Check which COM port the serial connection with the ECU is assigned to, using Windows® Device Manager, etc.
- At this time, if it is allocated outside the range of COM1 to COM10, change it to one of COM1 to COM10. For how to change, refer to the operation method of each Windows® you are using.

【5】Setting COM port

- Select the confirmed COM port from the pull-down menu (① in the above picture). Click the [COM OPEN] button (② in the above picture) and the connection is completed.
- In the pull-down menu of ①, you can see what kind of connection ("USB serial port" in this sample below) next to port number (COM3 in this case). You can make a choice from the pull-down menu. In case you cannot find a connection, click ④ [Search again]. If you still can't see it, check Windows® Device Manager and set the port number.

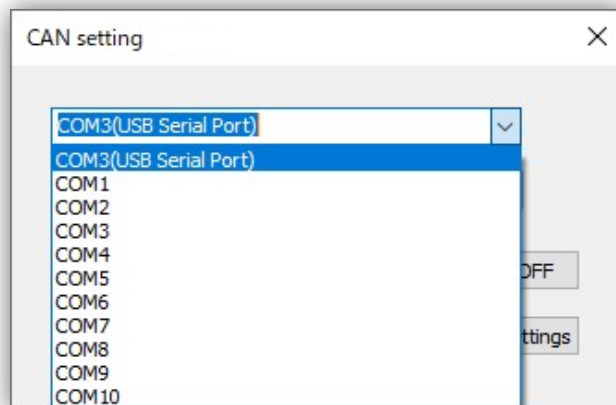

【6】Select CAN Invalid or communication speed from the pull-down menu in ⑥.

- Communication speed can be selected from 125Kbps, 250Kbps, 500Kbps, 1Mbps and CAN Invalid.
- If the communication speed is specified, CAN will be valid and the ECU will send data for ID: 0x0300 to 0x030C(default) only once at intervals of about 100ms. With this CAN system, the data cannot be resent in case of an error.
- Refer to page 50 for the data format.

【7】Determine and input the start point of CAN ID in ⑦.

- 0x0h ~ 0x7FF can be used.
- The CAN communication occupies 13 IDs including the start point.
- In case 0x7FF is determined, the ID circulates like 0x7FF, 0x0, 0x1, 0xA.
- Do not use the same ID of other devices connected to the CAN.

【8】Click the [Save Settings](⑧ in the above picture).

- The new setting is not memorized unless you click [SAVE Setting].

【9】Turn off the ECU and turn it on again to make the setting valid.

Communication Protocol

• The internal data of the ECU can be collected by other external devices through its CAN communication function. The communication protocol would show as followings.

《communication specification》

- CAN
- Pin assignment (ECU side connector)

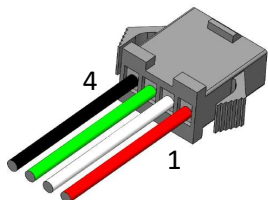

1	red	+5V power supply output
2	white	Signal(High)
3	green	Signal(Low)
4	black	GND

connector : JST SMR-04V-BC

《data format》

- Data frame

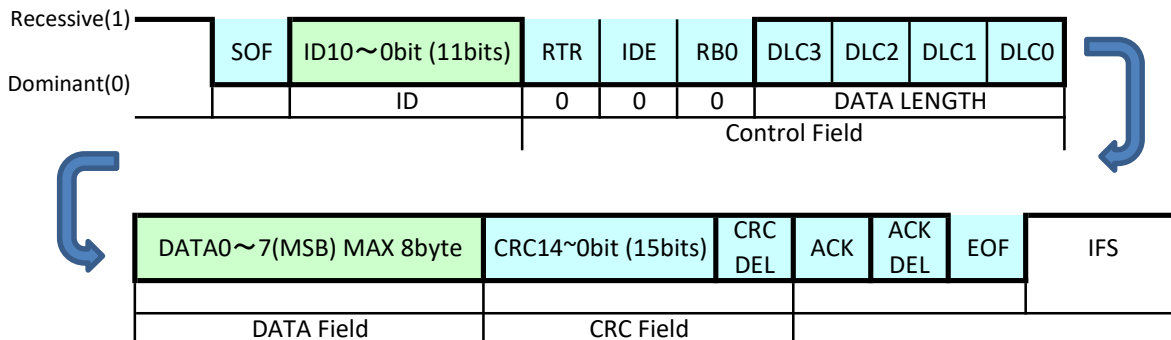

- DATA

NAME	ID		DATA LENGTH	DATA 0~7		DATA RANGE
				0~5	6~7	
barometric pressure (hPa)	768	0x0300	8	0x000000000000	DATA	0x8000 (-32768) ~ 0x7FFF (32767)
Fuel pressure (kPa)	769	0x0301	8	0x000000000000	DATA	
(reserved)*	770	0x0302	8	0x000000000000	DATA	
(reserved)*	771	0x0303	8	0x000000000000	DATA	
3.3V voltage (mV)	772	0x0304	8	0x000000000000	DATA	
5V voltage (mV)	773	0x0305	8	0x000000000000	DATA	
12V voltage (mV)	774	0x0306	8	0x000000000000	DATA	
Head temperature (°C)	775	0x0307	8	0x000000000000	DATA	
(reserved)*	776	0x0308	8	0x000000000000	DATA	
Throttle signal input (%)	777	0x0309	8	0x000000000000	DATA	
Throttle signal output (%)	778	0x030A	8	0x000000000000	DATA	
Trim signal Width (μs)	779	0x030B	8	0x000000000000	DATA	
Rotation speed (rpm)	780	0x030C	8	0x000000000000	DATA	

*The (Reserved) item is not used in EC-13. The value is readable but it does not mean anything.

ECU connector pin assignment

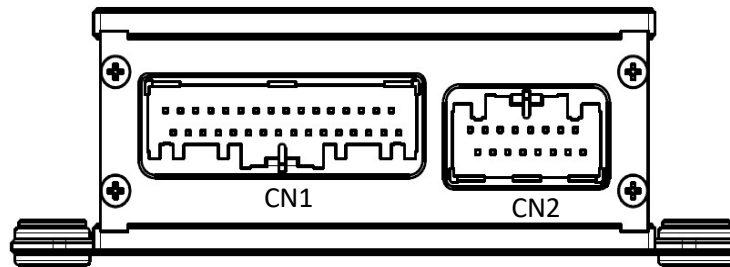

【CN1】

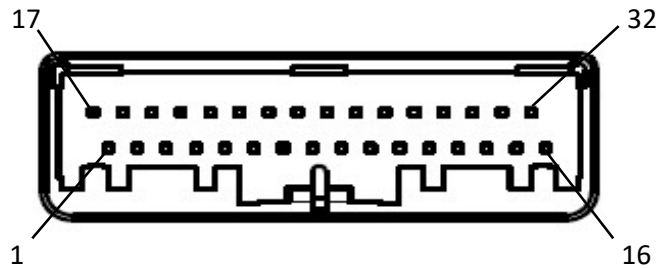

1	CAN[High]	17	CAN[Power supply DC+5V]
2	CAN[GND]	18	CAN[Low]
3	Serial communication[TX]	19	Serial communication[Power supply DC+5V]
4	Serial communication[GND]	20	Serial communication[RX]
5	Throttle signal input[SIGNAL]	21	Power supply DC+5V (Expansion)
6	Fuel trim signal input[SIGNAL]	22	Throttle signal input[GND]
7	Starter signal input[SIGNAL]	23	Fuel trim signal input[GND]
8	(Reserved)	24	Starter signal input[GND]
9	Crankshaft rotation sensor[+5V]	25	(Reserved)
10	Crankshaft rotation sensor[GND]	26	Crankshaft rotation sensor[SIGNAL]
11	Fuel pressure sensor[SIGNAL]	27	Fuel pressure sensor[+5V]
12	(GND)	28	Fuel pressure sensor[GND]
13	(Reserved)	29	(Reserved)
14	(Reserved)	30	(Reserved)
15	Cylinder head temperature sensor[+]	31	(Reserved)
16	GND(Shield)	32	Cylinder head temperature sensor[-]

Not connected except to enclose with

ECU connector pin assignment

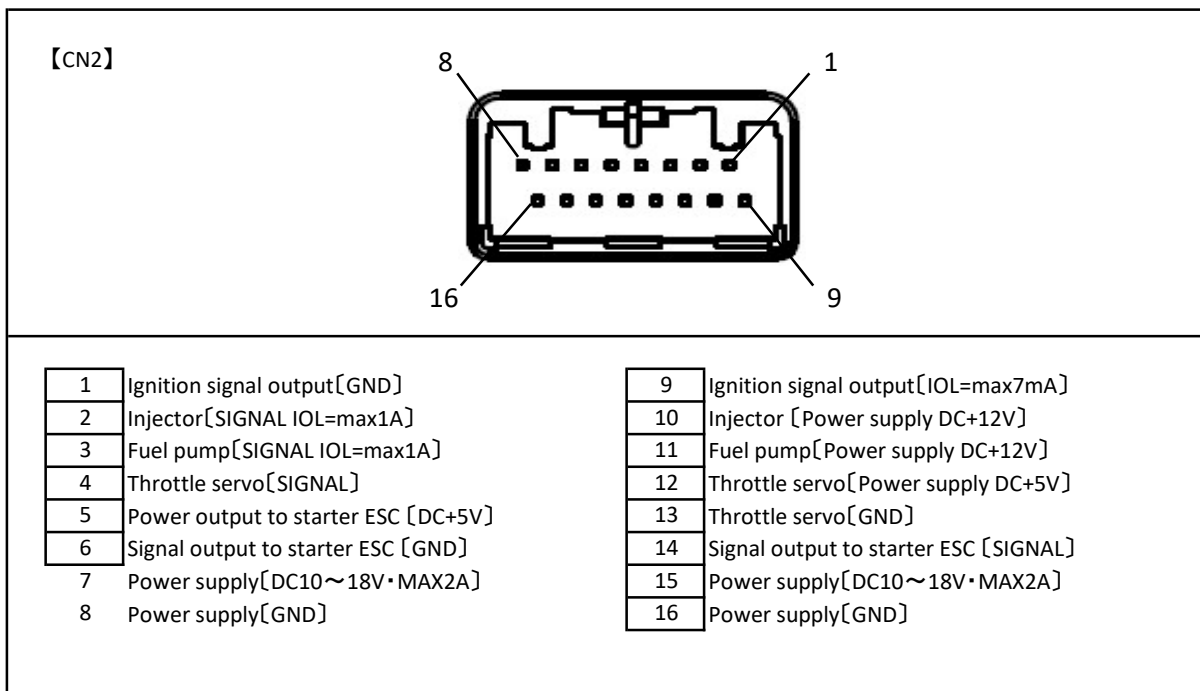

Not connected except to enclose with

Engine parts list

■ENGINE PARTS LIST / GF80TU-FI W/SGM (1/3)		
No.	Code No.	Description
1	4AL01000	CRANKCASE GF80TU
2	74002A20	ROTATION SENSOR IG-10
3	74002321	ROTATION SENSOR FIXING SCREW (2PCS)
4	29730000	BALL BEARING(FF)
5	4AL30000	BALL BEARING(FR)
6	4AD30000	BALL BEARING(RF)
7	4AL31000	BALL BEARING(RR)
8	45231100	CAMSHAFT BEARING (1PC)
9	4AL02000	CRANKSHAFT GF80TU
10	29708200	PARAREL KEY (1PC)
11	4AD62000	CAMSHAFT(F)
12	4AL62000	CAMSHAFT(R)
13	4AL01100	CAM COVER (1PC)
14	4AL01101	CAM COVER O-RING (1PC)
15	4AL08000	DRIVE SPACER GF80TU
16	29708100	TAPER COLLET
17	28602100	PILOT SHAFT
18	79872100	WASHER 10.0
19	29709000	PROPELLER WASHER
20	4AL28003	MOUNTING PLATE GF80TU
21	4AL81201	THROTTLE SERVO MOUNT GF80TU (1PC)
22	4AD81221	THROTTLE SERVO
23	4AD81401	THROTTLE SERVO HORN
24	4AD81205	THROTTLE SERVO PLATE (1PC)
25	4AL81202	THROTTLE LINK ROD
26	4AL03300	CYLINDER GF80TU (1PC)
27	29122540	SILENCER GASKET (O-RING)
28	4AL03200	PISTON (1PC)
29	49403400	PISTON RING (1PC)
30	49406010	PISTON PIN (1PC)
31	29717000	PISTON PIN RETAINER (2PCS)
32	4AL04000	CYLINDER HEAD (1PC)
33	49404160	HEAD GASKET (1PC)
34	54056014	ST-02 TEMPERATURE SENSOR (1PC)
35	4A004200	ROCKER COVER (1CP)
36	44514300	ROCKER COVER GASKET (1PC)
37	45761600	ROCKER ARM RETAINER (2PCS)
38	49464000	ROCKER SUPPORT (1PC)
39	4AD61100	ROCKER ARM (1PC)
40	44561200	TAPPET ADJUSTING SCREW (1PC)
41	45560410	COTTER PIN (2PCS/1PAIR)
42	49460400	VALVE SPRING RETAINER (1PC)
43	49460200	VALVE SPRING (1PC)
44	49460110	POPPET VALVE (1PC)
45	4AD66000	PUSH ROD (2PCS)
46	45566310	PUSH-ROD COVER O-RING (2PCS)
47	49466100	PUSH ROD COVER (1PC)
48	44564000	CAM FOLLOWER (2PCS)
49	4AL69401	INTAKE MANIFOLD A GF80TU
50	4AL14010	INTAKE MANIFOLD A GASKET GF80TU
51	4AL69402	INTAKE MANIFOLD B GF80TU (1PC)
52	49414010	INTAKE MANIFOLD GASKET (2PCS)
53	4AL69403	INTAKE PIPE GF80TU (1PC)
54	4AA07410	O-RING (1PC)

Engine parts list

■ENGINE PARTS LIST / GF80TU-FI W/SGM (2/3)		
No.	Code No.	Description
55	4AL16100	REED VALVE MOUNT GF80TU
56	4AL15001	REED VALVE MOUNT GASKET GF80TU
57	4AL15002	REED VALVE GASKET GF80TU (1PC)
58	4AL16000	REED VALVE ASSEMBLY GF80TU
59	4AL81100	THROTTLE BODY GF80TU
60	4AL81200	THROTTLE VALVE GF80TU
61	54057025	O-RING THROTTLE VALVE
62	4AD81400	THROTTLE ARM
63	4AL81220	ROTOR GUIDE WASHER
64	4AD84000	INJECTOR
65	4AD84003	INJECTOR RING SEAL
66	4AD84004	INJECTOR O-RING
67	4AD84014	INJECTOR WIRE HARNESS
68	4AD84005	INJECTOR SPACER (2PCS)
69	4AD83300	INJECTOR COUPLER
70	4AD81950	FUEL INLET (1SET)
71	4AL12000	AIR CLEANER ADAPTER GF80TU
72	4AL15003	AIR CLEANER ADAPTER GASKET GF80TU
91	54085001	SGM-8020 (GF80TU)
92	54085006	STATOR RETAINER
93	45520000	THRUST WASHER
94	54085007	ROTOR STOP SCREW GF80TU
95	74003590	M5 STAND OFF ENGINE MOUNT 60mm (4PCS)
96	55500004	NORD LOCK WASHER M5 (10PCS.)
97	4AL25000	SILENCER F-6050 (1PC)
98	4AL25003	SILENCER BODY F-6050 (1PC)
99	4AL26000	EXHAUST HEADER PIPE F-6050 (1PC)
100	4AL24000	ALUMINUM SPINNER
101	4AG81000	AIR CLEANER UNI (PK-4E)
C1	79871020	HEXAGON HEAD SCREW M2.6X7 (10PCS/SET)
C2	79871030	HEXAGON HEAD SCREW M2.6X10 (10PCS/SET)
C3	79871110	HEXAGON HEAD SCREW M3.0X 8(10PCS/SET)
C5	79871140	HEXAGON HEAD SCREW M3.0X12(10PCS/SET)
C6	79871410	HEXAGON HEAD SCREW M4.0X10 (10PCS/SET)
C7	79871415	HEXAGON HEAD SCREW M4.0X15(10PCS/SET)
C8	79871425	HEXAGON HEAD SCREW M4.0X25(10PCS/SET)
C9	79871430	HEXAGON HEAD SCREW M4.0X30(10PCS/SET)
C10	79871520	HEXAGON HEAD SCREW M5.0X20(10PCS/SET)
C11	79871525	HEXAGON HEAD SCREW M5.0X25(10PCS/SET)
C12	79871540	HEXAGON HEAD SCREW M5.0X40 (10PCS/SET)
C13	79875616	HEXAGON FLAT-H SCREW M6.0X16(10PCS/SET)
E1	75005100	EC-13 ENGINE CONTROL UNIT (FOR W/SGM)
E2	75005101	EC-13 ECU (FOR W/SGM)
E3	75000007	MOUNT COLLAR (4PCS)
E4	75005102	ECU WIRE HARNESS EC-13 (FOR W/SGM)
E5	75005012	POWER SUPPLY CORD EC-13
E6	75000206	CAN COMMUNICATION CORD
E7	74001210	U2S-2 SERIAL SIGNAL CONVERTER
E8	54055002	ORF-200(FOR SGM)
E9	54086001	SGC-2100HV
E10	54088001	CC-100(4S)
P1	54087000	PM-02A FUEL PUMP UNIT
P2	72500010	PUMP MOUNTING PLATE
S1	54058013	SP-01 FUEL PRESSURE SENSOR UNIT

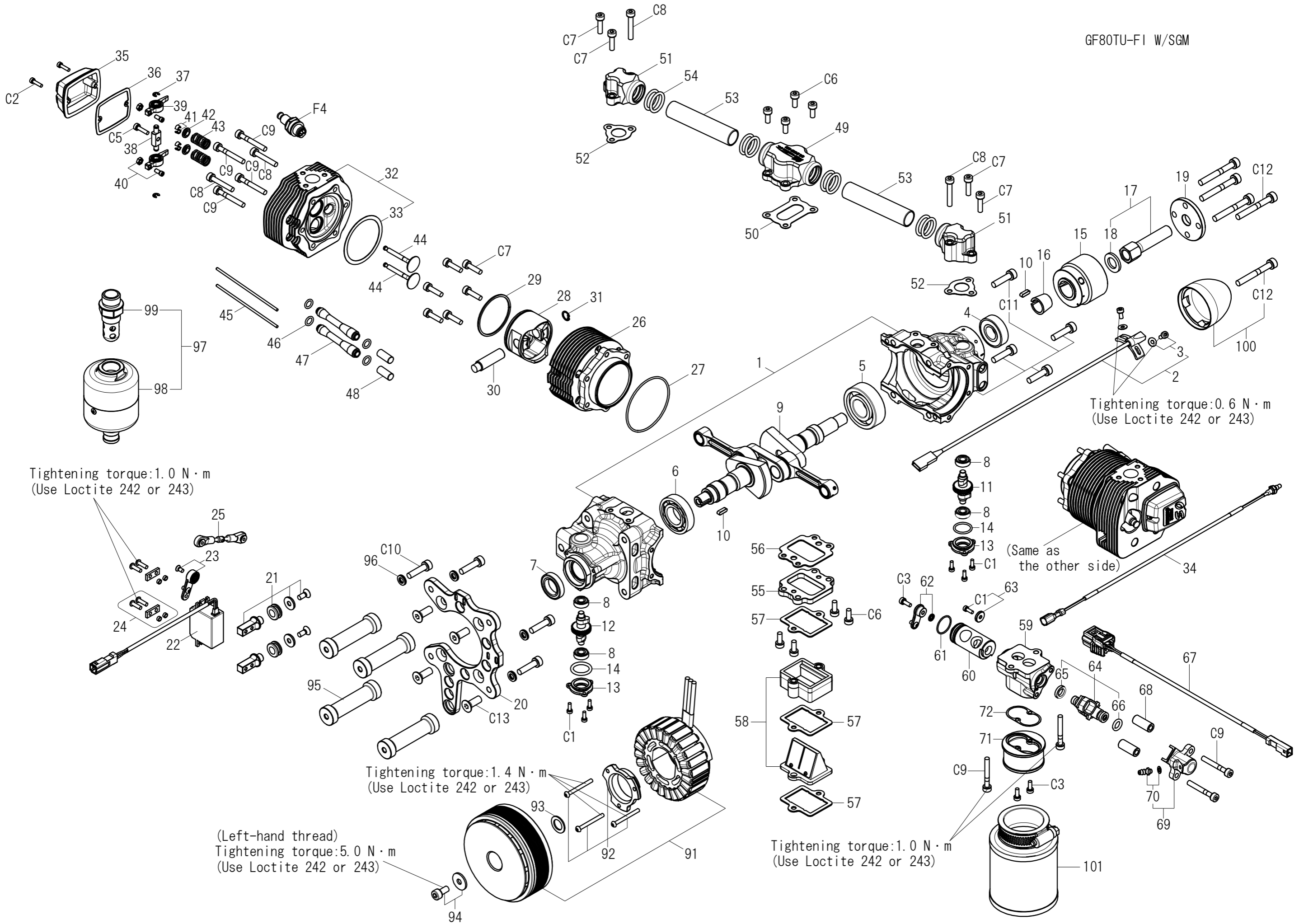

Tightening torque:1.0 N·m
(Use Loctite 242 or 243)

Tightening torque:0.6 N·m
(Use Loctite 242 or 243)

(Same as the other side)

Tightening torque:1.4 N·m
(Use Loctite 242 or 243)

(Left-hand thread)
Tightening torque:5.0 N·m
(Use Loctite 242 or 243)

Tightening torque:1.0 N·m
(Use Loctite 242 or 243)

EC-13 ENGINE CONTROL UNIT

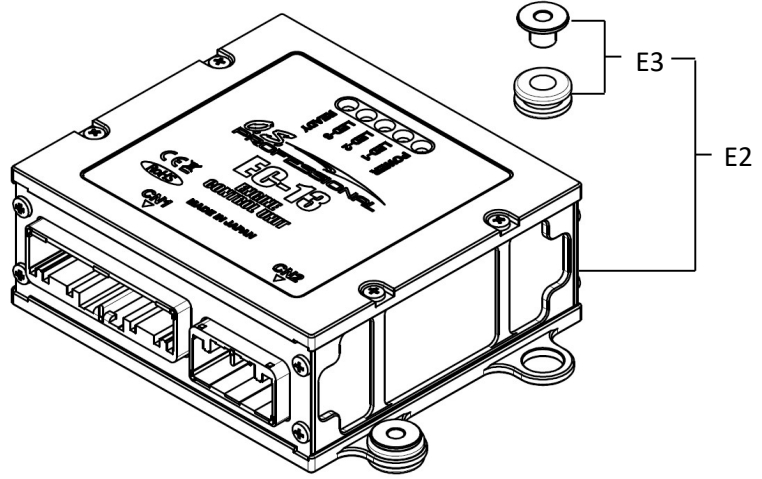

ECU WIRE HARNESS EC-13 (FOR W/SGM)

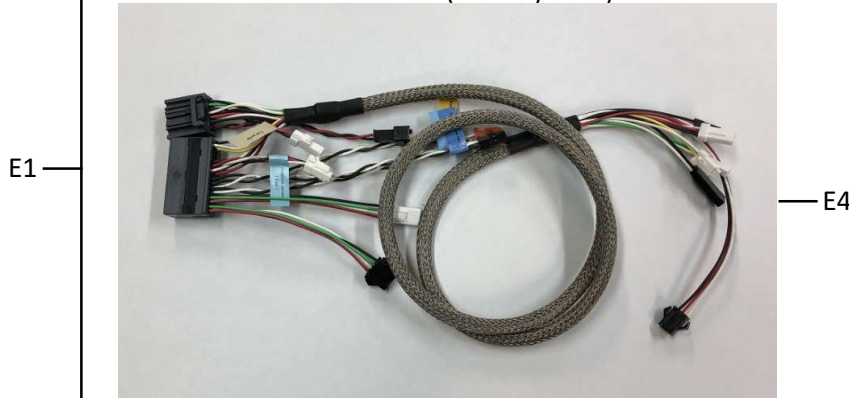

POWER SUPPLY CORD EC-11



CAN COMMUNICATION CODE

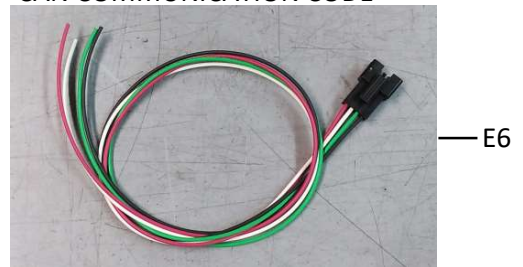

SERIAL SIGNAL CONVERTER



Engine parts list

E8	 A silver, rectangular electronic component with a finned heat sink. It has two yellow connectors on the left side and a bundle of wires (red, black, and white) extending from the top.	ORF-200(FOR SGM)
E9	 A black, rectangular electronic component with a finned heat sink. It has two yellow connectors on the right side and a bundle of wires (black, red, and white) extending from the top.	SGC-2100HV
E10	 A black, rectangular electronic component with a finned heat sink. It has two yellow connectors on the left side and a bundle of wires (red, black, and white) extending from the top.	CC-100(4S)

Engine parts list

PM-02A FUEL PUMP UNIT

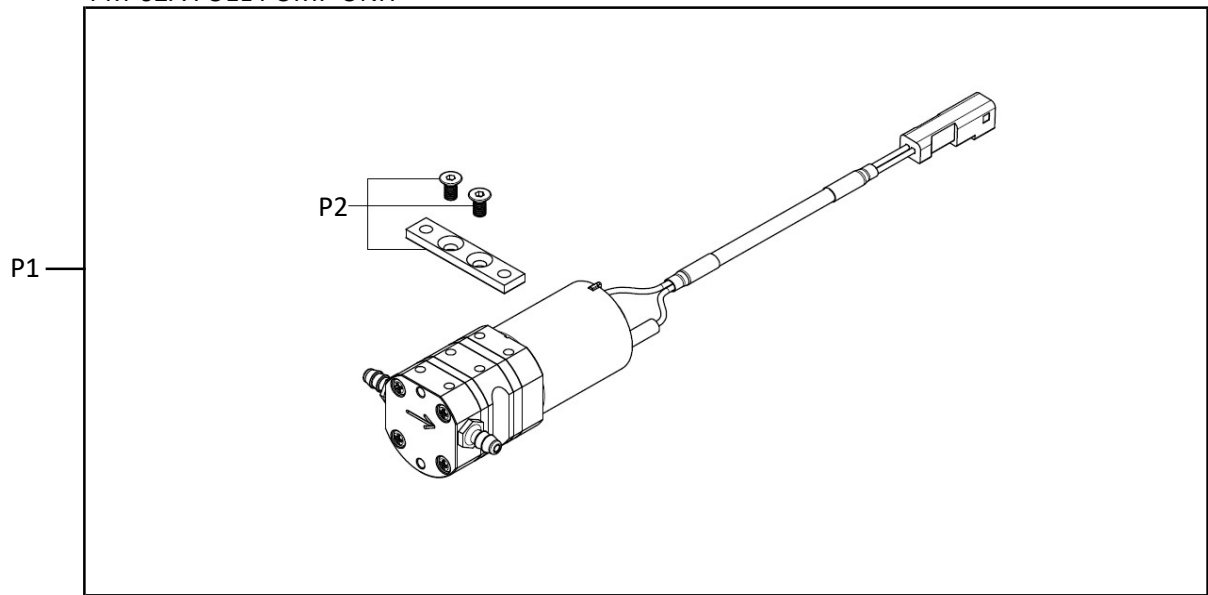

SP-01 FUEL PRESSURE SENSOR UNIT

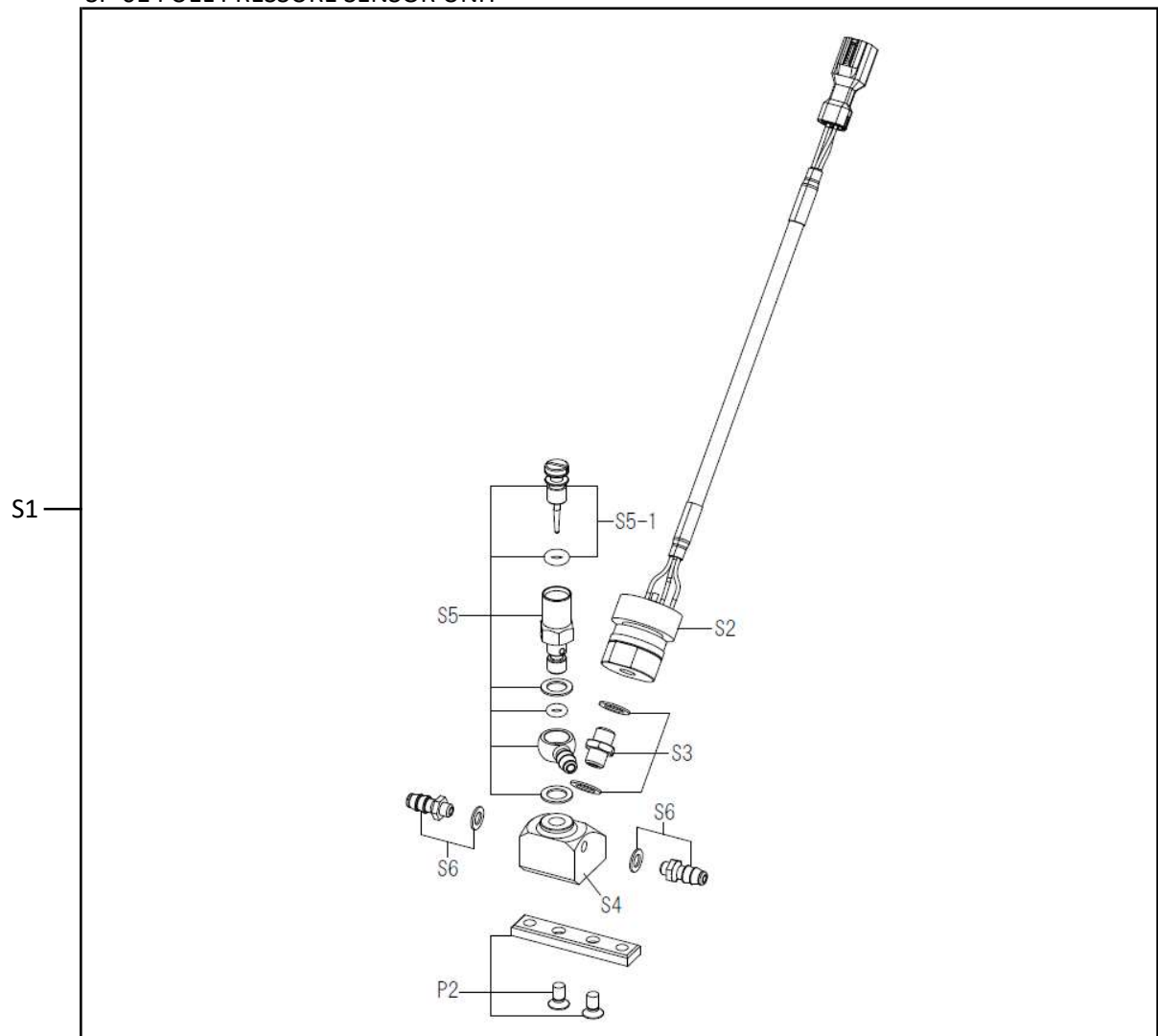

Engine parts list

F1	A black braided cable with a white connector on one end and a black connector on the other.	PUMP CONNECTION CORD (50cm)
F2	A small rectangular metal box with 'GAS POWER' and 'IG-12' printed on it, connected to various wires.	IGNITION MODULE (IG-12)
F3	A long, cylindrical metal socket wrench.	SOCKET WRENCH FOR TEMPERATURE SENSOR
F4	A yellow box labeled 'SR12 CM-6' and a single spark plug.	SPARK PLUG CM-6(NGK)
F5	Five small metal hose clips arranged in two rows.	HOSE CLIP 6 (5pcs.)
F6	A small cylindrical fuel filter with a blue cap and a white body.	GASOLINE FUEL FILTER S
F7	A small metal weight with a porous, spherical end.	NON-BUBBLE WEIGHT S

Engine parts list



CONNECTOR LOCK (5pcs.)



FLUORINE(ETFE) RESIN TUBING (2m)
(EIGHTRON Flexible Fluorine (ETFE) Resin Tubing Clear
made by HAKKO CORPORATION / JAPAN)



VALVE ADJUSTING TOOL KIT GF
(Option)

Measurements

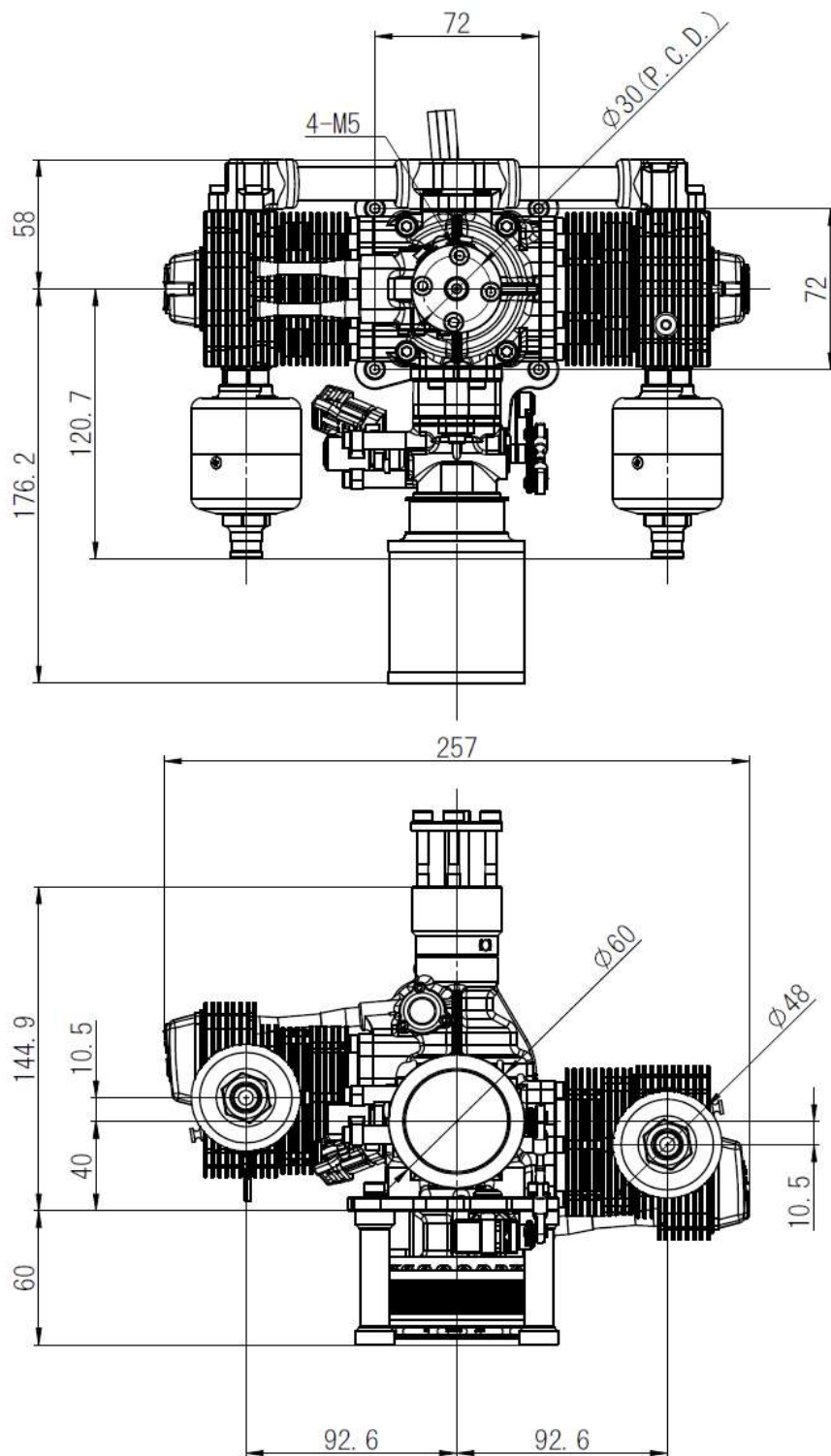

GF80TU-FI With SGM-8020

Unit : mm

Measurements

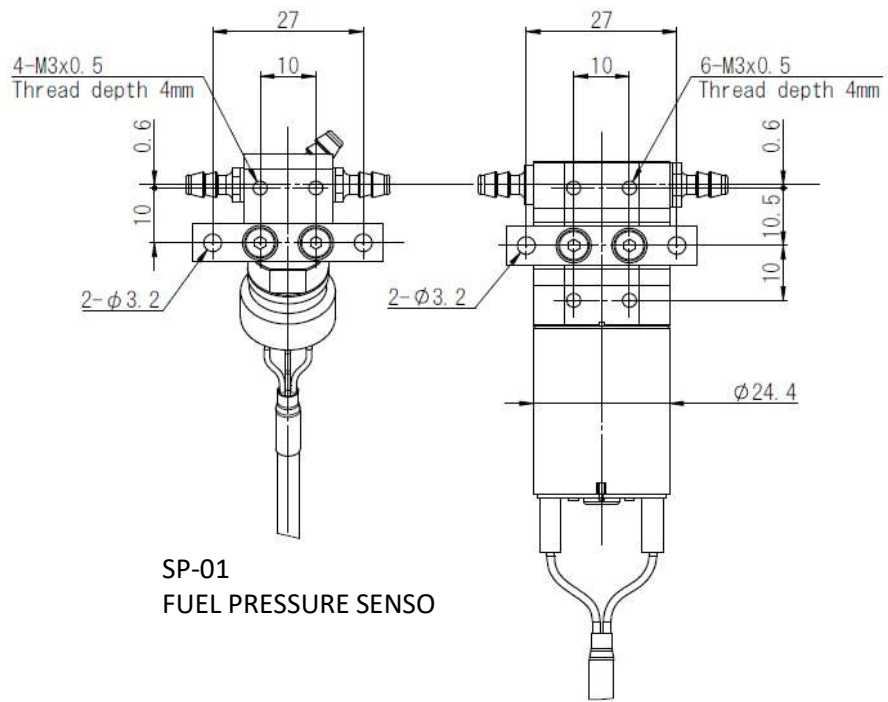
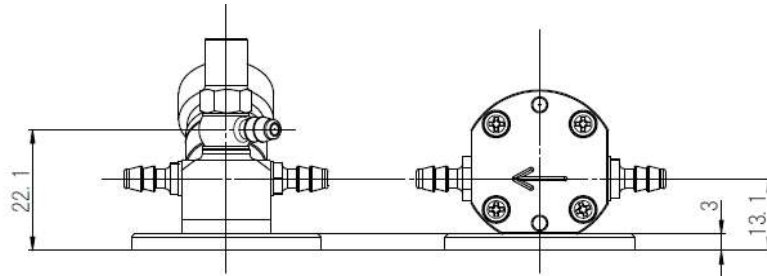

SP-01
FUEL PRESSURE SENSO

PM-02A
FUEL PUMP UNIT

Unit : mm

Measurements

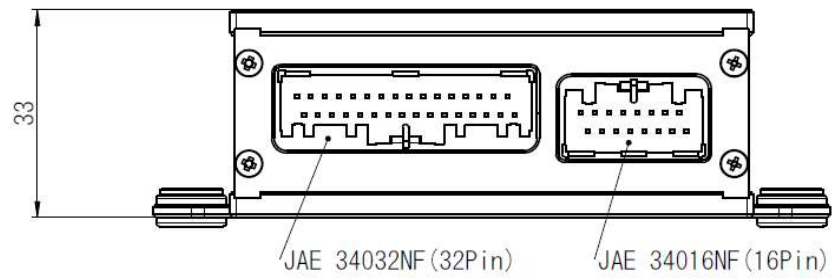
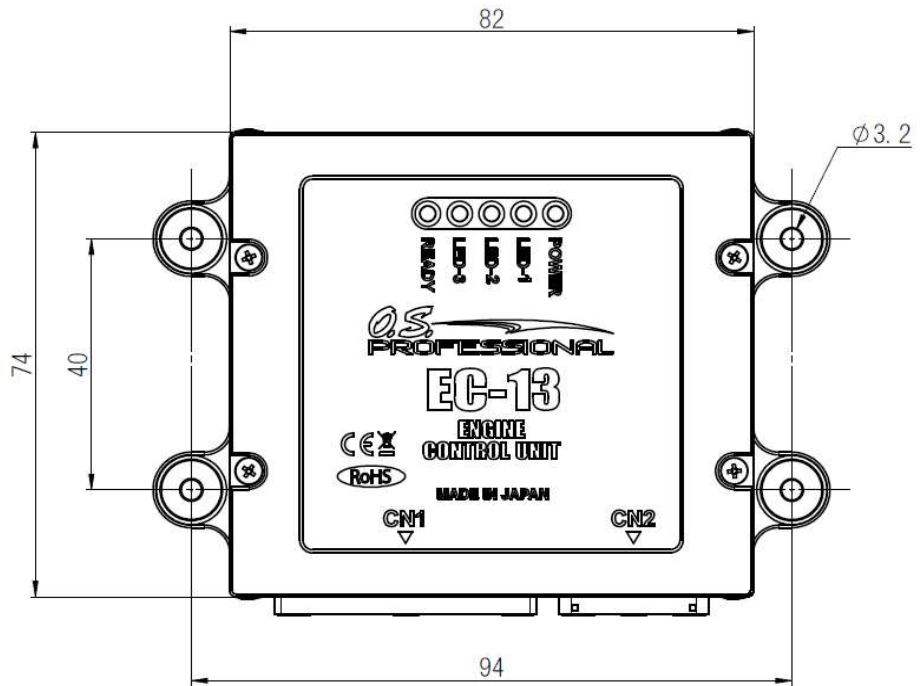

EC-13
ENGINE CONTROL UNIT

Unit : mm

Measurements

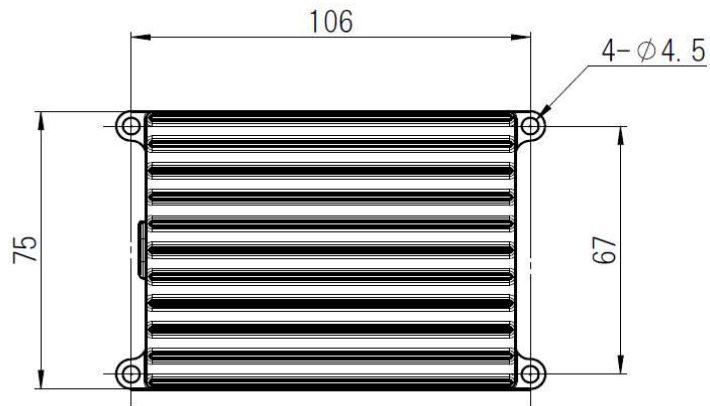

ORF-200(FOR SGM)
Regulator rectifier

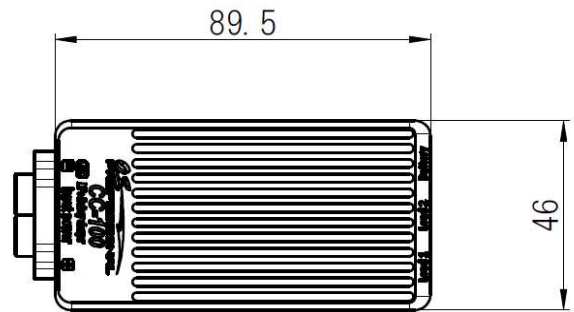
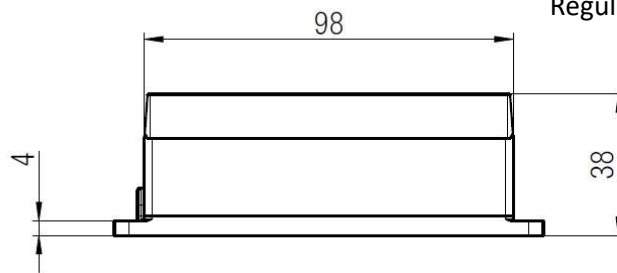

CC-100(4S)
4S Li-Po Battery charger

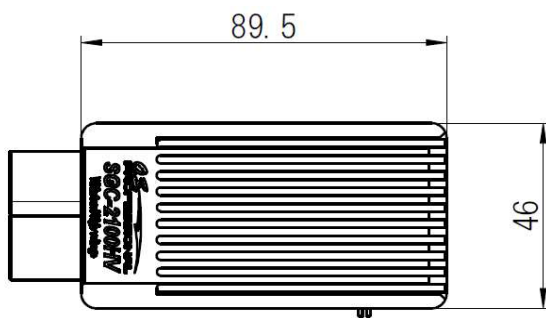
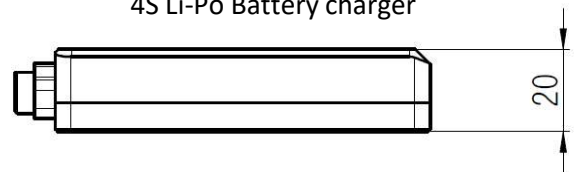

SGC-2100HV
SGC(ESC)

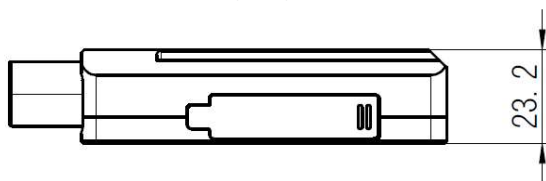

Unit : mm

MEMO