

4 stroke gasoline engine for UAV

GF80TU2-FI With SGM

With EC-23 (ECU)

INSTRUCTION MANUAL

version 1.0E
2026.05.01

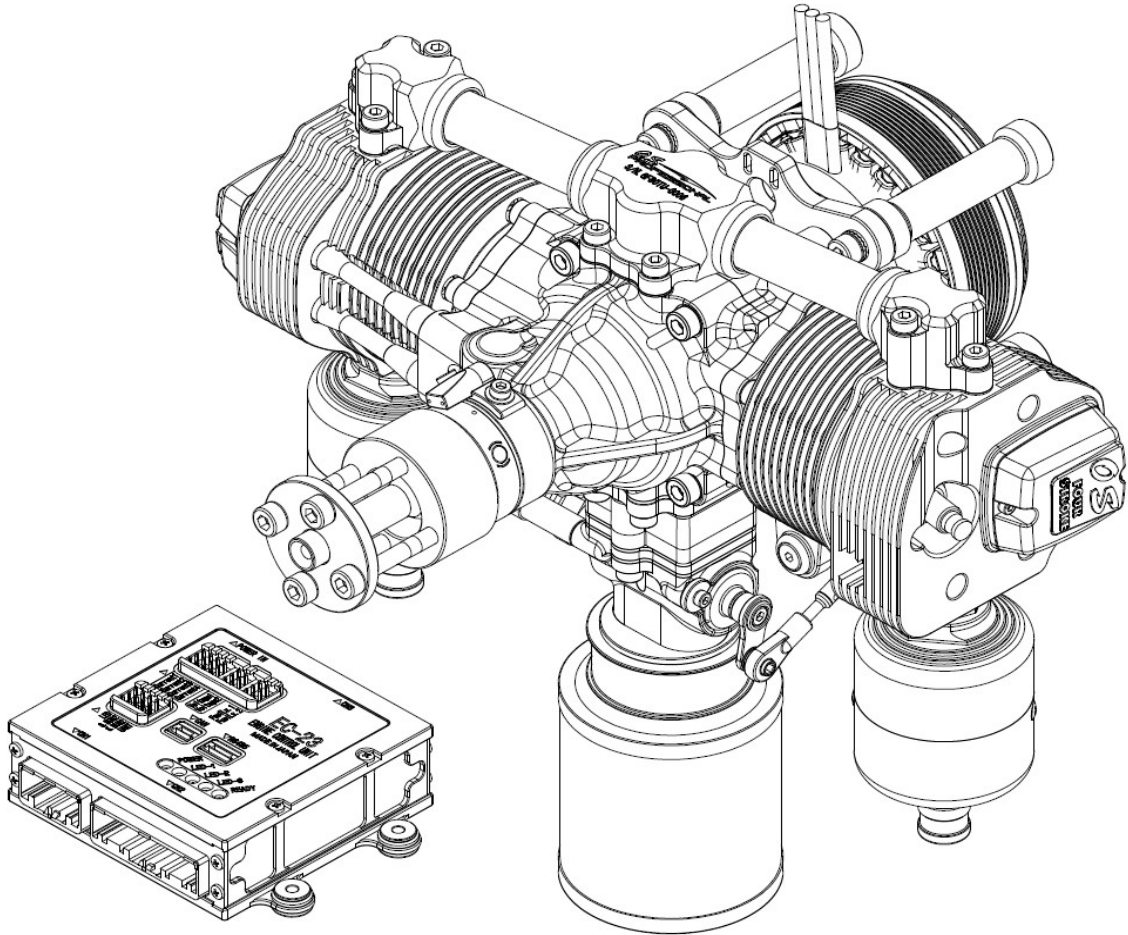

O.S. ENGINES MFG. CO., LTD.

Table of contents

	Page
1.About the engine	2
2.Names of the parts	3
3.Accessories	7
4.Standard screw tightening torque	11
5. Installation	
Standoff engine mount	12
Fuel delivery	14
Silencer	18
Propeller	19
Plug cap	20
6.Engine Control Unit(ECU)	
ECU	21
ECU Wiring harness	22
About connection via S.BUS	24
About connection via CAN	24
About connection via RS485	24
7.Starter Generator Motor(SGM)	
System configuration	27
Connection	28
8.Zero point calibration of current sensor	
Zero point calibration of current sensor	33
9.EC23-LINK	
Preparation	36
Connecting EC23-LINK	37
Setting various settings	40
MONITOR function	46
10.How to operate the engine	
Starting the engine	49
Choke	52
Stopping the engine	53
Restarting ECU	55
11.ECU Communication protocol	
Serial(COM) communication	56
CAN communication	61
Serial(RS485) communication	68
12.Assignment of the pins	72
13.Engine parts list	76
14.Measurements	85

1.About the engine

- Please read this instruction manual and all attached instructions carefully before handling the engine.

【ENGINE】

- The engine is equipped with electronic fuel injection system to correspond to environmental changes during a long flight.
- This is a four stroke gasoline engine, but runs on a premixed gasoline/2-stroke engine oil.
- Use high quality commercially available 2-stroke engine oil(JASO FD/ISO-L-EGD).
- The oil to be mixed with gasoline should be commercially available 2-stroke engine oil. Follow the oil manufacture's recommendations regarding the fuel and oil mixture ratios. If there is no recommendation, we recommend 50:1 mixture ratio.
- The engine runs counter-clockwise when viewed from the front.
- Recommended propellers are 22x8-12, 23x8-12, 24x8-10 (DxP Inch). We recommend a propeller whose rpm is within range of 6500rpm~8000rpm at full throttle.
- SGM (starter generator motor) is directly mounted on the crank shaft behind the engine. It is a 200W class generator (Max. 200W/20min. Constant rating: 120W) and has the ability as a cell starter at the time of starting.
- The system power supply should be 12(S)cell (Max50.4V)with two 6(S)cell lithium polymer batteries in series connection. Please use same batteries in brand and capacity of 3000mAh or more. Please fully charge the batteries before use and make sure the voltage of each cell is all same.
- If the battery voltage is under 48V, the battery will be automatically charged if there is sufficient power generating capacity and the voltage will be recovered to 48V.
- The engine is to be started by built in starter, but if it necessary, it also can be started by an external starter.
- Periodical inspection after 50, 100 hours are necessary. Follow the maintenance manual, which is separately provided.

【ECU(Engine Control Unit)】

- The EC-23 is an engine control unit (ECU), which is 32-bit CPU-powered. It controls the engine based on the data of throttle opening, rpm, atmospheric pressure, induced air temperature, cylinder head temperature in the most suitable condition.
- For power supply 2 sets of 6 cell lipo ba as the battery voltage.
- The igniter's power is supplied by an isolated regulator inside the ECU, and you can turn on and off the igniter by sending a command to the ECU.
- ECU internal information such as engine RPM, cylinder head temperature, throttle opening, fuel pressure, voltage, electric consumption, electric power generation, the total fuel consumption, and etc. can be output to the outside of the ECU in real time by CAN and serial communication. By using Futaba S.BUS2 system, you can check the ECU internal information on transmitter.(*1)
- The EC23-LINK software, which enables to change the parameters and to monitor the data in real time in Windows® platform, is included as a standard accessory.

*1. Support will be available for the T16IZ SUPER and T26SZ after software updates.

*The specifications are subject to alteration for improvement without notice.

*Consult us for any questions on this product and return for repair.

*This instruction manual was created based on the product specifications as of December 2025.

2.Names of the parts

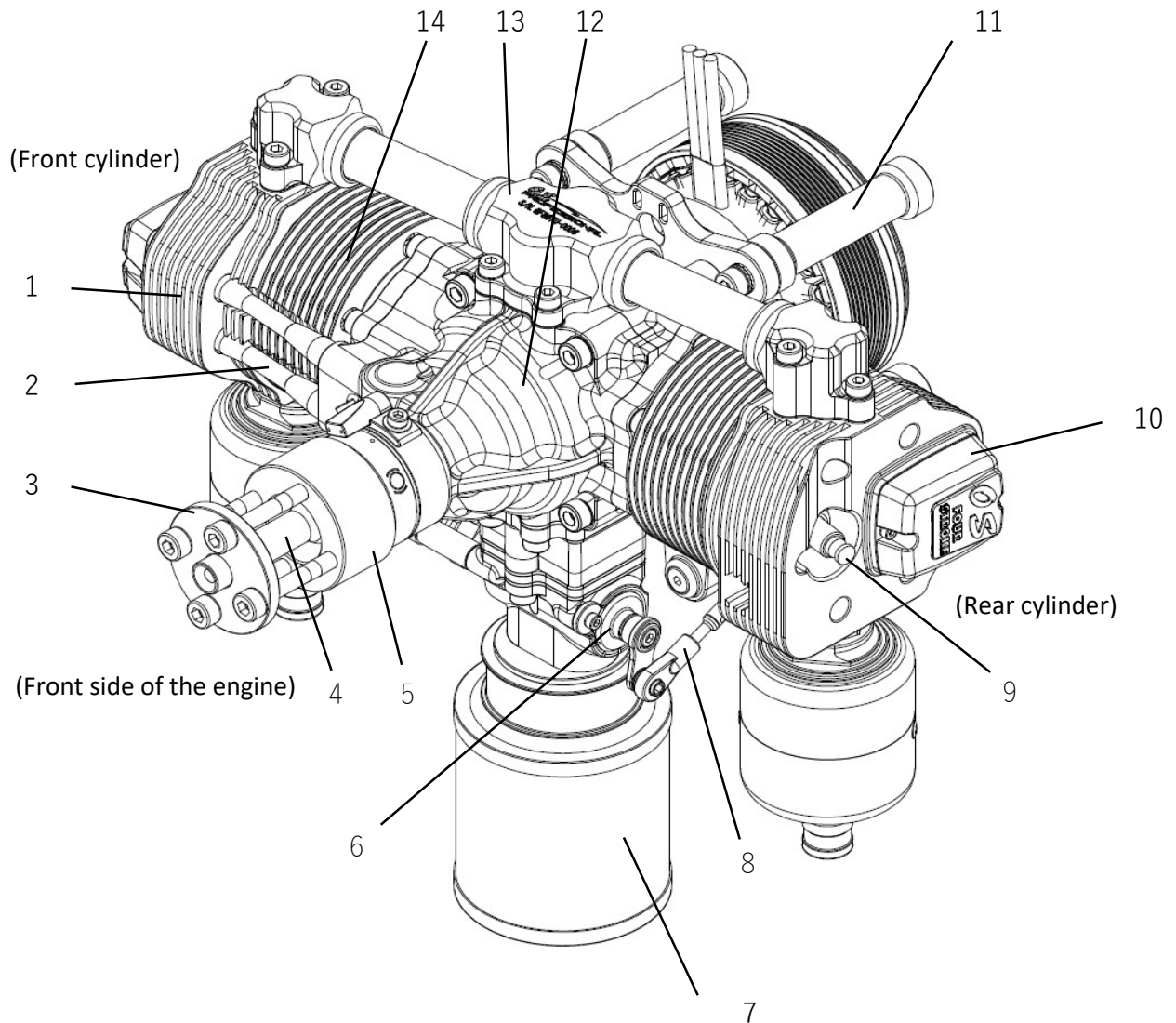

1. Cylinder head
2. Push rod cover
3. Propeller washer
4. Pilot shaft
5. Drive spacer
6. Throttle valve
7. Air cleaner
8. Throttle linkage rod
9. Spark plug (CM-6)
10. Rocker cover
11. Stand off engine mount
12. Crankcase (Front housing)
13. Intake manifold
14. Cylinder

2.Names of the parts

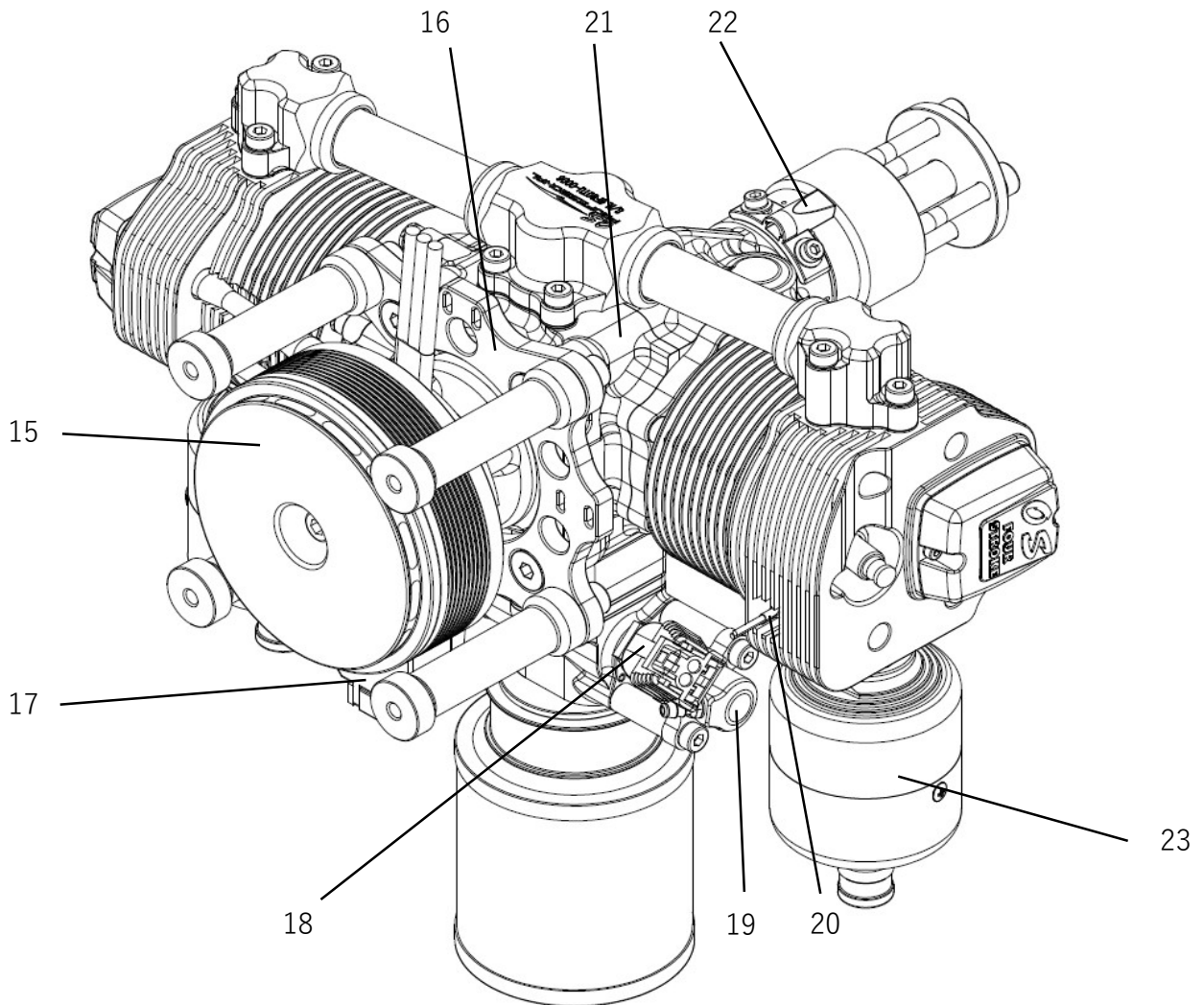

- 15. Starter generator motor (SGM-8020-185)
- 16. Mounting plate
- 17. Throttle servo
- 18. Injector & connector (Injector harness)
- 19. Injector coupler
- 20. Cylinder head temperature sensor
- 21. Crankcase (Rear housing)
- 22. Crankshaft rotation sensor
- 23. F-6051 Silencer

2.Names of the parts

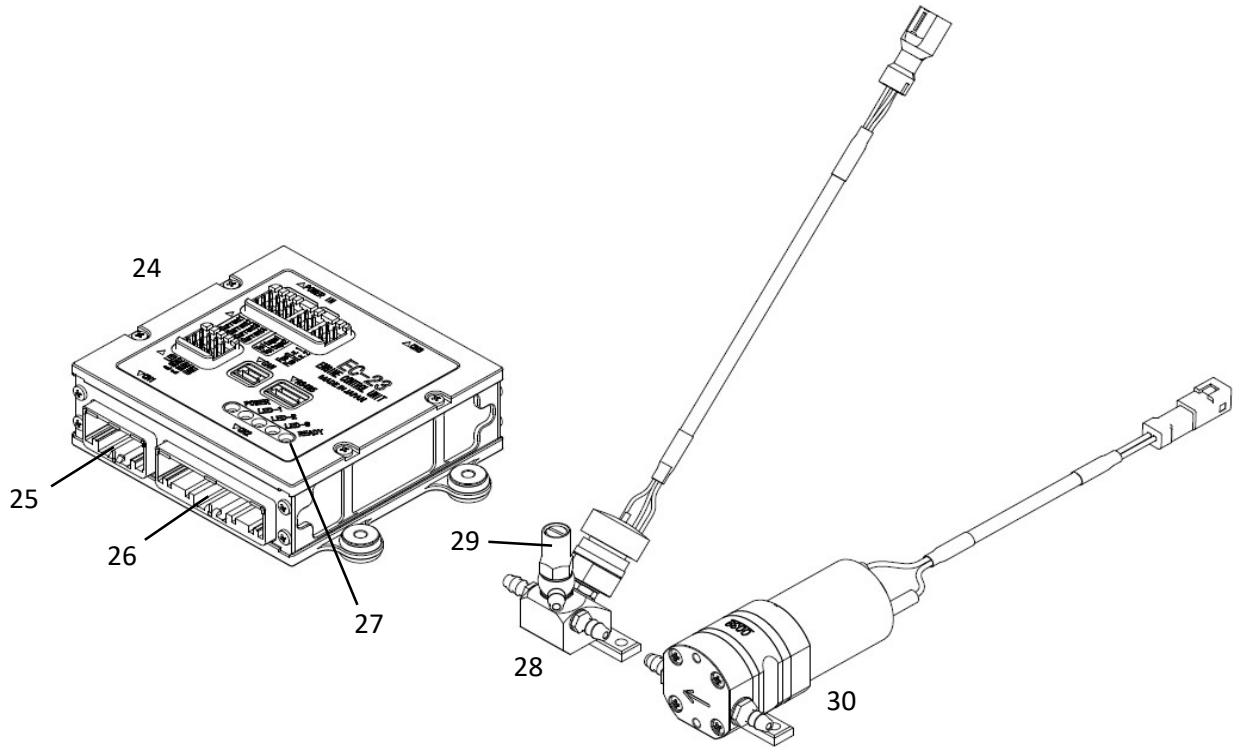

- 24. Engine control unit (ECU)
- 25. ECU connector [CN1]
- 26. ECU connector [CN2]
- 27. Status display LED
- 28. Fuel pressure sensor unit
- 29. Pressure release valve
- 30. Fuel pump unit

2.Names of the parts

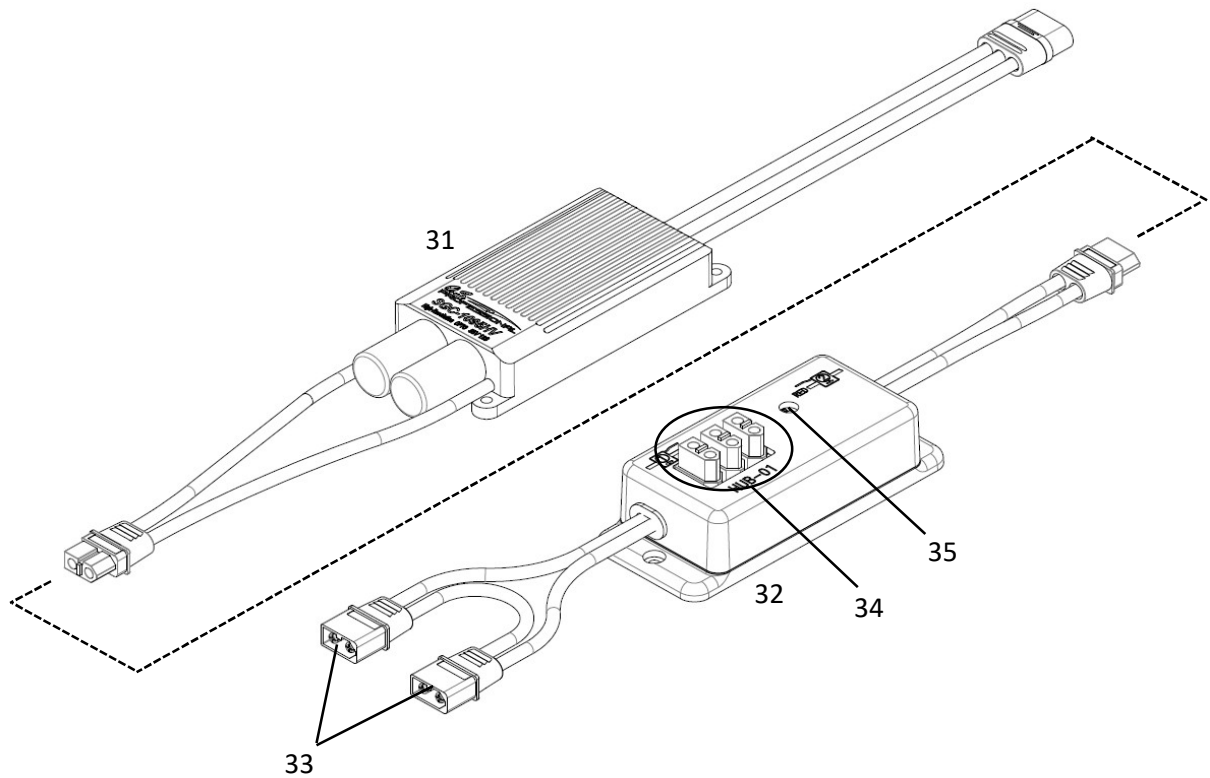

- 31. ESC for SGM (SGC-1095HV)
- 32. Power distribution box with a fuse (HUB-01)
- 33. TX60(M),Battery connectors(Two 6-cell Li-Po batteries connected in series)
- 34. TX60(F),Load connectors. (One of them is used for the ECU)
- 35. Fuse visual inspection window (*1)

*1:

When the fuse blows, it is suspected that SGC-1095HV or SGM-8020-185 has been short circuited. Do not use these products even after the fuse has been replaced.

3.Accessories



- 【ECU】 Model : IG-23**
• Engine Control Unit(ECU)



- 【ENGINE WIRING HARNESS】**
• Wiring harness that connect ECU and the engine.



- 【PWM signal harness】**
• It is used to input each signals of throttle, fuel trim, starter and ignition on/off by PWM signals from RC receiver, etc. It is not used when connecting to S.BUS or RS485.



- 【PUMP CONNECTION CORD】**
• Connect the ECU to the fuel pump and fuel pressure sensor unit.
• Install the fuel pump and fuel pressure sensor unit near the fuel tank.

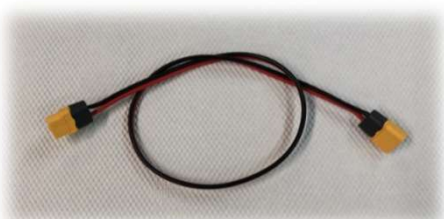

- 【ECU power cable】**
• Connect load connector from HUB-01 to ECU(RED+/BLACK-).
• The ECU measures the battery voltage from power supply voltage.
Always take the power from HUB-01's load connector.



- 【LED harness set】**
• Install to the ECU's LED connection terminal and use as an ignition pilot lamp.



- 【Power distribution box with a fuse】Model : HUB-01**
• Distribution box with a fuse for SGC.
• Connect two 6 cell li-po batteries with capacity of 3000mAh or more to 2 pieces of XT60(F). There is no balance charging function. Must use two batteries in same condition.
*For connection details, refer to the SGM(Starter Generator Motor) section in this manual.

3.Accessories



【Clamp type current sensor】 Model : SC-03 (2PCS)

- These are Clamp type current sensors.
- Clamp the HUB-01 case in the direction shown in the picture. Connect ① and ② to the ECU's CURRENT1 and CURRENT2 icons engraved on the case of the HUB-01 . It will not work properly if you connect the cable incorrectly. For connection details, refer to the SGM(Starter Generator Motor) section.



【SGC(ESC)】 Model : SGC-1095HV

- It is an ESC with a high withstand voltage specification with a controller for SGM.
 - The MR60 (M) connector connects to the SGM-8020.
 - The XT60 (F) connector connects to HUB-01.
- *For connection details, refer to the SGM(Starter Generator Motor) section.

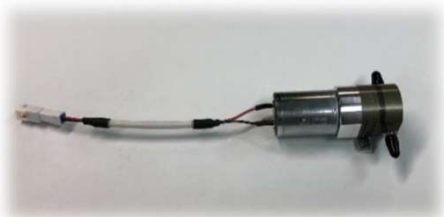

【FUEL PUMP UNIT】 Model: PM-02A

- Fuel is pumped from the tank.

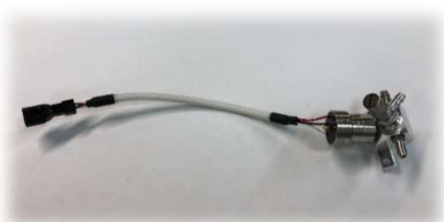

【FUEL PRESSURE SENSOR UNIT】 Model: SP-01

- Comes with a sensor that measures fuel pressure and a RELEASE VALVE that bleeds air.



【Igniter】 Model: IG-14

- Power for the igniter will come from the ECU.
- Connect the red connector to the Ignition signal in the ECU harness.



【Spark plug】 Model : NGK CM-6 (2PCS)

- Screw into the engine's cylinder head.
- The hexagon size is 14mm(Plug wrench is not included).
- Tightening torque is 12N•m



【Fuel filter】

- Inline fuel filter to be used between a fuel tank and a pump. The arrow mark shows the direction of fuel flow.
- * For details on how to use, see the section on mounting in the manual.

3.Accessories



【Non-bubble weight】

- Non-bubble weight to be used in a fuel tank to avoid air bubbles in fuel line.
- * For details on how to use, see the section on mounting in the manual.



【Hose clamp】 (6PCS)

- To be used to fix pressurized tubes to joints.



【FLUORINE (ETFE) RESIN TUBING】 (2m)

- Be sure to use this high pressure fuel tube for the fuel tube where positive pressure is applied.
- We also sell as parts.
Code No.28382303 FLUORINE(ETFE) RESIN TUBING (2m)



【F-6050 Silencer】 Model : F-6050 (2PCS)

- Compact silencer.



【Propeller washer & propeller hub bolts】

- To be used when a propeller is installed.



【ALUMINUM SPINNER】

- A type of spinner that is used by covering the propeller washer after installing the propeller.



【Connector lock】 (2PCS)

- For crankshaft rotation sensor and Ignition signal connector to prevent connectors from disconnecting.

3.Accessories



【Serial signal converter】 Model : U2S-2(for EC-2#)

•To be used to convert UART serial signal from ECU to USB serial signal when ECU is connected to a computer.



【Socket wrench (SST)】

•A special tool for attaching and detaching the temperature sensors. (intake air temperature sensor and cylinder head temperature sensor)
•Attach this tool to 1/4"(6.3mm) Socket wrench handle. (Socket wrench handle is not included in this set)

4. Standard screw tightening torque

■ Cap screw (Hex socket head bolts)

screw size	N·m
M2.6	1.1
M3.0	1.5
M4.0	3.6
M5.0	7.2

*However, some tightening points have specific torque instructions. The bolts with specific torque instructions are shown in the exploded view's parts list.

Standoff mount

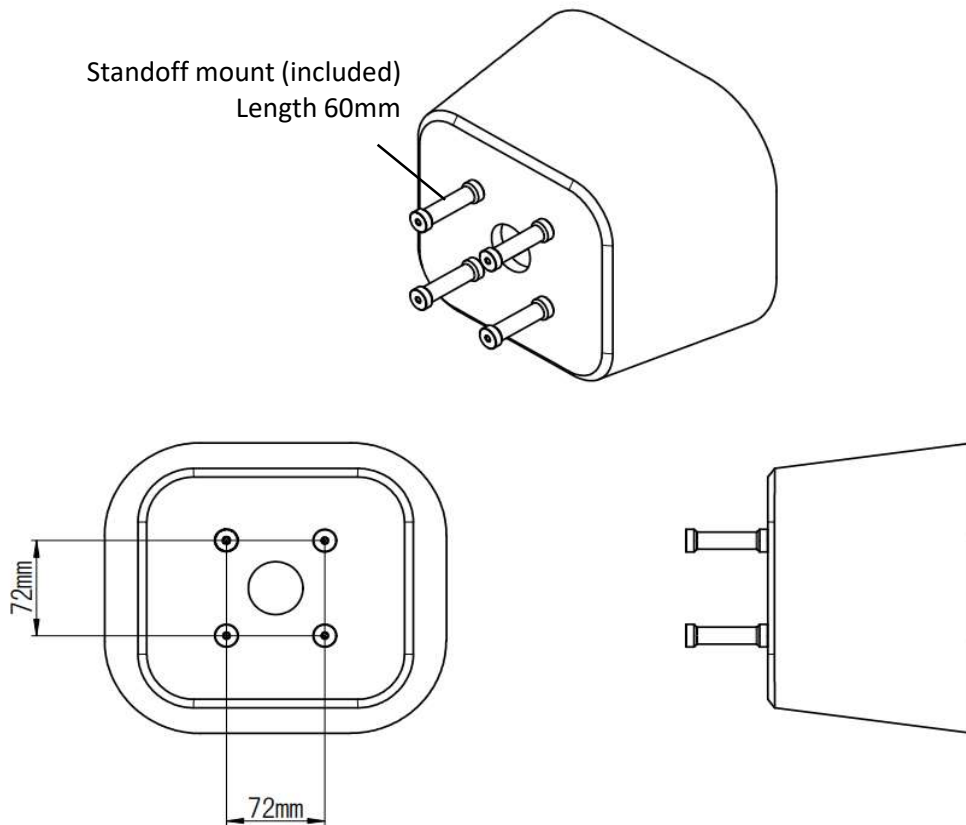

- Install the standoff engine mounts that come standard with the engine at a position of 72 mm x 72 mm.
- The length of the standard standoff engine mount is 60mm.

5. Installation

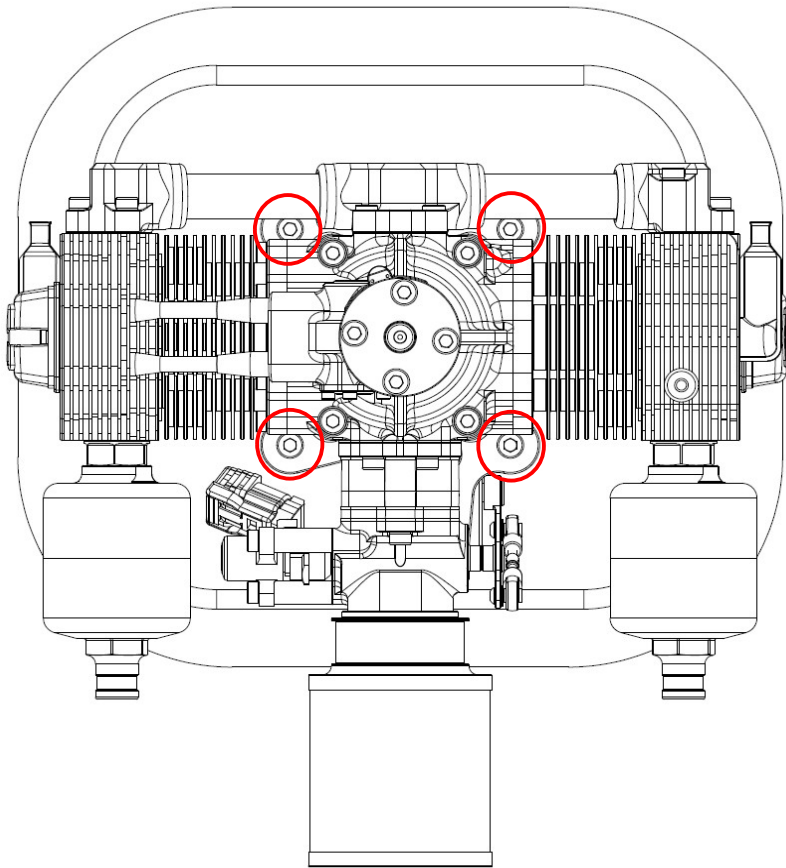

- Use M5 20mm length allen bolts to secure the engine to stand off engine mount.
- Please used Nord-Lock Washer to tighten 4 bolts.

(Nord-Lock Washer)

There is direction for stacking Nord-Lock washers.

As shown in the photo below, stack them so that the large wedge sides face each other.

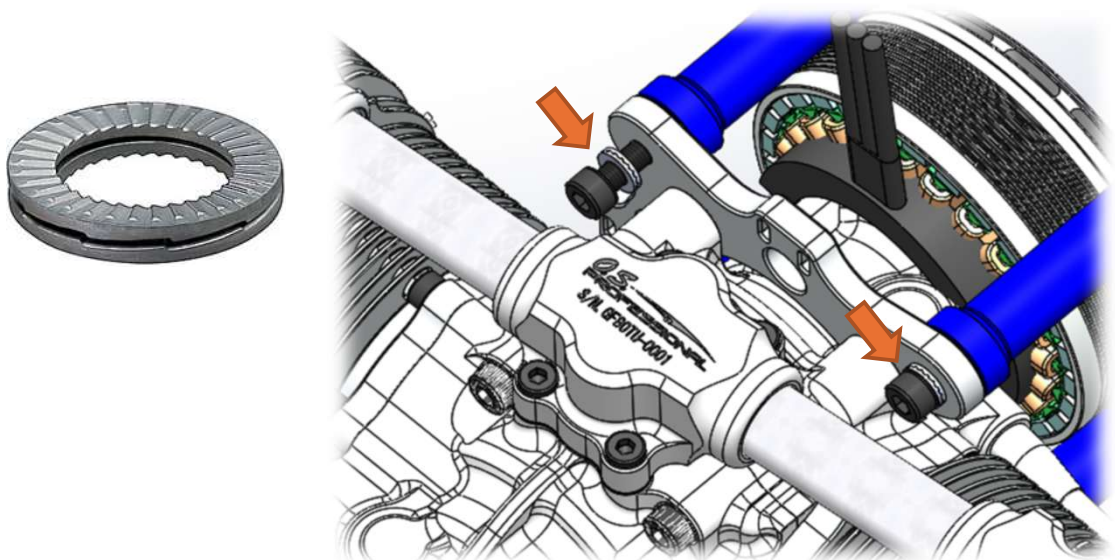

5. Installation

Fuel pump

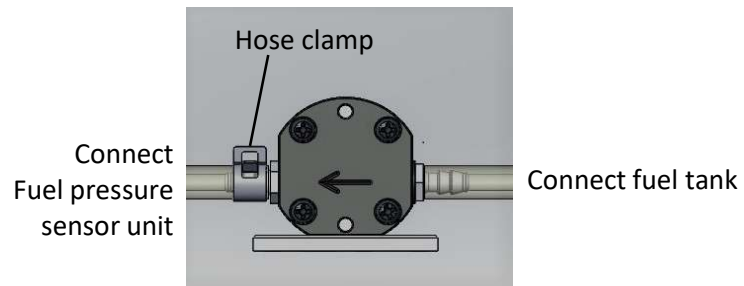

- The arrow mark shows the direction of fuel flow.
- Apply a hose clamp to the pressurized side of the hose.

CAUTION :

- A one-way valve is built in the fuel pump so pressure remains in the fuel line even after stopping the pump. Open the Pressure release valve to remove residual pressure.

5. Installation

Fuel pressure sensor unit

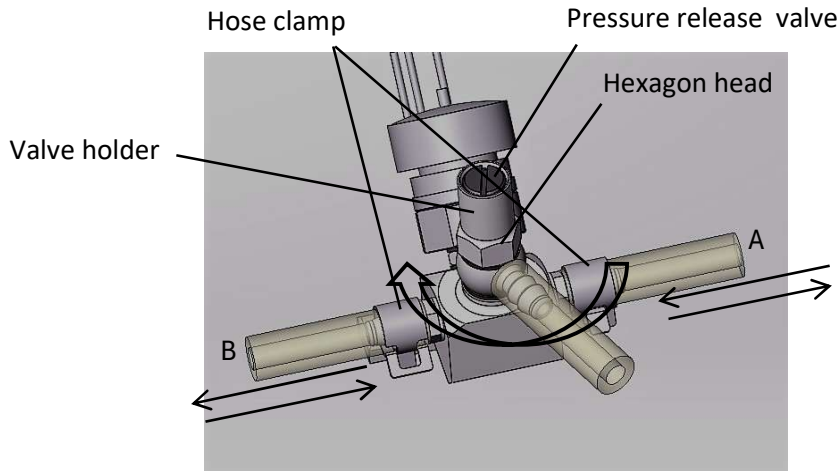

- The Pressure sensor works both from A to B and B to A. Decide the mounting direction according to your fuselage layout. Apply Hose clamps to both sides of the Pressure sensor.
- To change the direction of Pressure release valve nipple, loosen the Hexagon head with an 8mm wrench. Tighten the Hexagon head again after deciding the direction.
- If there are air bubbles in the tube between the fuel tank and the fuel pressure sensor unit after filling up the fuel tank, when the ECU switch is turned on for the first time, open the valve until the screw top becomes flush with edge of the valve holder as shown below. After eliminating the air bubbles, close the valve. Do not open the valve more than the flush position to avoid the pressurized fuel from coming out of the valve.
- Air bubbles between the Fuel pressure sensor unit and the engine (Injector) are of no concern as they do no harm since they are discharged through the Injector.

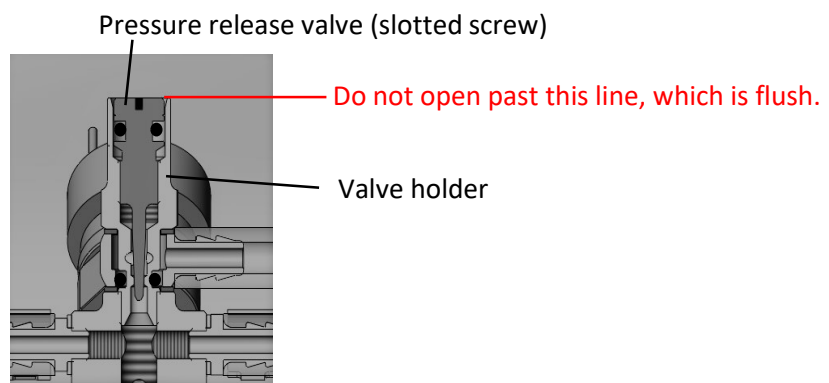

- Even if the the pump is off, there is residual pressure left in the fuel line. To prevent any accident, at the end of use for the day, release all the residual pressure by opening the pressure release valve.

5. Installation

Injector

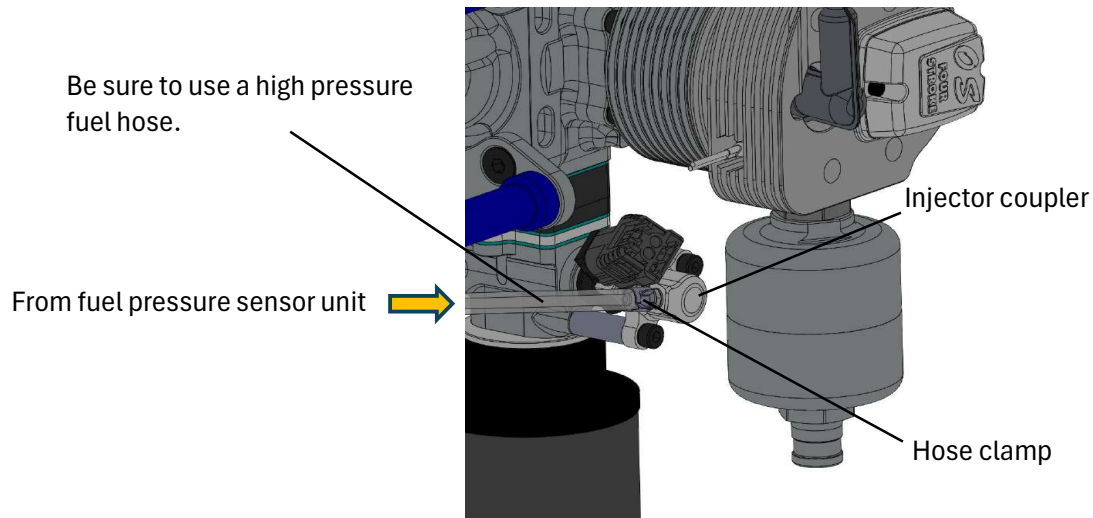

- Connect the tube from the Fuel pressure sensor unit to the Injector joint nipple. Use a Hose clamp. It is a must.
- Once a tube is connected to a nipple, an end of the tube is expanded and deformed. Cut the end when you use the same tube again.

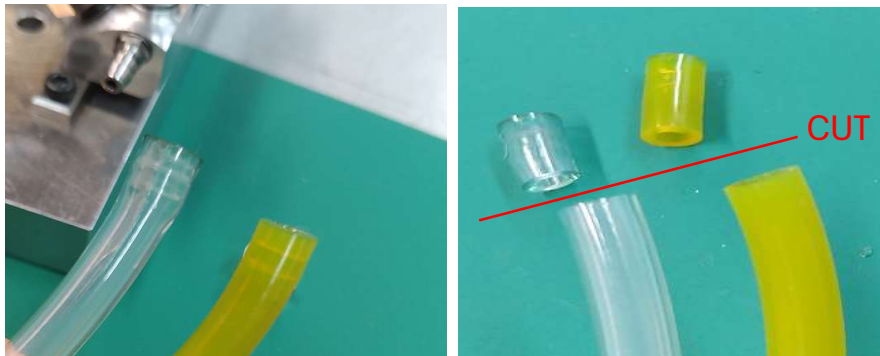

- Cut off an end of the tube when it is difficult to pull out from a nipple. Do not pull and twist the tube strongly to pull it out. Do not damage a nipple when you use a nipper or a knife to cut the end of the tube.

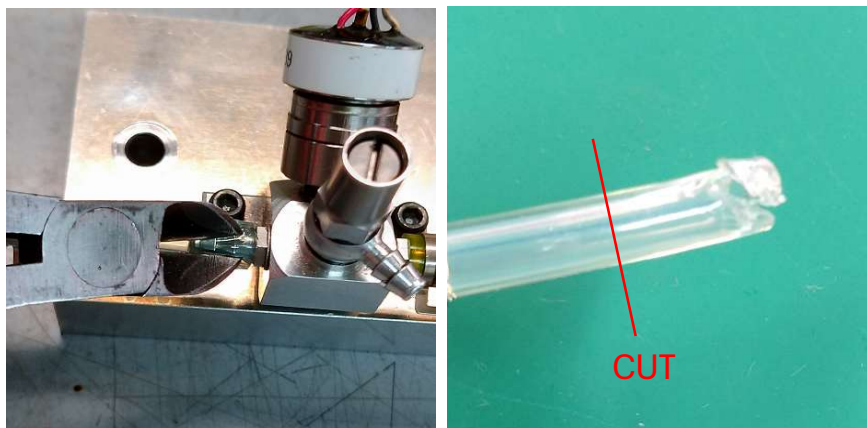

Silencer

F-6051 Silencer structure

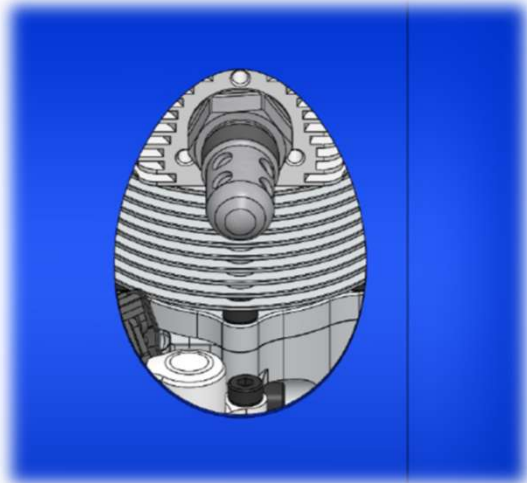
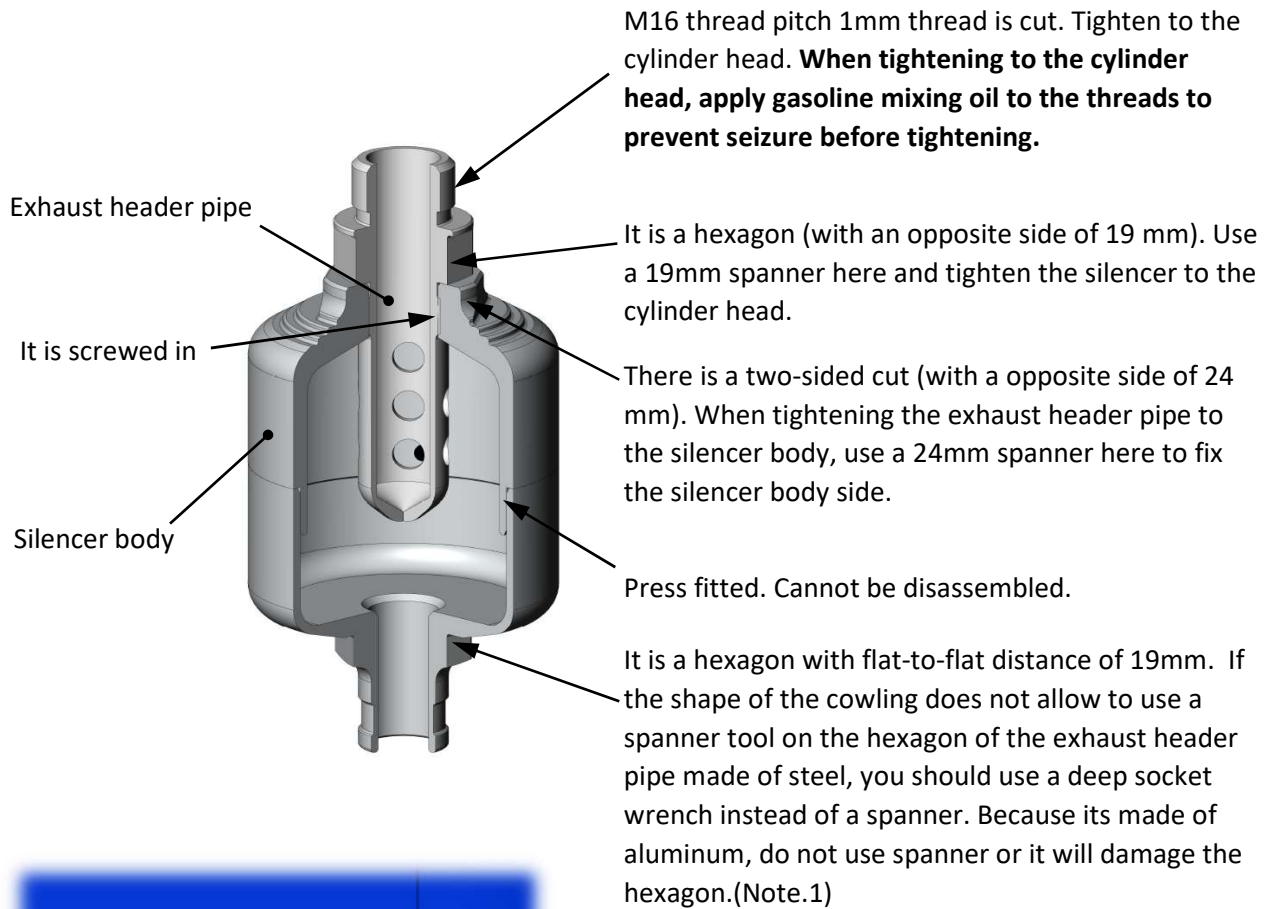

If the exhaust header pipe remains on the cylinder head side when you try to remove the silencer by hooking a tool on the silencer body, you can remove the exhaust header pipe using a 19 mm deep socket wrench.

On the contrary, when installing, the exhaust header pipe can be attached to the cylinder head first, and then the silencer body can be attached. (Note.1)

Note.1

This method is an exceptional usage in situations where a tool cannot be inserted. Basically, hang a tool on the hexagon of 19 mm on the opposite side of the exhaust header pipe to attach or detach the silencer. Also, please design the aircraft so that it can be done.

Propeller

- Please use a high quality propeller. We recommend to use one made of carbon fiber.
- Do not use a propeller that is slightly scratched or has a large impact even if it is not scratched.
- The size and shape of the propeller will be selected as the best one after actually flying, but first select it by referring to the following range. Engine's RPM rev limit is 8,000rpm due to the limitation of the generator's power generation voltage.

22x8-12 , 23x8-12 , 24x8-10 (diameter x pitch Inch)

- It is recommended to use a spinner. You can use the included aluminum spinner or a commercially available metal or resin spinner, but use a well-balanced and strong spinner.
- Imbalance of the propeller or spinner may cause vibration and damage the propeller or the aircraft. Be sure to use a well-balanced and strong enough propeller and spinner.
- Be sure to tighten the propeller mounting bolts via the propeller washers when mounting the propeller. Propeller mounting bolts are included, but if you use a propeller with a thin hub and the screws bottom out, or if you use a propeller with a thick hub and cannot screw it into the drive spacer sufficiently, refer to the table below to select the right bolts. Please replace them with certain steel hexagon socket head cap bolts.

Propeller hub thickness	Bolts
14~20mm	M5x35mm
18~24mm	M5x40mm (included)
22~30mm	M5x45mm

- Install the propeller before you use for the first time for the day and remove the propeller after done for the day.
- Check the appearance of the propeller mounting bolts every time, and replace them if they are scratched or rusted. Even if there is no abnormality in the appearance, replace them regularly (about 50 flights).

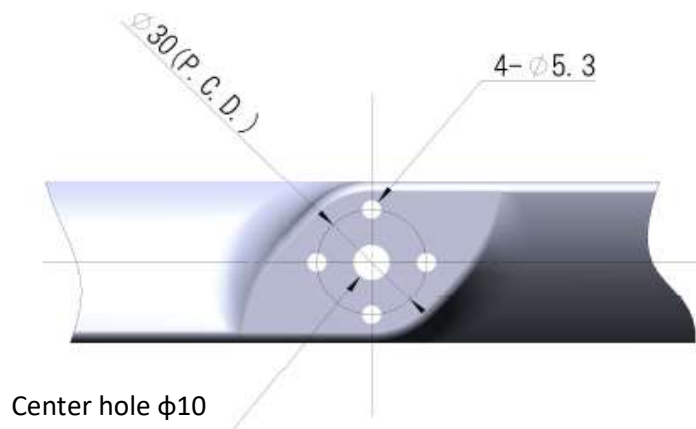

Propeller mounting hole dimensions

Plug cap

- Insert the plug cap as shown in Photo.1 by aligning it with the recess of the cylinder head. There are two plug cords from the igniter, but there is no distinction between the left and right cylinders.

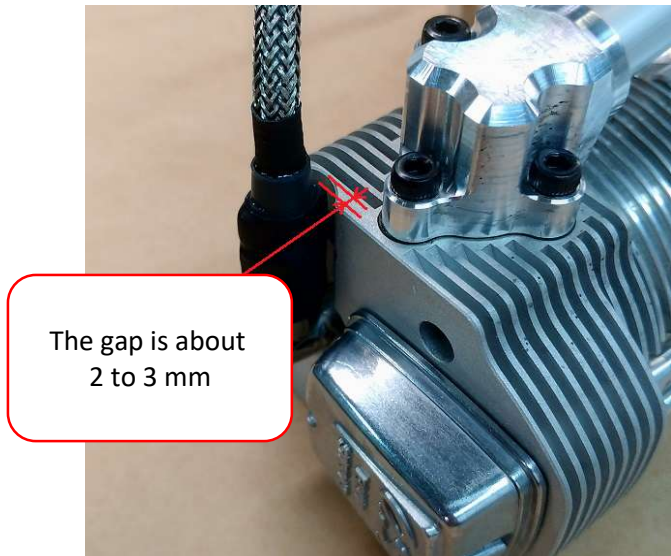

Photo.1

- To remove the plug cap, attach a commercially available nylon cable tie (repeat type with unlock) to the plug cap as shown in Photo.2, put your finger on it, and pull it while turning it toward the slope side of the recess of the cylinder head to remove it. (See Photo.3). If you remove the plug cap by hand, be sure to wear gloves to protect your hands. Immediately after the engine is stopped, the plug cap is also hot, so cool it down before proceeding.

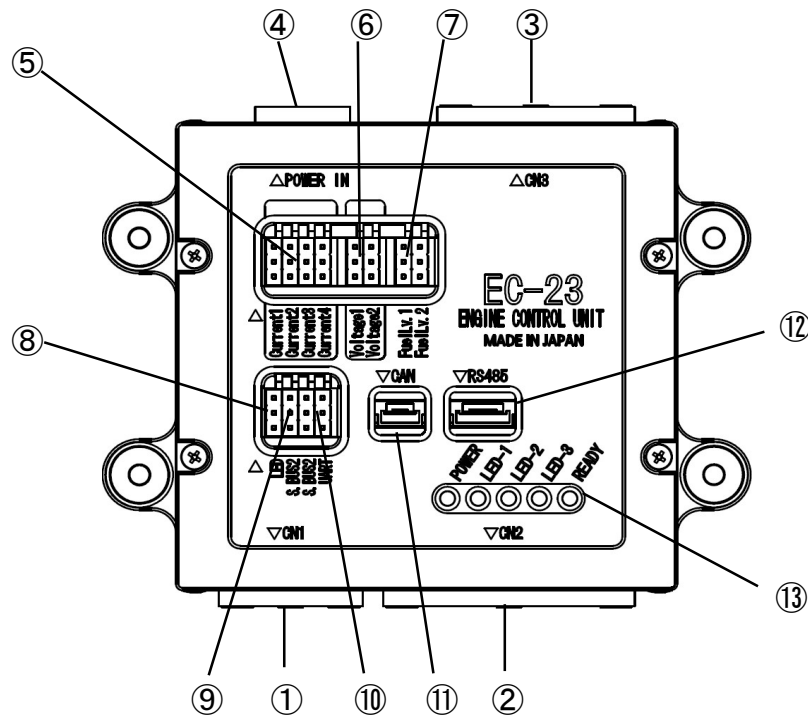

Photo.2



Photo.3

ECU



- ①【CN1】
Connect PMW signal harness.
- ②【CN2】
Connect engine wiring harness.
- ③【CN3】
Extension connector. Not to be used.
- ④【Power connection connector】XT60(M)
Use power cable and connect power supply connector to supply power.
- ⑤【Current sensor connection terminal】
Use CURRENT 1 and CURRENT 2. CURRENT 3 and CURRENT 4 are for optional SC-03 current sensor. By adding the SC-03 current sensor, it can measure up to $\pm 80A$ of DC current.
- ⑥【Voltage sensor connect terminal】
By connecting optional SV-01 Voltage sensor, it can measure up to DC100V of voltage.
- ⑦【Fuel sensor connect terminal】
By connecting optional SFL-01 fuel sensor, it can measure remaining fuel in the tank by measuring the height.
- ⑧【LED connect terminal】
By connecting the LED harness that is included, it will be used as a pilot lamp for ignition power.
- ⑨【S.BUS2 connect terminal】
Compliant terminal for FUTAB S.BUS2.
- ⑩【UART connect terminal】
UART serial communication terminal. Connect U2S-2 that is included.
- ⑪【CAN connect terminal】
CAN communication terminal.
- ⑫【RS485 connect terminal】
RS485 communication terminal.
- ⑬【ECU status display LED】
It shows the condition of ECU.

6.Engine control unit (ECU)

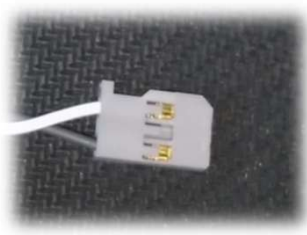
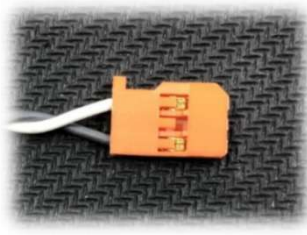
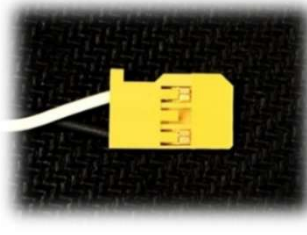
[A]	A-1	 Throttle signal input	<ul style="list-style-type: none"> Connect to a receiver or throttle signal cable from flight controller. <p>Specification PWM signal (*1)</p> <ul style="list-style-type: none"> Set the travel width so that the PWM signal width is 1100 μs or less on the throttle closed side and the PWM signal width is 1940 μs or more on the throttle opening side. <p>[W: Signal / B: GND] VIH=2.6V, VIL=0.4V, MAX5.5V</p>
	A-1	 Fuel trim signal input	<ul style="list-style-type: none"> If it is necessary to fuel adjustment from external device, connect it to the fuel adjustment signal from the receiver or flight controller. ECU controls quantity of fuel injection normally, so correction signal from the outside is not necessary. Leave it unconnected or connect 1520μs (neutral) PWM signal. When pulling out during operation, it holds the state just before. <p>Specification PWM signal: 1520μs (neutral) ±420μs (*1)</p> <p>PWM + →increase fuel supply. The range of increase and decrease is ±30%.</p> <p>[W: Signal / B: GND] VIH=2.6V, VIL=0.4V, MAX5.5V</p>
	A-1	 Starter signal input	<ul style="list-style-type: none"> Input the PWM signal from the external device such as transmitter, flight controller etc. to start the starter motor. The starter goes into standby mode when the PWM signal is 800 μs to 1400 μs. The PWM signal drives the starter at 1600 μs to 2200 μs. When ECU is started, if PWM signal is 1600μs or more, it will sound the alarm and stop functioning to prevent malfunction. <p>Specification PWM signal: 800μs~2200μs (*1)</p> <p>[W: Signal / B: GND] VIH=2.6V, VIL=0.4V, MAX5.5V</p>
	A-1	 IgnitionON/OFF signal input	<ul style="list-style-type: none"> Input the command signal to power on/off for igniter from the external device. If the PWM signal is between 800μs~1400μs, the igniter power switch is off (standby mode). When the PWM signal is between 1600μs~2200μs, the igniter will be powered on. When the ECU is started, if the PWM signal is not between 800 μs~1400μs, It will not turn on unless it is put into standby mode for 800μs to 1400μs. <p>Specification PWM signal: 800μs~2200μs (*1)</p> <p>[W: Signal / B: GND] VIH=2.6V, VIL=0.4V, MAX5.5V</p>

*1.The period of the PWM signal input to EC-23 should be 10 to 20 ms (50 to 100 Hz).

Wiring color

R	Red
W	White
B	Black

G	Green
Y	Yellow

6.Engine control unit (ECU)

《About connection via S.BUS》

- The ECU top side has 2 connecting terminals for FUTABA S.BUS2. One of them can be used to input the four signals listed on the previous page, such as the throttle signal, from a receiver or flight controller.+5V is supplied from the power pin. If connecting a device that does not require power supply, do not connect the power pin.
- By using S.BUS, the signal input to the ECU can be integrated to one wire, eliminating the need for the PWM signal harness on CN1.
- Selection of S.BUS connection and setting of each signal channel are done by EC23-LINK. For the setting method, refer to the EC23-LINK section.

《About connection via CAN》



- A CAN-compliant connector is provided on the top of the ECU. By using this connector, the four signals described in the previous page, such as the throttle signal, can be input from a flight controller etc. In this case, the CN1 PWM signal harness is not used.
- Selection of the CAN connection and channel settings for each signal are configured using EC23-LINK, which is described later. For the setting procedure, refer to the EC23-LINK section.
- For the pin assignment and communication protocol, refer to the Communication Protocol (CAN) section.

《About connection via RS-485》

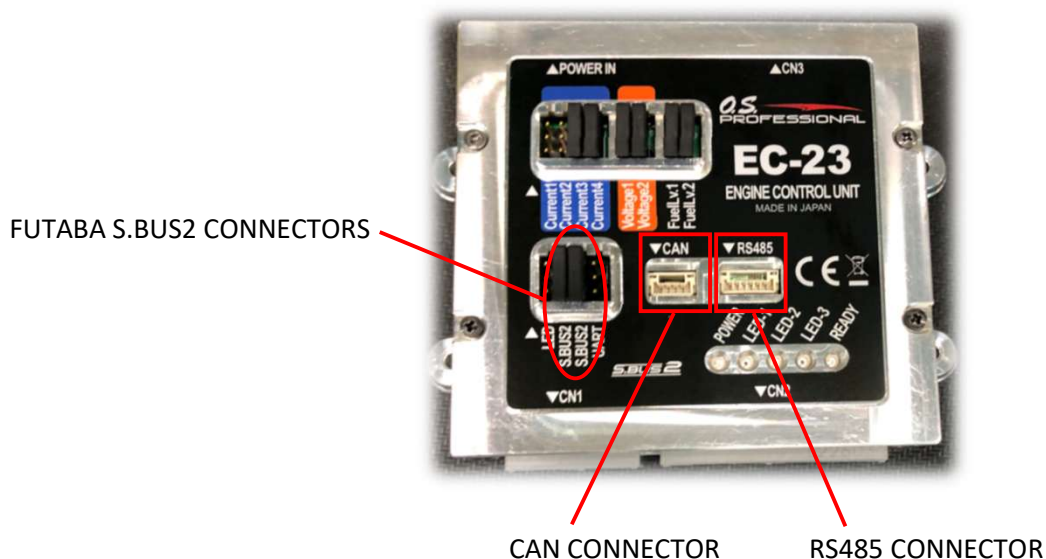
- The ECU top side has a connecting terminal for RS485. By connecting RS485, it will be able to input 4 signals that were explained in the previous page such as throttle signal, using a flight controller etc. By connecting this, CN1 signal harness will NOT be used.
- About selecting the connection and channel setting of each signal via RS485, refer to the EC23-LINK section.
- About pin assignment and communication protocol, refer to communicating protocol(RS485) section.

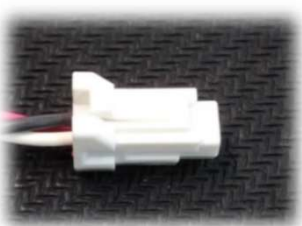

6.Engine control unit (ECU)

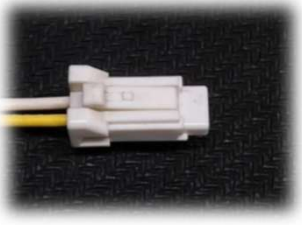
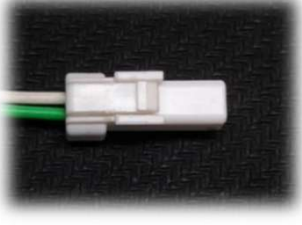
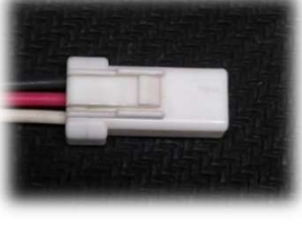

[B]	B-1	 Fuel pressure sensor	• Connect to Fuel pressure sensor via Pump connection cord. Specification Pressure sensor [R:DC+5V / W:Signal / B:GND]
	B-1	 Fuel pump	• Connect to Fuel pump via Pump connection cord. Specification [R:DC+12V / B:GND]
	B-2	 Cylinder head temperature sensor	• Connect to the temperature sensor of the cylinder head. Specification PT100 Platinum resistance thermometer [Y: No polarity / W: No polarity]
	B-2	 Injector	• Connect to Injector harness. Specification [W:DC+12V / G:GND (open-drain)]
	B-2	 Throttle servo	• Connect to Throttle servo. Specification PWM signal W:Signal / R:DC+5V / B:GND]

Wiring color

R	Red
W	White
B	Black

G	Green
Y	Yellow

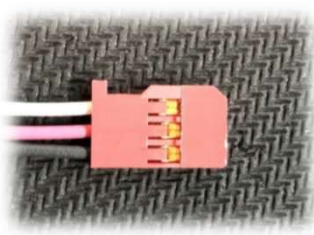
6.Engine control unit (ECU)

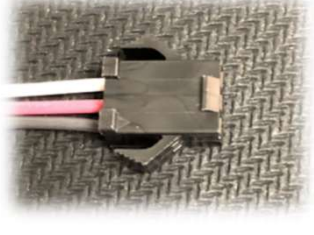
[B]	B-2	 Ignition signal	<ul style="list-style-type: none"> • Connect to the rotation signal input cable for the ignitor. • DC6V power that ECU need to send on/off command is supply to ignitor. <p>Specification</p> <p>[W: Signal / R: DC+6V / B: GND]</p>
	B-2	 Crankshaft rotation sensor	<ul style="list-style-type: none"> • Connect to Crankshaft rotation sensor. <p>Specification Hall-effect switch.</p> <p>[W: Signal / R: DC+5V / B: GND]</p>
	B-3	 SGC	<ul style="list-style-type: none"> • Connect to SGC-1095HV. <p>Specification PWM signal</p> <p>[W: Signal / R: DC+5V / B: GND]</p>





Wiring color

R	Red
W	White
B	Black

G	Green
Y	Yellow





7.Starter Generator Motor(SGM)

Connection

SGM-8020-185				
	<table border="1"><tr><td data-bbox="220 779 603 958"> SGM-8020-185</td><td data-bbox="603 779 1468 958"><ul style="list-style-type: none">· Connect to the MR60 (M) connector of the SGC-1095HV.</td></tr><tr><td colspan="2" data-bbox="603 958 1468 1064"><p>Specification connector : MR60(F) · 3-phase AC</p></td></tr></table>	 SGM-8020-185	<ul style="list-style-type: none">· Connect to the MR60 (M) connector of the SGC-1095HV.	<p>Specification connector : MR60(F) · 3-phase AC</p>
 SGM-8020-185	<ul style="list-style-type: none">· Connect to the MR60 (M) connector of the SGC-1095HV.			
<p>Specification connector : MR60(F) · 3-phase AC</p>				

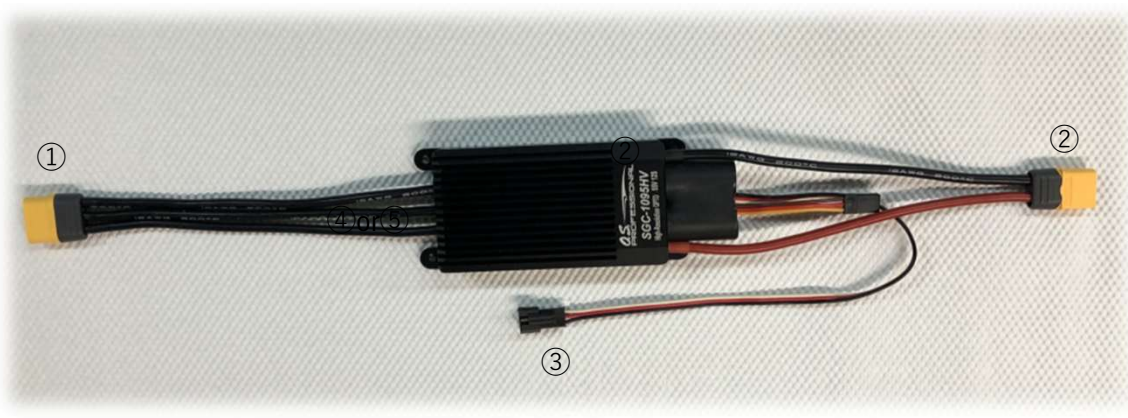
7.Starter Generator Motor(SGM)

Connection

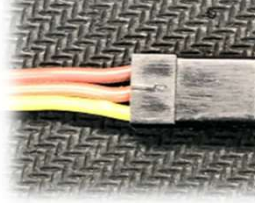
		
SGC-1095HV	 <p>①</p> <p style="text-align: center;">SGC-1095HV</p>	<ul style="list-style-type: none"> • Connect to the MR60 (F) connector of the SGM-8020 -185 <p>Specification connector: MR60(M)</p> <ul style="list-style-type: none"> • 3-phase AC
	 <p>②</p> <p style="text-align: center;">SGC-1095HV</p>	<ul style="list-style-type: none"> • Connect to the XT60 (F) connector of the HUB-01. <p>Specification connector: XT60(M)</p> <ul style="list-style-type: none"> • Power Input/Output
	 <p>③</p> <p style="text-align: center;">SGC-1095HV</p>	<ul style="list-style-type: none"> • Connect to the JST SM 3P (F) connector of engine wiring harness. <p>Specification connector: JST SM 3P(M)</p> <ul style="list-style-type: none"> • PWM <p>[W: Signal / R: DC+5V / B: GND]</p>
	 <p style="text-align: center;">SGC-1095HV</p>	<ul style="list-style-type: none"> • Not Used. <p>Specification</p> <ul style="list-style-type: none"> • Connector for factory settings.

7.Starter Generator Motor(SGM)

Connection

HUB-01	<p style="text-align: center;">④ HUB-01</p>	<ul style="list-style-type: none"> ▪ Battery connectors. ▪ Connect two 6 cell li-po batteries with capacity of 3000mAh or more to 2 pieces of XT60(F). ▪ There is no balance charging function. Must use two batteries in same condition. <p>Specification connector : XT60(M)</p> <ul style="list-style-type: none"> ▪ The two batteries are connected in series.
	<p style="text-align: center;">② HUB-01</p>	<ul style="list-style-type: none"> ▪ Connect to the XT60(M) connector of the SGC-1095HV. <p>Specification connector : XT60(F)</p>
	<p style="text-align: center;">HUB-01</p>	<ul style="list-style-type: none"> ▪ power supply connectors. ▪ All three connectors have the same specifications. ▪ Be sure to get power from one of these sources for the ECU. The voltage of battery is measured by checking the power supplied to the ECU. <p>Specification connector : XT60(F)</p>
<p style="text-align: center;">⑤ ECU power supply cable</p>	<p>If you install a power switch on the ECU, please install a switch with a capacity of 3A or more on this ECU power cord.</p> <p>Please be aware that even if the ECU is turned off, power will still be supplied to the SGC as long as the battery is connected.</p>	

7.Starter Generator Motor(SGM)

Connection

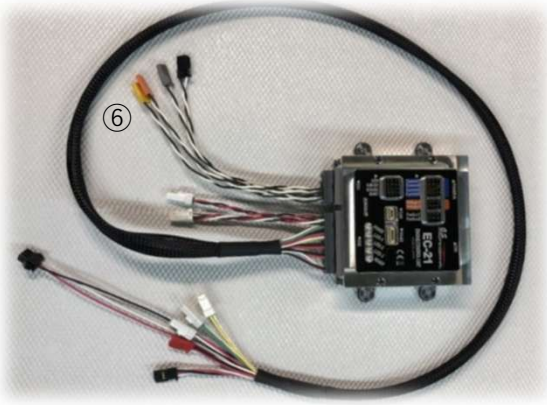
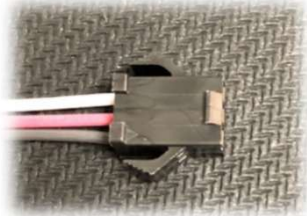
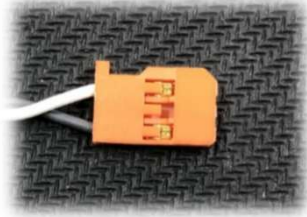
	
EC-23	<div style="display: flex; align-items: center;"> <div style="text-align: center; width: 150px;">  <p>EC-23</p> </div> <div style="margin-left: 20px;"> <ul style="list-style-type: none"> • Connect to the JST SM 3P(M) connector of the SGC-1095HV. <p>Specification connector: JST SM 3P(F)</p> <ul style="list-style-type: none"> • PWM signal <p>[W: Signal / R: DC+5V / B: GND]</p> </div> </div>
EC-23	<div style="display: flex; align-items: center;"> <div style="text-align: center; width: 150px;">  <p>EC-23</p> </div> <div style="margin-left: 20px;"> <ul style="list-style-type: none"> • Input the PWM signal from the external device such as transmitter, flight controller etc. to start the starter motor. (*1)(*2)(*3) • The starter goes into standby mode when the PWM signal is 800 μs to 1400 μs. • The PWM signal drives the starter at 1600 μs to 2200 μs. • When ECU is started, if PWM signal is 1600μs or more, it will sound the alarm and stop functioning to prevent malfunction. <p>Specification connector: FUTABA Servo Connector(F)</p> <p>[W: Signal / B: GND] VIH=2.6V, VIL=0.4V, MAX5.5V</p> </div> </div>



*1.Connection using FUTABA S.BUS is also possible. For information on connecting via S.BUS, please refer to the section "About connection via S.BUS".

*2.Connection using CAN is also possible. For information on connecting via CAN, please refer to the section "About connection via CAN".

*3.Connection using RS-485 is also possible. For information on connecting via RS-485, please refer to the section "About connection via RS-485".

7.Starter Generator Motor(SGM)

Connection

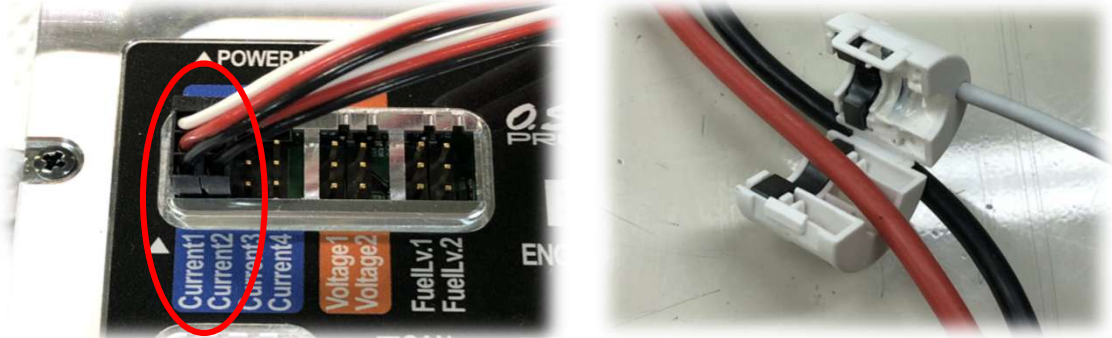
	
<p>⑦</p> <p>SC-03</p>	 <p>SC-03 (CURRENT1)</p> <ul style="list-style-type: none"> • Clamp one SC-03 to the red lead of the battery. • Please clamp in the direction shown in the illustration of HUB-01. • This is the [CURRENT1] sensor. • Connect this SC-03 connector (3P) to [CURRENT1] on the ECU.
<p>⑧</p> <p>SC-03</p>	 <p>SC-03 (CURRENT2)</p> <ul style="list-style-type: none"> • Clamp the other SC-03 to the red lead wire on the SGC side. • Please clamp in the direction shown in the illustration of HUB-01. • This is the [CURRENT2] sensor. • Connect this SC-03 connector (3P) to [CURRENT2] on the ECU.
 <ul style="list-style-type: none"> • Connect the connectors of each current sensor to the sensor terminals on the top of the ECU. • The current sensors can be opened by unlocking them. • The sensors that connect to [CURRENT1] and [CURRENT2] are identical but before initial use, connect the sensors to each channel and perform zero point calibration. • The corrected value of zero point calibration is memorized and remains undeleted in the ECU even the power is turned off. Once it is set, it doesn't need to be re-calibrated on every operation unless the sensor is replaced or the connected channel is changed. 	

Zero point calibration of current sensor

Before the initial start, the current sensors need zero point calibration connecting to each channel. The corrected value of zero point calibration is memorized and remains undeleted in the ECU even the power is turned off. Once it is set, it doesn't need to be re-calibrated on every operation unless the sensor is replaced or the connected channel is changed.

【Equipment you need】

PC with Windows® (10/11) and USB port

The included U2S-2 (serial signal converter)

EC23-Calibration (application software)

Power for the ECU (Connect HUB-01 and a power cord to the battery you are actually using.)

•The included U2S-2 (serial signal converter) uses an FTDI chip, the driver is registered in Windows® Update. Therefore, in internet environment, the driver is automatically downloaded and installed by connecting the USB serial converter to the PC. Install the driver in advance in an internet environment.

• For EC23-Calibration program, visit the URL below to go to download page.



URL

https://www.os-engines.co.jp/OS_professional/dll/index.html

【Installation of the software】

• Copy the EC23-Calibration_xxx.exe(xxxx:Version number) file to any file in the PC, then execute the file.

• When you intend to delete the software, just delete the EC23-Calibration_xxx.exe file.

【1】Connecting the U2S-2

• Connect the included U2S-2 3-pin connector to the UART connector on the top of the ECU.

• Connect the U2S-2 main unit to the USB port of the PC.



8.Zero point calibration of current sensor

【2】 Connecting Current sensors

- Connect current sensors to the ECU. Required current sensors are "CURRENT1" and "CURRENT2". "CURRENT3" and "CURRENT4" are optional.
- Do not clamp the lead wire with the current sensor during the zero point calibration. The current sensor clamps must be closed.

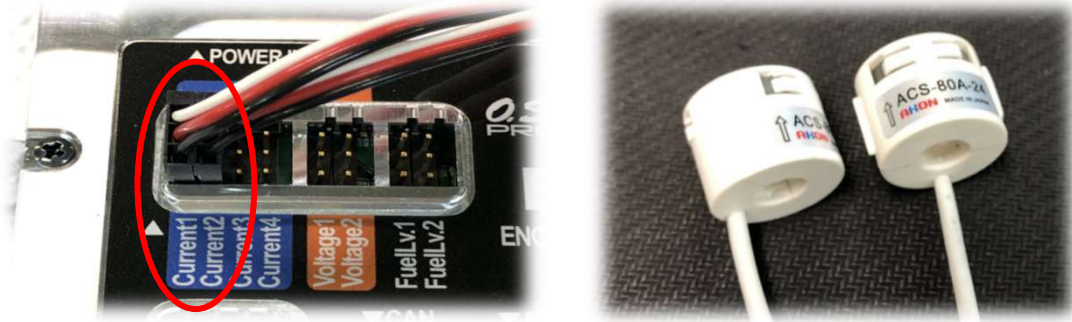

【3】 Turning of the ECU

- Turn on the ECU.

【4】 Starting up the software

- Execute the file EC23-Calibration_xxx.exe, which you copied to the PC. The following window will open.

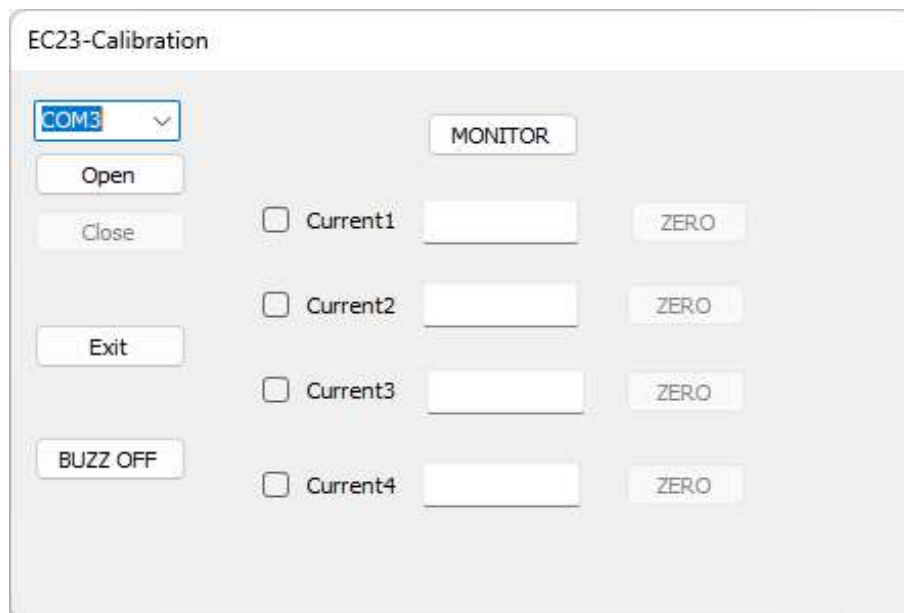

【5】 Confirmation of COM port assignment

- Check which COM port the serial connection to the ECU is assigned using Windows® device manager. Refer to the operation manual of the Windows®.
- In case the serial connection is assigned to other than COM1~ COM20, assign it manually to one of them. Refer to the operation manual of the Windows® how to assign a COM port number.

8.Zero point calibration of current sensor

【6】 Setting of a COM port number

• Select the same COM port you have assigned from the pull down menu. Then click [OPEN] and the connection is completed.

Select the same COM port number as you have confirmed by Device manager.

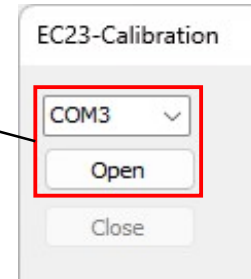

[Close] button

• For disconnecting a COM port connection. Do not click until you have finished using EC23-Calibration.

[Exit] button

• For exiting EC23-Calibration.

【7】 Zero point calibration

• Press [MONITOR] button. On default check boxes for Current1 and Current2 are checked showing the current value of each sensor. In case the optional Current3 and Current4 are connected, check the check boxes.

• With no lead wire clamped, the measurement should be 0.0A but if it shows differently, press ZERO button and make sure it shows 0.0A.

• This completes the procedures of Zero point calibration for current sensors. Press "Mon Stop" then "Close" button to close the port and then press "Exit" button to close EC23-Calibration.

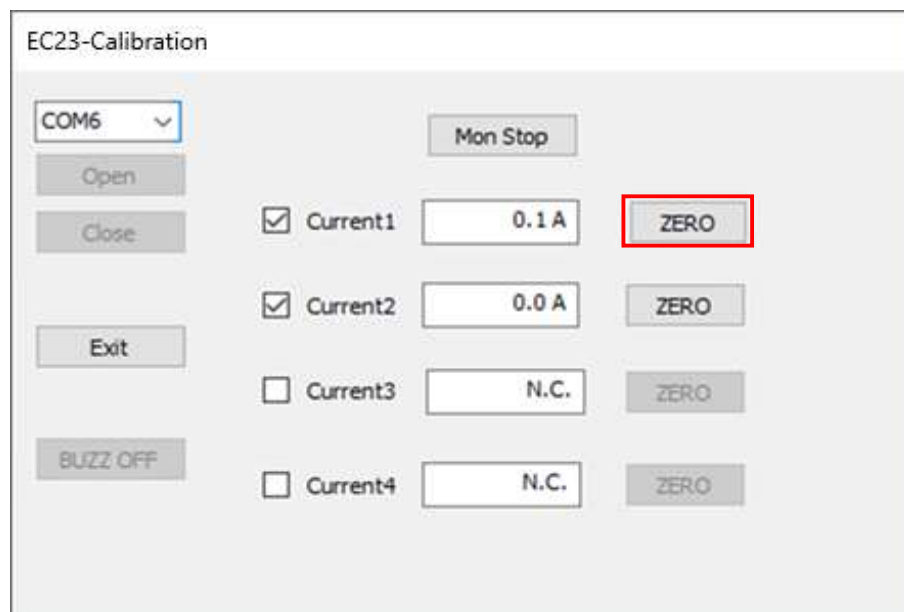

9.EC23-LINK

NOTE :

- Using EC23-LINK, you can monitor the parameter data in real time and change the parameters. After overhauling the engine, after disconnecting the throttle linkage, reset the throttle position using the EC23-LINK.

《Preliminary arrangements》

【Equipment you need】

- PC with Windows® (10/11) and USB port. The included U2S-2 (serial signal converter) uses an FTDI chip, the driver is registered in Windows® Update. Therefore, in internet environment, the driver is automatically downloaded and installed by connecting the USB serial converter to the PC. Install the driver in advance in an internet environment.

【Installing the Software on PC】

- EC23-LINK does not have an installation program. Copy the software file {EC23-LINK_xxx.exe} (xxx indicates the version name) to any location on your PC. After copying it, run {EC23-LINK_xxx.exe} directly.
- To remove the software, delete the {EC23-LINK_xxx.exe} file from your PC.

【Connecting】

- Connect the 3-pin connector of the supplied accessory U2S-2 to the UART connector on the top of the ECU.
- Connect the U2S-2 unit to the USB port of the PC.



- Connect the ECU to the engine.

- EC23-LINK can be activated without connecting any sensors to the ECU. For example, in teaching of throttle positions, you can activate the throttle servo as long as it is connected to the ECU.

CAUTION :

- Do not turn on the ECU when the fuel tank is empty. Operating the pump without fuel may damage the pump.
- In case you need to turn on the ECU without fuel supply, for example, to rewrite the settings by EC23-LINK, to deactivate the pump, disconnect the connector on the pump. Thirty seconds after disconnecting the connector, the buzzer rings alarming abnormality of fuel pressure, but you can stop it by clicking "BUZZ OFF" button in EC23-LINK display.

《Connecting to EC23-LINK》

【1】 Connecting the ECU to the engine

- Check the connectors of both the ECU and the engine.

【2】 Connecting the ECU to the PC

- Check the connection of the ECU and the PC.

【3】 Turning of the ECU

- Turn on the ECU.

【4】 Starting up the software

- Execute the file EC23-LINK_XXX.exe, which you copied to the PC. The following window will open.

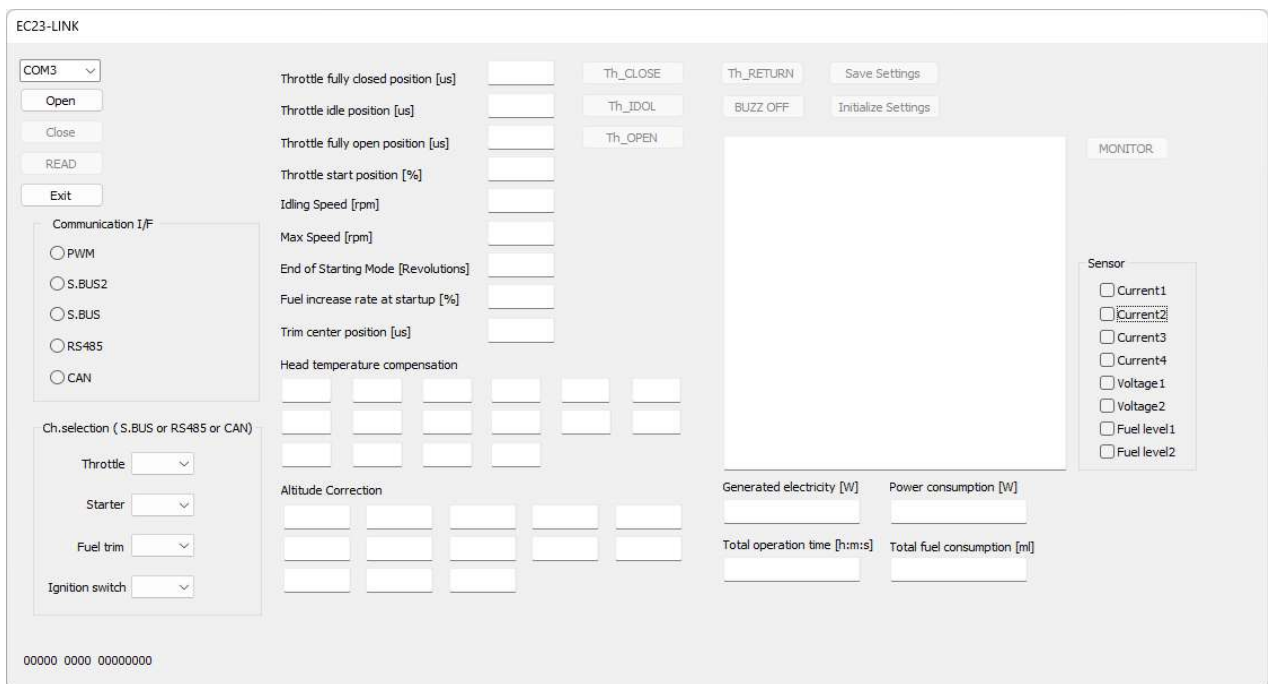

9.EC23-LINK

【5】 Confirmation of COM port assignment

• Check which COM port the serial connection to the ECU is assigned using Windows® device manager. Refer to the operation manual of the Windows®.

• In case the serial connection is assigned to other than COM1~ COM20, assign it manually to one of them. Refer to the operation manual of the Windows® how to assign a COM port number.

【6】 Setting of a COM port number

• Select the same COM port you have assigned from the pull down menu. Then click [OPEN] and the connection is completed.

Select the same COM port number as you have confirmed by Device manager.

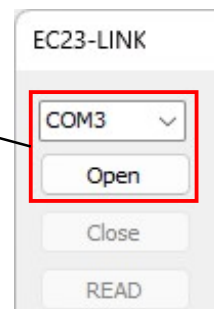

[Close] button

• For disconnecting a COM port connection. Do not click until you have finished using EC23-LINK.

[READ] button

• For reading the current setting value in the ECU.

[Exit] button

• For exiting EC23-LINK.

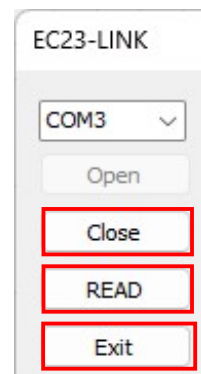

9.EC23-LINK

【ERROR MESSAGE】

•The following are error messages and what they mean.

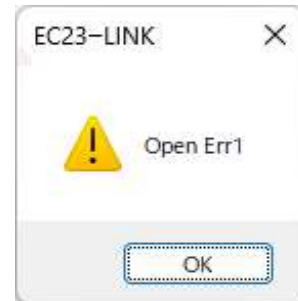

Open Err1	<ul style="list-style-type: none"> ① The serial port does not open. ② Check if the COM number of the serial port is correct. ③ Check the connection between the ECU and the PC.
RES TO	<ul style="list-style-type: none"> ① Response signals from EC-23 are not received. ② Check if the ECU is turned on and electric power is properly supplied. ③ Check the connection between the ECU and the PC.
Now Open	<ul style="list-style-type: none"> ① The serial port is open. ② Click [OK] button and continue the operation.
Open Err2	<ul style="list-style-type: none"> ① It failed to acquire the serial port settings from the PC. ② Check the connection between the ECU and the PC.
Open Err3	<ul style="list-style-type: none"> ① It failed the serial port setting in the PC. ② Check the connection between the ECU and the PC.
Open Err10	<ul style="list-style-type: none"> ① The serial port is still closed. Open the serial port.
RES SUM ERR	<ul style="list-style-type: none"> ① There is an error in the received data from the ECU. ② Check the connection between the ECU and the PC.

《Setting of the each value》

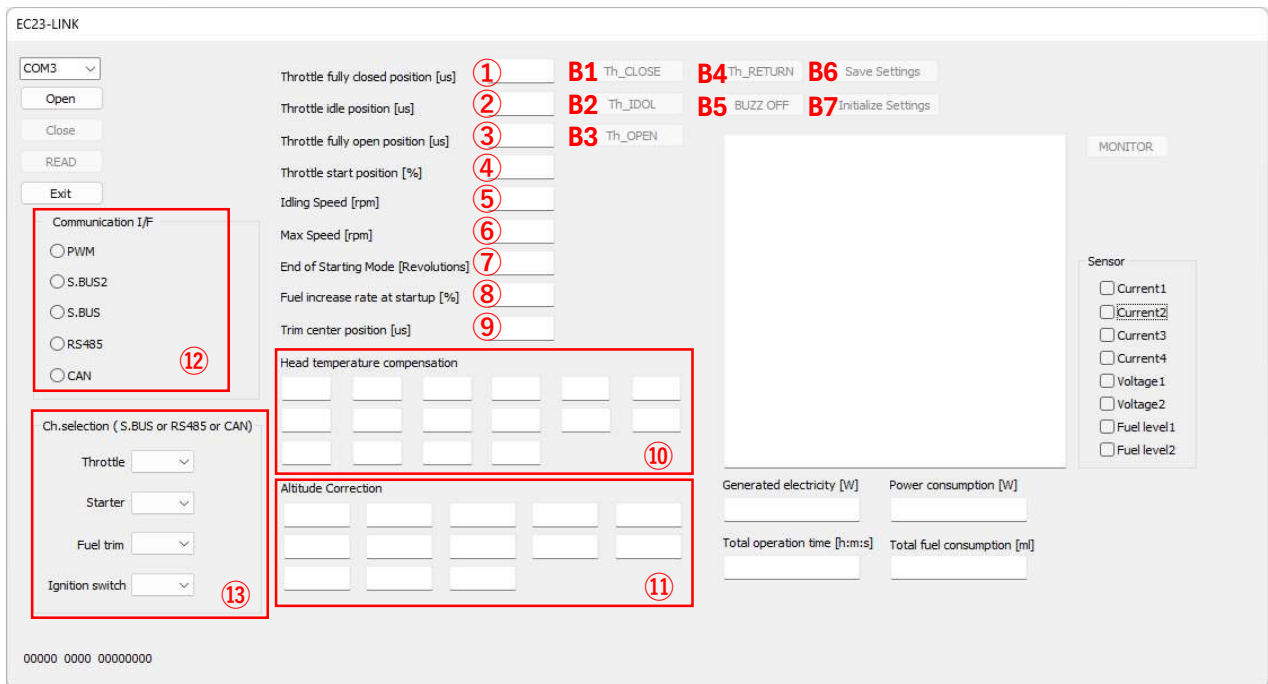

Input parameters in the edit boxes shown above (①~⑬), and click B6[Save Setting] to transfer the data to the ECU memory. ①~③ are for throttle servo settings (teaching). After inputting values in ①~③ and clicking B1 – B3, the throttle servo moves according to the input values. Please be careful about pinching such as fingers. **To return the operation of the throttle servo normal (control by throttle signals), click B4 [Th_RETURN] button (B4) or change the throttle signal.** You can initialize the settings by clicking B7 [Initialize Setting] button to return to the default settings, but when you initialize the settings, you need to set “Teaching processes” of throttle position again (setting items ①~③ below). After setting all the above parameters, you must always click [Save Settings] button (B6) to write the input data in the ECU memory into the flash memory. Turning off the ECU without doing so causes loss of all the input parameters.

【Setting Items】

① Throttle fully closed position [μs]

- Setting of the fully closed position by pulse width of PWM signal.
- The mark on the throttle valve aligns with the mark at fully closed position usually around 1150μs. Change the parameter to align each mark as shown on the left. (Larger value makes the throttle valve more open.)
- Inputting extremely small value may cause damage to the throttle servo creating excessive tension on the throttle linkage. So change the parameter ±10μs or less at each adjustment.

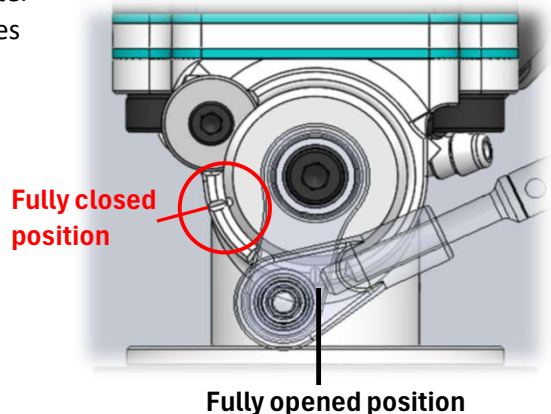

②Throttle idle position [us]

• Setting of the idling position by pulse width of PWM signal. The position of the throttle valve is usually +50μs(+40μs~+60μs) from the fully close position.

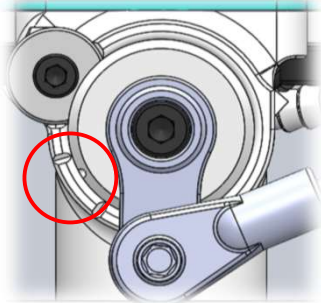

• This position, slightly open from the full close position is the reference position. The throttle valve is automatically controlled by the ECU to hold the idling rpm you have set when the throttle valve position is at idling position, in case you use a transmitter, the throttle stick of the transmitter is moved down to the bottom.

- In case the ECU could not hold the idling rpm and the engine stalls, add +5μs to the current parameter. When the aircraft is diving with the throttle control signal at the idling position, in case you use a transmitter, the throttle stick of the transmitter is moved down to the bottom, the propeller turns at higher rpm than the set rpm at idling by airflow to the propeller created by the dive. In this case, the ECU closes the throttle valve excessively until the engine stalls trying to reduce the propeller rpm. If it happens, add +5μs to the parameter also.
- In case the idling rpm doesn't decrease to the value you set in the process ⑤, even if temperature of the engine goes over 100°C, reduce the value by -5μs each time until the rpm decreases.

③Throttle full open position [μs]

• Setting of the full open position by pulse width of PWM signal.

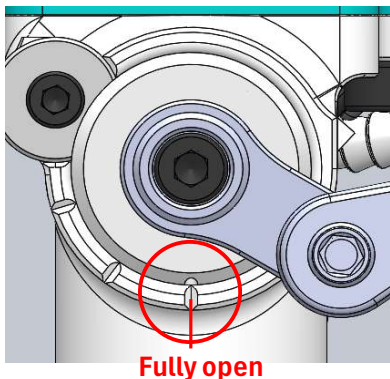

- The mark on the throttle valve aligns with the mark at full open position usually around 1870μs. Change the parameter to align each mark as shown on the left.
- Inputting extremely large value may cause damage to the throttle servo creating excessive tension on the throttle linkage. So change the parameter ±10μs or less at each adjustment.

④Throttle start position[%]

• Setting of the throttle valve position when you start the engine. To start the engine easier, the ECU opens the throttle valve at this position even throttle signal from your flight controller ordered to close more, in case you use transmitter, you move down the throttle stick of the transmitter and close the throttle valve more than this position. Parameter is to be set 0%~100%representing fully close to fully open with 0%~100%. The parameter is usually 20%.

⑤ Idling speed[rpm]

• Setting of the idling rpm when the throttle stick of the transmitter is moved down to the bottom, or throttle signal from your flight controller ordered the throttle valve to stay at idling position. The parameter varies depending on your propeller choice and an aircraft. Although the rpm at idling depends on propeller, the parameter is usually between 1600 and 2400 rpm. The ECU aim at the idling rpm you have set once the engine is warmed up. But the idling rpm is slightly higher than the set parameter when the engine is still cold.

⑥ Max Speed[rpm]

• Engine's maximum RPM needs to be set depending on the propeller you use. Because of the generator voltage limit, the maximum RPM for the engine is 8,000 RPM. Set the maximum RPM at 8,000RPM, and start the engine with the propeller you will be using and measure the maximum RPM. Input the maximum rpm to ECU. The ECU will regard this RPM as 100% and control the throttle so that RPM(thrust) corresponds to the % value(indicated value) of the throttle signal input. In other words, the required RPM (thrust) is maintained by opening the throttle to compensate for the drop in RPM caused by power load (power generation). The relation between throttle signal and RPM is calculated based on the theory that work by a propeller is proportional to the cube of its RPM.(Refer to Fig. 8.1)

NOTE:

- If actual throttle valve's angle is 90% or higher, power generation is stopped to prioritize propeller thrust.
- When the engine performance goes down due to heat soak and/or high altitude, it sometimes happens that it has not reached to the indicated RPM and not go any higher though the throttle is fully opened(100%) RPM . It can be used as it is but throttle may not respond in the high rpm range. This problem may be solved by setting the maximum RPM to lower value.

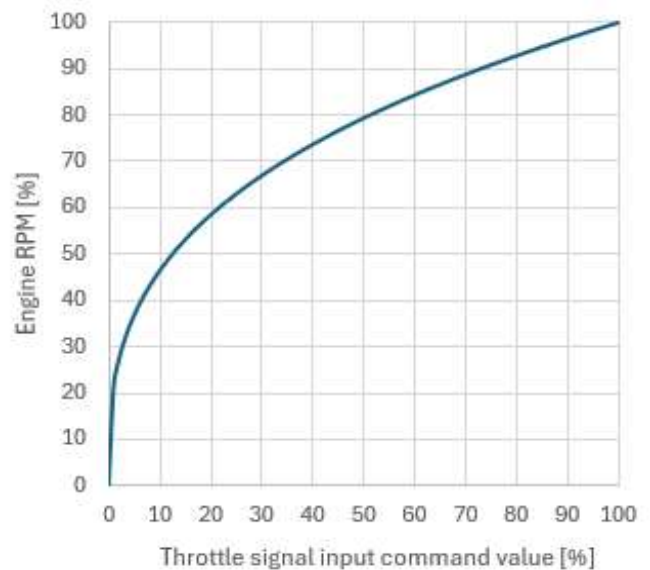

Fig.8.1

⑦ End of starting mode[revolutions]

• Setting the timing to exit from “ENGINE STARTING MODE”. The counting starts when engine rpm exceeds 960rpm. To enter the normal operating mode, input the parameter to decide at how many revolutions after reaching the 960rpm to exit from “ENGINE STARTING MODE” on the ECU. The parameter is usually 50 revolutions.

⑧ Fuel increase rate at startup [%]

• Set the amount of fuel injected at engine start. The parameter shows how much percentage (%) of fuel is to be added to the basic fuel injection. Usually the parameter is 100%. If the parameter is 100%, 200% of the basic injection amount of fuel will be injected.

⑨ Trim center position[us]

Setting of the central parameter (neutral) of Fuel increase/decrease adjustment signal (PWM). Set the parameter according to a receiver or flight controller you use. The pulse width parameter input here is the neutral position. Fuel increases/decreases $\pm 30\%$ in the range of $\pm 420\mu s$. Positive (+) side increases fuel injection and negative (-) side decreases. The default setting is $1520\mu s$, which is the neutral position of Futaba receiver.

⑩ Head temperature compensation

• Increasing fuel injection according to the rise of Cylinder Head temperature (CHT).

This is the function to stabilize engine operation at low temperature and prevent the engine from overheating at high temperature. The parameter can be input at 16 points, by $20^\circ C$ interval between $0\sim 300^\circ C$. The parameter shows how much extra fuel is added to the basic fuel injection by percentage (%). The temperature between the points is complemented by the lower and higher points. The parameter at $0^\circ C$ is applied to below $0^\circ C$, and the one at $300^\circ C$ is applied to more than $300^\circ C$. Use the default settings in an ordinary case.

• It has up to $300^\circ C$ of correction data but that does not mean it can be used up to $300^\circ C$. If the cylinder head temperature goes over $240^\circ C$ at any moment, please take measures to allow the engine to get more air to cool down. The ideal temperature range is from $160^\circ C$ to $220^\circ C$.

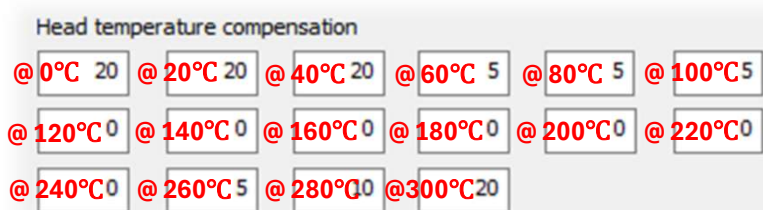

⑪ Altitude correction

• Increase/decrease fuel injection according to altitude. The parameter can be input at 13 points by 500m interval from $-1000\sim 5000m$. The parameter shows how much extra fuel is added to the basic fuel injection by percentage (%). The altitude between the points is complemented by the lower and higher points. The parameter at $-1000m$ is applied to below $-1000m$, and the one at $5000m$ is applied to more than $5000m$. Use the default settings in an ordinary case.

• It has between $-1000m$ to $5000m$ of correction data but that does not mean it can be used in such high altitude range. The engine is designed to be used in the range between $0m$ to $3000m$ altitude.

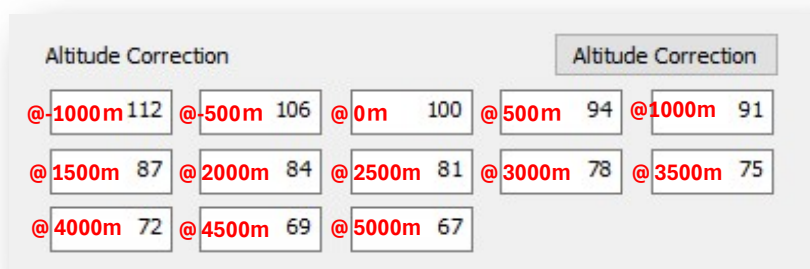

⑫Communication I/F

Select the interface for sending commands to the ECU. Default is PWM.

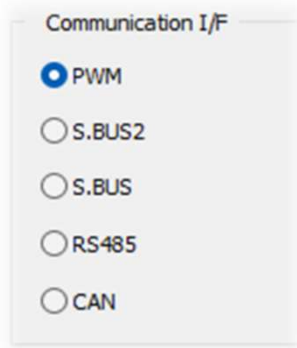

- PWM
Select this when sending commands to the ECU using the PWM signals connected to the PWM signal harness(CN1).
- S.BUS2
Select this when sending commands to the ECU using the S.BUS2 signals after connecting to the S.BUS2 connector. Select this if you are using S.BUS2 which uses the telemetry function.
- S.BUS
Select this when sending commands to the ECU using the S.BUS signals after connecting to the S.BUS2 connector. Select this if you are using S.BUS which does not use the telemetry function.
- RS485
Select this when sending commands to the ECU using serial signals after connecting to the RS485 connector.
- CAN
Select this when sending commands to the ECU using CAN communication after connecting to the CAN connector.

⑬Ch. selection(S.BUS2 or RS485)

In ⑫ if S.BUS or RS485 is selected, set the channels for each signal: Throttle signal input, Starter signal input, Fuel trim signal input and Ignition ON/OFF signal input.

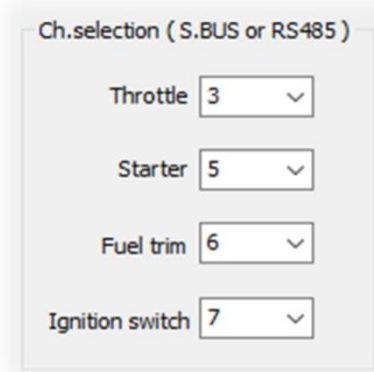

Ch.selection (S.BUS or RS485)

Throttle	3	▼
Starter	5	▼
Fuel trim	6	▼
Ignition switch	7	▼

When selecting, you can set one channel from 1 to 24.

CAUTION :

- At the end of setting, make sure you press B6[Save Setting] and save it to the ECU memory or else it will be all erased.
- in setting items ①~③ contains teaching mode for throttle position.
- If its not needed, do not change setting items ①~③ and ⑤~⑥ or engine might run poorly.
- Input side of throttle signal's setting(amount of travel, end-point setting)is used with《MONITOR》 funtion.

《MONITOR》

• Press [MONITOR] button with the ECU connected to the PC, and you can monitor the updated information in the ECU. To exit the MONITOR mode, click [Mon Stop] button.
 ([MONITOR] button is switched to [Mon Stop] during the MONITOR mode).

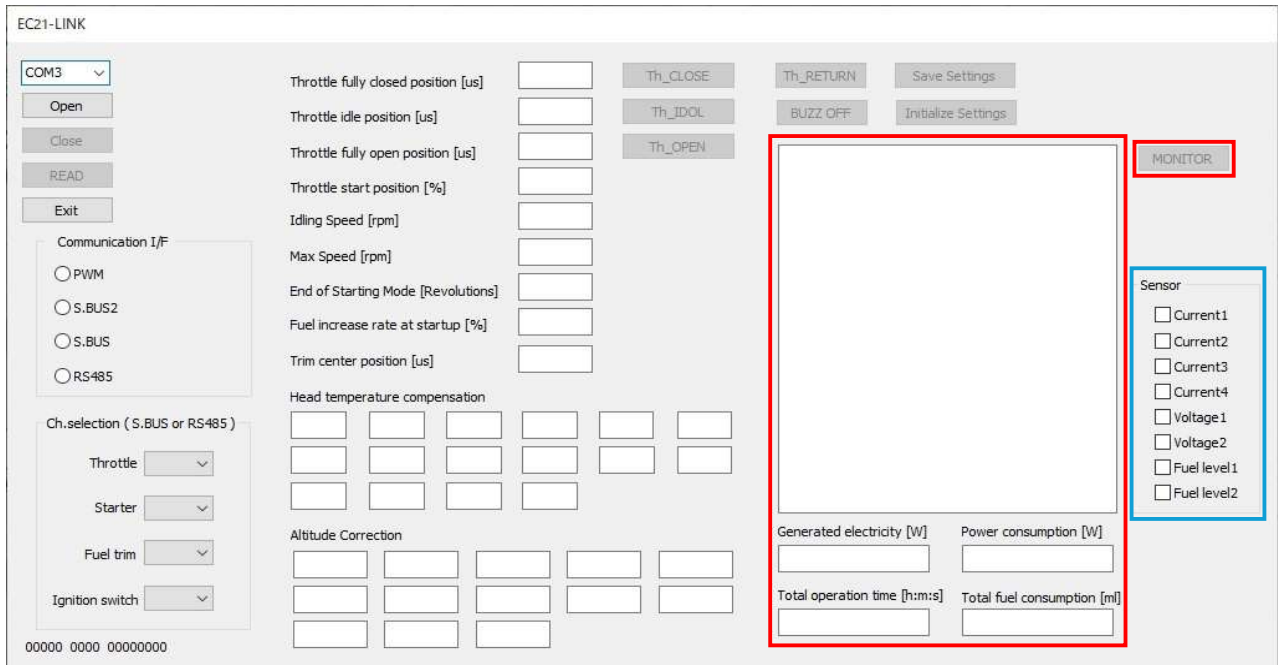

Fig.8.2

【Information shown during the MONITOR mode】

(1) Pressure (hPa)

Atmospheric pressure measured by the sensor in the ECU.

(2) Fuel pressure (kPa)

Fuel pressure after the fuel pump.

(3) Power supply voltage (V)

Voltage of the power line supplied to the ECU. (Battery voltage)

(4) 3.3V voltage (mV)

Voltage of the 3.3V power supply line of the ECU.

(5) 5V voltage (mV)

Voltage of 5v power source line in the ECU.

(6) 12V voltage (mV)

Voltage of the 12V power supply line of the ECU.

(7) Head temperature (°C)

Temperature measured by the temp. sensor in the cylinder heads.

(8) Throttle signal input (%)

Throttle position (0 - 100%) controlled by throttle signals from a RC receiver or a flight controller.

NOTE:

- throttle positions are affected by the settings of the throttle servo. After teaching of the throttle positions, adjust the travel amount (end point) of throttle signal input from the receiver or the flight controller referring to the value on the monitor.
- The end points of throttle fully open and fully closed positions are to be set 0% and 100%, or -1% and 101% with some tolerance. (signals 0% or less and 100% or more are recognized as 0% and 100% respectively.)

(9) Throttle signal output (%)

The signal output to the throttle servo; how much throttle is open, is shown as 0% through 100%.

(10) Trim signal Width (μ s)

Input value (the width of PWM signal) of the fuel adjustment correction from a receiver or a flight controller.

(11) Rotation speed (rpm)

Revolutions of the engine per minute.

(12) Fuel consumption [ml]

After the ECU is powered on, it will display fuel consumption. There may be some discrepancy from the actual consumption because it is calculated from how long the fuel injected from the injector. The value will be reset when the ECU is turned off.

(13) Operating time [h:m:s]

When the ECU is turned on, display will show the operating time. Operating time will not be counted when engine is off. Operating time will be reset when the ECU is turned off.

(Sensor measurement)

The measured value of the following articles (13)~(17) are shown on the display when the sensors are connected to the connection terminal on top of the ECU. (13)Current 1 and (14)Current 2 have to be connected for power generation control. Everything else is optional. In Fig 8.2, in the blue box, by putting a check on check boxes, you can select an item, which can be shown on the display.

(14) Current1 (Battery charging) [A]

It's the value of the current sensor, which is connected to the Current 1's connection sensor, and is measuring the battery current. Its positive when the battery is charged and negative when the battery is discharged.

(15) Current2 (Power generation) [A]

It's the value of the current sensor, which is connected to the Current 2's connection sensor, and is measuring the current of the SGC. Its positive during the power generation and negative when the starter motor is driven.

9.EC23-LINK

(16) Current3 [A], Current4 [A]

When an optional SC-03 current sensor is connected to Current 3 or Current 4's connection terminal, the DC current up to $\pm 80\text{A}$ can be measured and monitored.

(17) Voltage1 [V], Voltage2 [V]

By connecting an optional SV-01 power sensor to the connect terminal of Voltage 1 or Voltage 2, the voltage up to DC100V can be monitored.

(18) Fuel level1 [%], Fuel level2 [%]

By connecting an optional SFL-01 fuel sensor to the connect terminal of FuelLv.1 or FuelLv.2, the remaining fuel(by measuring the height of fuel in the tank) can be monitored.

(19) Generated electricity[W]

It shows the generated power by SGM.

(20) Power consumption[W]

It shows the power consumption from the power supply connectors of HUB-01.

(21)Total operation time[h:m:s]

It shows the total operating time from the factory delivery. When engine is off, operating time is not counted.

(22)Total fuel consumption [ml]

It shows the total fuel consumption from the factory delivery. There may be some discrepancy from the actual consumption because it is calculated from how long the fuel injected from the injector.

Atmospheric pressure	1014 hPa	<input type="button" value="Mon Stop"/>
Fuel pressure	0 kPa	
Power supply voltage	15.4 V	
3.3V voltage	3330 mV	
5V voltage	5011 mV	
12V voltage	12114 mV	
Head temperature	350 °C	
Throttle signal input	0 %	
Throttle signal output	20 %	
Trim signal Width	1520 us	
Rotation speed	0 rpm	
Fuel consumption	0 ml	
Operating time	00 : 00 : 00	
Current1 (Battery charging)	0.4 A	
Current2 (Power generation)	9.8 A	
*		

Sensor	
<input checked="" type="checkbox"/>	Current1
<input checked="" type="checkbox"/>	Current2
<input type="checkbox"/>	Current3
<input type="checkbox"/>	Current4
<input type="checkbox"/>	Voltage1
<input type="checkbox"/>	Voltage2
<input type="checkbox"/>	Fuel level1
<input type="checkbox"/>	Fuel level2

Generated electricity [W]	Power consumption [W]
152	152
Total operation time [h:m:s]	Total fuel consumption [ml]
02 : 00 : 52	1273

(Display example)

Starting the engine

- 【1】 Fill the fuel tank with fuel before turning on the switches of the ECU and the Igniter.
- 【2】 If there are air bubbles in the tube between the fuel tank and the fuel pump unit after filling up the fuel tank, open the pressure release valve and eliminate the air bubbles.

NOTE :

Locate the pressure release valve in a place easily accessible to open and close it before/after a day's use.

- 【3】 Turn on the ECU.
- 【4】 Power LED is lit and Operation status LED blinks.
- 【5】 The Fuel pump starts working as soon as the ECU is turned on. If the Pressure release valve is open, close it only after airbubbles in the system are gone. When fuel pressure reaches specified value, the Pump works intermittently or stops.



NOTE:

In case the the fuel pressure to the injector doesn't reach the specified value after turning on the switch within 30 seconds, the ECU beeps intermittently and the pump stops. (Turn off the switch and turn it on again when you reset the ECU)

- 【6】 Move the throttle stick to check the movement of the throttle servo. If the ECU is in starting mode and the Operation status LED is blinking, you can't close the throttle completely but it still remains open a little even if you move the throttle stick fully down. During the start mode, if throttle is open and close in short period, choke function and warning alarm will activate. For detail, please read choke section of the manual.
- 【7】 Position the throttle stick fully down when you start the engine. Preparation is complete.

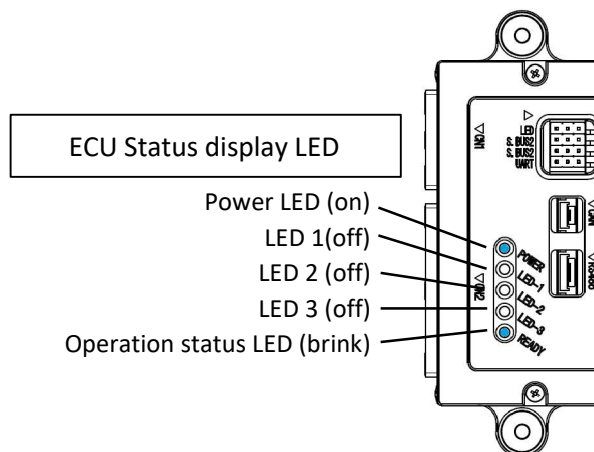

9.How to operate the engine

【8】When the power to the igniter is turned on and the cell starter signal is turned on, SGM cranks and starts the engine.

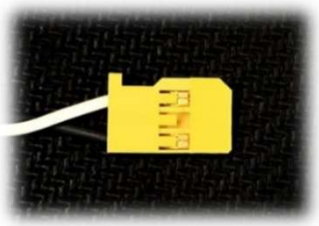
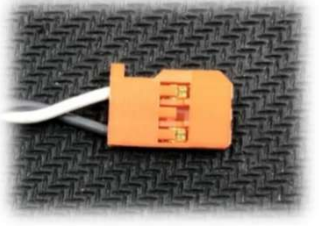
A-1	 <p style="text-align: center;">IgnitionON/OFF signal input</p>	<ul style="list-style-type: none"> ▪ Input the command signal to power on/off for igniter from the external device. ▪ If the PWM signal is between 800μs~1400μs, the igniter power switch is off (standby mode). ▪ When the PWM signal is between 1600μs~2200μs, the igniter will be powered on. When the ECU is started, if the PWM signal is not between 800μs~1400μs, It will not turn on unless it is put into standby mode for 800μs to 1400μs.
A-1	 <p style="text-align: center;">Starter signal input</p>	<ul style="list-style-type: none"> ▪ Input the PWM signal from the external device such as transmitter, flight controller etc. to start the starter motor. ▪ The starter goes into standby mode when the PWM signal is 800 μs to 1400 μs. ▪ The PWM signal drives the starter at 1600 μs to 2200 μs. ▪ When ECU is started, if PWM signal is 1600μs or more, it will sound the alarm and stop functioning to prevent malfunction.

NOTE:

- To ensure cranking by SGM, the ECU rotates the crank in the reverse direction(about 180 degrees) to build up compressed pressure of piston and then turns to the forward rotation to start engine.
- SGM cannot crank the engine without the propeller attached because of no inertia.
- If the battery voltage drops below 45V, it may not be possible to crank the engine. In that case, start using an external starter or the like.

【9】 Engine rpm goes up right after starting the engine, but it goes down immediately.

【10】 Idling rpm control system starts working when cylinder head temperature reaches the set temperature otherwise the idling rpm is kept at the set rpm.

9.How to operate the engine

• the followings are display LED message's meaning.

	Power LED	LED 1	LED 2	LED 3	READY LED	
engine start mode	On	Off	Off	Off	Blink	
engine operation	On	Blink	Blink	Blink	On	(note.1)
fuel pressure abnormal (pressure low)	On	Blink	Off	Off	Off	at the same time, a buzzer sounds
engine stop	On	Off	Off	On	Off	at the same time, a buzzer sounds
The set parameters are damaged	On	Off	Off	Blink	Off	at the same time, a buzzer sounds
System error 1	On	Blink	Blink	Blink	Blink	at the same time, a buzzer sounds
System error 2	On	Off	Blink	Blink	Off	at the same time, a buzzer sounds

Note.1 since the LED1, LED2 and LED3 are the monitor lamp of each signal, so they flashes at high speed during engine operation.

LED1	Crankshaft rotation sensor signal input
LED2	Injector drive signal output
LED3	Igniter started signal output

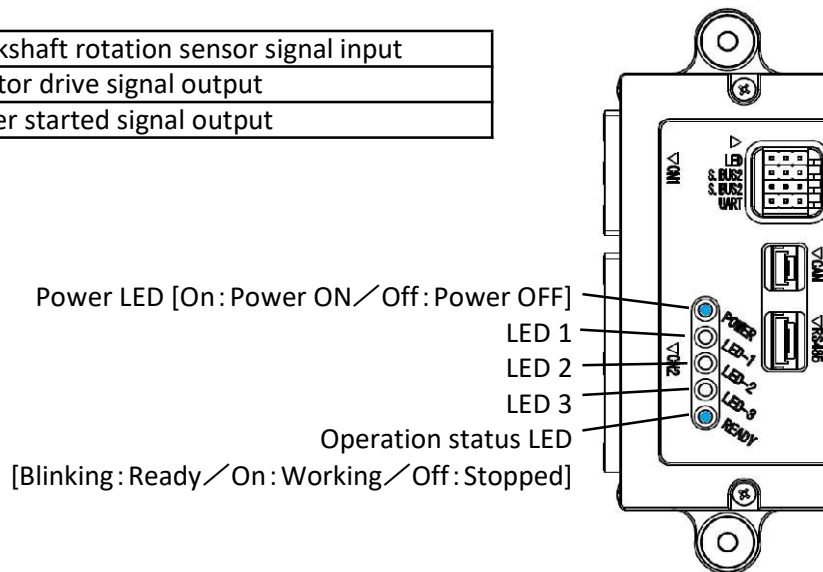

Choke

It is not necessary when starting with a cell starter, but the EC-13 has a choke function in case a choke is required for starting with a safety stick. The choke function works only in the engine start mode. The choking method is as follows.

【1】 In the engine start mode, when the throttle signal is opened from the state where the opening is 20% or less to the opening of 80% or more within 1 second, and then closed to the opening of 20% or less within 1 second, the injector injects the fuel for the choke once. At that time, the ECU sounds the warning alarm once.

【2】 If the same operation is performed again, fuel will be injected in the same way, but in order to prevent over-choke, use the choke function only once or twice , and flip the propeller with a safety stick each time to start the engine while checking for flow of fuel in the fuel line.

CAUTION :

Never start by flipping the propeller directly by hand as it may cause unexpected injuries. Be sure to use a cell starter, an external starter, or a safety stick.

Stopping the engine ①

【1】Input the ignition ON/OFF signal to turn off the igniter to stop the engine.

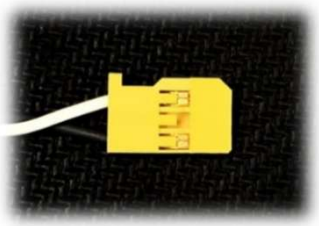
A-1		<ul style="list-style-type: none"> • Input the command signal to power on/off for igniter from the external device. • If the PWM signal is between 800μs~1400μs, the igniter power switch is off (standby mode). • When the PWM signal is between 1600μs~2200μs, the igniter will be powered on. When the ECU is started, if the PWM signal is not in the range between 800μs~1400μs, It will not turn on unless it is put into standby mode for 800μs to 1400 μs.
IgnitionON/OFF signal input		<p>Specification PWM signal : 800μs~2200μs [W : Signal / B : GND] VIH=2.6V, VIL=0.4V, MAX5.5V</p>

【2】The ECU stops the fuel pump and emits Beep sound intermittently when it detects engine stop.

【3】To turn off the ECU, you will need to disconnect the battery.

【4】Release the residual pressure in the fuel system after a days use to avoid fuel expanding the fuel joints and causing leaks.

Stopping the engine ②

By using application software(Engine setting_ xxx.exe)(XXXX is name of the version), the engine stop function can be set. Enter throttle signal and you can use the throttle signal input to instruct the ECU to stop the engine.

《Setting the engine stop function》

【1】Connection of ECU and PC

• Turn on the switch of the ECU.For connection, use the serial signal converter in the same way as when using EC13-LINK.

【1】Turning on the ECU

• Turn on the switch of the ECU.

【3】Starting up the software.

• Execute the file {Engine setting_ xxx.exe} and open the following window.

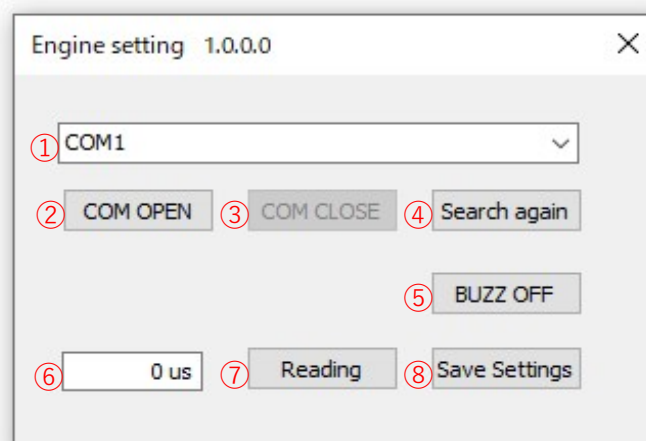

10. How to operate the engine

【4】Confirming COM port assignment.

- Make sure which COM port is assigned to the ECU serial connection by Windows® device manager.
- In case the assigned COM port is other than COM1 ~ COM10, reassign it to one of the port from COM1 to COM10. Refer to the instruction manual of the Windows® you are using how to assign a COM port.

【5】Setting the COM port.

- Select the confirmed COM port from the pull-down menu (① in the above picture). Click the [COM OPEN] button (② in the above picture) and the connection is completed.
- In the pull-down menu of ①, you can see what kind of connection (“USB serial port” in this sample below) next to port number (COM3 in this case). You can make a choice from the pull-down menu. In case you cannot find a connection, click ④ [Search again]. If it's still not displayed, check using the Windows® device manager etc and set up the port number.

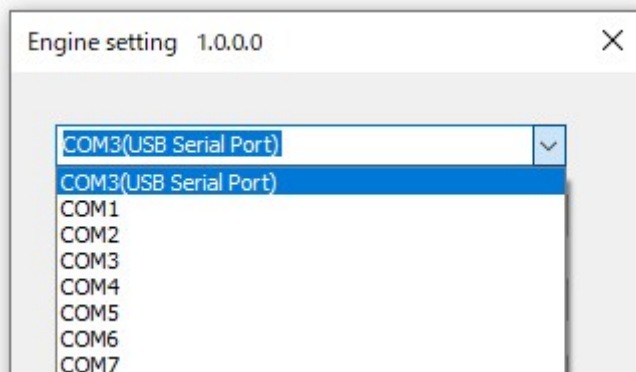

【6】Setting the threshold of pulse width of throttle signal (PWM) in ⑥, which carries out Engine Stop.

- The setting, 0 μ s invalids the Engine Stop operation.
- The setting range is 1 ~ 9999 μ s.
- Within the setting range 1 ~ 9999 μ s, when the throttle signal input pulse width keeps lower than the setting value for more than 0.5 second, the Engine Stop operation is carried out.

【7】Click the [Save Settings](⑧ in the above picture).

- The new setting is not memorized unless you click [SAVE Setting].

【8】Turn off the ECU and turn it on again to make the setting valid.

After making this setting, the ECU will stop the engine if the PWM signal width of the throttle signal input is held below the set threshold value for 0.5 second or longer.

Restarting the ECU

When the engine stops, the ECU stops the fuel pump, sounds the intermittent warning buzzer, and the engine will go into shut off mode. The engine cannot be restarted in this state.

To restart the engine, it is necessary to restart the ECU. There are three ways to restart the ECU.

- (1) Turn off the power of the ECU and then turn it on again.
 - (2) Use the serial communication function to send a restart command to the ECU. (See Communication Protocol section)
 - (3) Use the starter signal input to give an instruction to restart the ECU.
- On this page, we will explain the method (3).

• Starter signal input connector

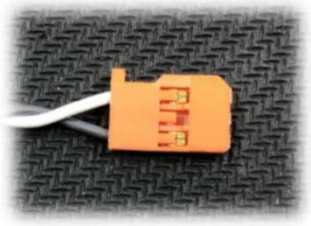
A-1	 <p>Starter signal input</p>	<ul style="list-style-type: none"> • Input the PWM signal from the external device such as transmitter, flight controller etc. to start the starter motor. • The starter goes into standby mode when the PWM signal is 800 μs to 1400 μs. • The PWM signal drives the starter at 1600 μs to 2200 μs.
<p>Specification PWM signal : 800μs~2200μs [W:Signal / B:GND] VIH=2.6V, VIL=0.4V, MAX5.5V</p>		

If you input 1600μs to 2200μs of PWM signal from the Starter signal input connector for 2 seconds or more continuously during the engine stop mode, the ECU will restart.

After the ECU restarted, if the PWM signal of the Starter signal input connector becomes 800 μs to 1400 μs, the starter will be in the standby state.

Right after the ECU restarted(more than 3 seconds), if the ECU detects the PWM signal of 1600μs~2200 μs from the Starter signal input connector continuously, to prevent malfunction, the ECU will enter into the engine shutdown mode and cease functioning. In this state, it will not accept restart command. To recover, the ECU will need to be turned off and then on again, or to input reset command with serial communication. Bring back the Starter signal input connector's PWM signal to 800μs~1400μs within 3 seconds after the ECU restarted.

11. Communication protocol(COM)

《Command》

Command【MON】 Reads 25 items of ECU internal information.

• command format

item	size	data (ASCII)	range
start mark	1byte	STX	0x02
command	3byte	"MON"	0x4D,0x4F,0x4E
end mark	1byte	ETX	0x03
BCC(XOR from command to end mark)	1byte	"O"	0x4F

• response format

item	size	data (ASCII)	range
start mark	1 byte	02h	02h(2)
status	1 byte	"0"	30h(48)
	1byte	" "	0x20
① barometric pressure	unit: hPa 4byte	"8000" ~ "7FFF"	0x8000 ~ 0x7FFF (-32768 ~ 32767)
	1byte	" "	0x20
② fuel pressure	unit: kPa 4byte	"8000" ~ "7FFF"	0x8000 ~ 0x7FFF (-32768 ~ 32767)
	1byte	" "	0x20
③ power supply (Battery voltage)	unit: dV 4byte	"8000" ~ "7FFF"	0x8000 ~ 0x7FFF (-32768 ~ 32767)
	1byte	" "	0x20
④ power supply (ECU internal 3.3V)	unit: mV 4byte	"8000" ~ "7FFF"	0x8000 ~ 0x7FFF (-32768 ~ 32767)
	1byte	" "	0x20
⑤ power supply (ECU internal 5V)	unit: mV 4byte	"8000" ~ "7FFF"	0x8000 ~ 0x7FFF (-32768 ~ 32767)
	1byte	" "	0x20
⑥ power supply (ECU internal 12V)	unit: mV 4byte	"8000" ~ "7FFF"	0x8000 ~ 0x7FFF (-32768 ~ 32767)
	1byte	" "	0x20
⑦ cylinder head temperature	unit: °C 4byte	"8000" ~ "7FFF"	0x8000 ~ 0x7FFF (-32768 ~ 32767)
	1byte	" "	0x20
⑧ throttle signal input from receiver (Min.output to max., 0% to 100%)	unit: % 4byte	"8000" ~ "7FFF"	0x8000 ~ 0x7FFF (-32768 ~ 32767)
	1byte	" "	0x20
⑨ signal output to throttle servo (fully close ~ fully open 0% ~ 100%)	unit: % 4byte	"8000" ~ "7FFF"	0x8000 ~ 0x7FFF (-32768 ~ 32767)
	1byte	" "	0x20
⑩ fuel trim signal input from receiver (Pulse width of the PWM signal)	unit: μs 4byte	"8000" ~ "7FFF"	0x8000 ~ 0x7FFF (-32768 ~ 32767)
	1byte	" "	0x20
⑪ engine rotation speed	unit: rpm 4byte	"8000" ~ "7FFF"	0x8000 ~ 0x7FFF (-32768 ~ 32767)
	1byte	" "	0x20
⑫ Fuel consumption (After ECU startup)	unit: ml 8byte	"00000000" ~ "FFFFFFF"	0x00000000 ~ 0xFFFFFFFF (0 ~ 4294967295)

Continued on next page

11. Communication protocol(COM)

Continued from the previous page

			1byte	" "	0x20
DATA	⑬ Operation time (After ECU startup)	unit: sec	8byte	"00000000"~ "FFFFFFF"	0x00000000~0xFFFFFFFF (0~4294967295)
			1byte	" "	0x20
	⑭ Current(Current1) (Battery Charging Current)	unit: dA	4byte	"8000"~"7FFF"	0x8000~0x7FFF (-32768~32767)
			1byte	" "	0x20
	⑮ Current(Current2) (Generated current)	unit: dA	4byte	"8000"~"7FFF"	0x8000~0x7FFF (-32768~32767)
			1byte	" "	0x20
	⑯ Current(Current3) (Option) *1	unit: dA	4byte	"8000"~"7FFF"	0x8000~0x7FFF (-32768~32767)
			1byte	" "	0x20
	⑰ Current(Current4) (Option) *1	unit: dA	4byte	"8000"~"7FFF"	0x8000~0x7FFF (-32768~32767)
			1byte	" "	0x20
	⑱ Voltage(Voltage1) (Option) *1	unit: dV	4byte	"8000"~"7FFF"	0x8000~0x7FFF (-32768~32767)
			1byte	" "	0x20
	⑲ Voltage(Voltage2) (Option) *1	unit: dV	4byte	"8000"~"7FFF"	0x8000~0x7FFF (-32768~32767)
			1byte	" "	0x20
	⑳ Fuel Level Sensor(Fuel Level1) (Option) *1	unit: %	4byte	"8000"~"7FFF"	0x8000~0x7FFF (-32768~32767)
			1byte	" "	0x20
	㉑ Fuel Level Sensor(Fuel Level2) (Option) *1	unit: %	4byte	"8000"~"7FFF"	0x8000~0x7FFF (-32768~32767)
			1byte	" "	0x20
	㉒ Generated electricty	unit: W	4byte	"8000"~"7FFF"	0x8000~0x7FFF (-32768~32767)
			1byte	" "	0x20
	㉓ Power consumption	unit: W	4byte	"8000"~"7FFF"	0x8000~0x7FFF (-32768~32767)
			1byte	" "	0x20
	㉔ Total operation time	unit: sec	8byte	"00000000"~ "FFFFFFF"	0x00000000~0xFFFFFFFF (0~4294967295)
			1byte	" "	0x20
	㉕ Total fuel consumption	unit: ml	8byte	"00000000"~ "FFFFFFF"	0x00000000~0xFFFFFFFF (0~4294967295)
		1byte	NUL	0x00	
end mark		1byte	ETX	0x03	
BCC(XOR from status to end mark)		1byte			

*1: (Optional) items have values that can be read even if the optional sensor is not installed, but the values are meaningless.

11. Communication protocol(COM)

Command【TFC】 Reads the total fuel consumption.

• command format

item	size	data (ASCII)	range
start mark	1byte	STX	0x02
command	3byte	"TFC"	0x54,0x46,0x43
end mark	1byte	ETX	0x03
BCC(XOR from command to end mark)	1byte	"R"	0x52

• response format

item	size	data (ASCII)	range
start mark	1byte	STX	0x02
status	1byte	"0"	0x30
	1byte	" "	0x20
DATA ① Total fuel consumption	unit: ml 8byte	"00000000"~ "FFFFFFF"	0x00000000~0xFFFFFFFF (0~4294967295)
Null-terminated string	1byte	NUL	0x00
end mark	1byte	ETX	0x03
BCC(XOR from status to end mark)	1byte		

Command【TOT】 Reads the total operation time.

• command format

item	size	data (ASCII)	range
start mark	1byte	STX	0x02
command	3byte	"TOT"	0x54,0x4F,0x54
end mark	1byte	ETX	0x03
BCC(XOR from command to end mark)	1byte	"L"	0x4C

• response format

item	size	data (ASCII)	range
start mark	1byte	STX	0x02
status	1byte	"0"	0x30
	1byte	" "	0x20
DATA ① Total operation time	unit: sec 8byte	"00000000"~ "FFFFFFF"	0x00000000~0xFFFFFFFF (0~4294967295)
Null-terminated string	1byte	NUL	0x00
end mark	1byte	ETX	0x03
BCC(XOR from status to end mark)	1byte		

11.Communication protocol(COM)

Command【RST】 Restart the ECU.

• command format

item	size	data (ASCII)	range
start mark	1byte	STX	0x02
command	3byte	"RST"	0x52,0x53,0x54
end mark	1byte	ETX	0x03
BCC(XOR from status to end mark)	1byte	"V"	0x56

• response format

item	size	data (ASCII)	range
start mark	1byte	STX	0x02
status	1byte	"0"	0x30
end mark	1byte	ETX	0x03
BCC(XOR from status to end mark)	1byte	"3"	0x33

11. Communication protocol(CAN)

•The internal data of the ECU can be collected by other external devices through its CAN communication function. The communication protocol would show as followings.

《communication specification》

- CAN
- Pin assignment (ECU side connector)

1	+5V power supply output
2	Signal(High)
3	Signal(Low)
4	GND

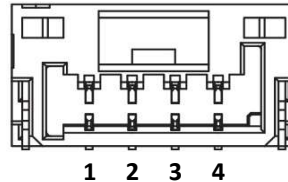

• Connector : JST-GH (4pin)

4 pin JST-GH

《data format》

- Data frame

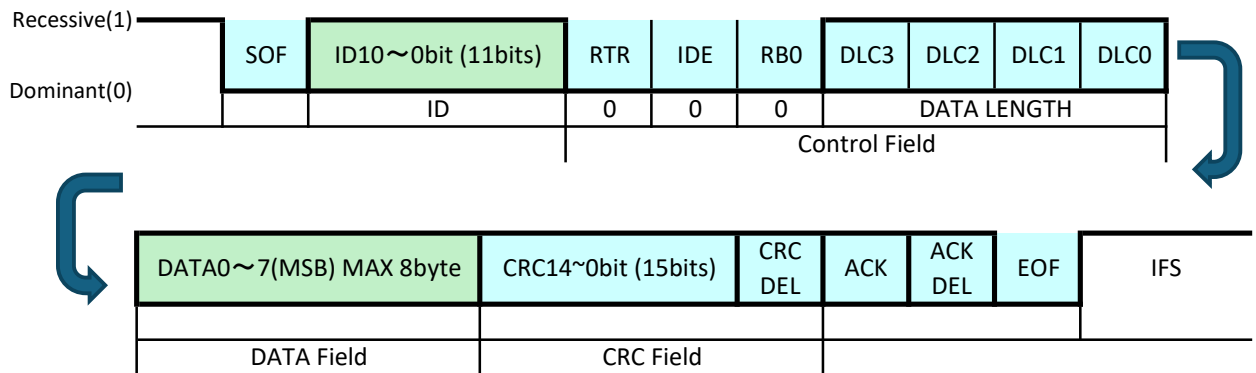

11. Communication protocol(CAN)

• RX Data (input of command values to the ECU)

NAME	ID (*)		DATA LENGTH	DATA 0~7		DATA RANGE
				0~5	6~7	
data_ch1	256	0x100	8	0x000000000000	DATA	0x0000 (0) ~ 0xFFFF (65535)
data_ch2	257	0x101	8	0x000000000000	DATA	
data_ch3	258	0x102	8	0x000000000000	DATA	
data_ch4	259	0x103	8	0x000000000000	DATA	
data_ch5	260	0x104	8	0x000000000000	DATA	
data_ch6	261	0x105	8	0x000000000000	DATA	
data_ch7	262	0x106	8	0x000000000000	DATA	
data_ch8	263	0x107	8	0x000000000000	DATA	
data_ch9	264	0x108	8	0x000000000000	DATA	
data_ch10	265	0x109	8	0x000000000000	DATA	
data_ch11	266	0x10A	8	0x000000000000	DATA	
data_ch12	267	0x10B	8	0x000000000000	DATA	
data_ch13	268	0x10C	8	0x000000000000	DATA	
data_ch14	269	0x10D	8	0x000000000000	DATA	
data_ch15	270	0x10E	8	0x000000000000	DATA	
data_ch16	271	0x10F	8	0x000000000000	DATA	
data_ch17	272	0x110	8	0x000000000000	DATA	
data_ch18	273	0x111	8	0x000000000000	DATA	
data_ch19	274	0x112	8	0x000000000000	DATA	
data_ch20	275	0x113	8	0x000000000000	DATA	
data_ch21	276	0x114	8	0x000000000000	DATA	
data_ch22	277	0x115	8	0x000000000000	DATA	
data_ch23	278	0x116	8	0x000000000000	DATA	
data_ch24	279	0x117	8	0x000000000000	DATA	

*The start address of the ID can be changed using the CAN setting software. Refer to page 66 onward.
It occupies 24 consecutive IDs. Set the ID range not overlapping with other devices on the CAN bus.

11. Communication protocol(CAN)

【RX Data Reception (Input of Command Values to the ECU)】

The time value (μsec) corresponding to the pulse width of the PWM signal from the RC receiver is converted using the conversion table below, then sent to and input into the ECU.

A total of 24 channels, Channel 1 through Channel 24 are available.

• Conversion table

PWM pulse width	Value
880 μsec (Lower limit)	0x0000
1520 μsec (Center)	0x0400
2160 μsec (Maximum)	0x07FF

■ Throttle signal input

1100 μsec (0x0160): minimum engine output ~ 1940 μsec (0x06A0): maximum engine output.

The ECU recognizes any value of 1100 μsec (0x0160) or lower as 1100 μsec , and any value of 1940 μsec (0x06A0) or higher as 1940 μsec .

■ Starter signal input

The value between 1000 μsec and 1400 μsec (0x0C0 to 0x0340), the starter is in standby mode.

The value between 1600 μsec and 2000 μsec (0x0480 to 0x0700), the starter is activated.

If the signal is 1600 μsec (0x0480) or higher when the ECU is powered on, the ECU issues an alarm and stops the function to prevent malfunction.

■ Fuel trim signal input

1520 μsec (neutral) $\pm 420 \mu\text{sec}$. (0x0160 to 0x0400 to 0x06A0)

The positive (+) side of the PWM signal width corresponds to an increase in fuel amount. The fuel adjustment range is $\pm 30\%$.

The ECU treats any value of 1100 μsec (0x0160) or lower as 1100 μsec , and any value of 1940 μsec (0x06A0) or higher as 1940 μsec .

■ IgnitionON/OFF signal input

The value between 1000 μsec and 1400 μsec (0x0C0 to 0x0340), the igniter power switch is OFF (standby mode).

The value between 1600 μsec and 2000 μsec (0x0480 to 0x0700), power is supplied to the igniter.

If the signal is outside the range between 1000 μsec and 1400 μsec (0x0C0 to 0x0340) at ECU startup, the igniter cannot be turned ON until a value within the range between 1000 μsec and 1400 μsec (0x0C0 to 0x0340) is sent once to set it to standby mode.

11. Communication protocol(CAN)

• DATA

NAME	ID		DATA LENGTH	DATA 0~7		DATA RANGE
				0~5	6~7	
Pressure (hPa)	768	0x300	8	0x000000000000	DATA	0x8000 (-32768) ~ 0x7FFF (32767)
Fuel pressure (kPa)	769	0x301	8	0x000000000000	DATA	
Power supply voltage(dV)	770	0x302	8	0x000000000000	DATA	
3.3V voltage (mV)	771	0x303	8	0x000000000000	DATA	
5V voltage (mV)	772	0x304	8	0x000000000000	DATA	
12V voltage (mV)	773	0x305	8	0x000000000000	DATA	
Head temperature(°C)	774	0x306	8	0x000000000000	DATA	
Throttle signal input (%)	775	0x307	8	0x000000000000	DATA	
Throttle signal output (%)	776	0x308	8	0x000000000000	DATA	
Trim signal Width (μs)	777	0x309	8	0x000000000000	DATA	
Rotation speed (rpm)	778	0x30A	8	0x000000000000	DATA	
Current1(Battery Charging Current)(dA)	779	0x30B	8	0x000000000000	DATA	
Current2(Power generation current)(dA)	780	0x30C	8	0x000000000000	DATA	
Current3(Optional)(dA)	781	0x30D	8	0x000000000000	DATA	
Current4(Optional)(dA)	782	0x30E	8	0x000000000000	DATA	
Voltage1(Optional)(dV)	783	0x30F	8	0x000000000000	DATA	
Voltage2(Optional)(dV)	784	0x310	8	0x000000000000	DATA	
Fuel Level1(Optional)(%)	785	0x311	8	0x000000000000	DATA	
Fuel Level2(Optional)(%)	786	0x312	8	0x000000000000	DATA	
Generated electricity(W)	787	0x313	8	0x000000000000	DATA	
Power consumption(W)	788	0x314	8	0x000000000000	DATA	
Altitude(m(x10))	789	0x315	8	0x000000000000	DATA	
NAME	ID		DATA LENGTH	DATA 0~7		DATA RANGE
				0~3	4~7	
Operating time (sec)	790	0x316	8	0x00000000	DATA	0x00000000 (0) ~ 0xFFFFFFFF (4294967295)
Fuel consumption (ml)	791	0x317	8	0x00000000	DATA	
Total operation time (sec)	792	0x318	8	0x00000000	DATA	
Total fuel consumption (ml)	793	0x319	8	0x00000000	DATA	

* The start address of the ID can be changed using the CAN setting software. Refer to page 66 onward.
It occupies 26 consecutive IDs. Set the address not overlapping with other devices on the CAN bus.

11. Communication protocol(CAN)

《CAN setting software》

Use the serial signal converter and the CAN setting software {EC23_CAN setting_ xxxx.exe} (xxxx is the version name) to set the CAN of the ECU.

【Separately required items】

• PC with Windows® (10/11) and USB port. The included U2S-2 (serial signal converter) uses an FTDI chip, the driver is registered in Windows® Update. Therefore, in internet environment, the driver is automatically downloaded and installed by connecting the USB serial converter to the PC. Install the driver in advance in an internet environment.

【Installing software into PC】

- There is no installation program for CAN setting software. Copy the software {EC23_CAN setting_ xxxx.exe} to any location on your computer (hereafter PC). After copying it to any location, execute {EC23_CAN setting_ xxxx.exe} directly.
- When deleting the software, delete the {EC23_CAN setting_ xxxx.exe} file from the PC.

《Setting》

【1】Connecting serial signal port

- Connect the 4-pin connector of U2S-2 to the ECU's serial communication connector (A-2).
- Connect the U2S-2 main unit to the USB port of the PC.

【2】Powering the ECU

- Turn on the power of ECU



CAUTION :

- Do not turn on the ECU if the fuel is not going into the fuel pump. If fuel pump runs without any fuel, it may cause damage to the pump.
- If you need to power on the ECU without fuel, such as when changing settings using CAN configuration software, disconnect the pump connector and do not operate the pump. In that case, the buzzer (alarm) sounds due to abnormal fuel pressure 30 seconds after the ECU is turned on, but you can stop the buzzer by clicking the "BUZZ OFF" button in the CAN setting software.

11. Communication protocol(CAN)

【3】Starting up the software

- Execute {EC23_CAN setting_xxx.exe} copied to the PC. The window will open(picture below).

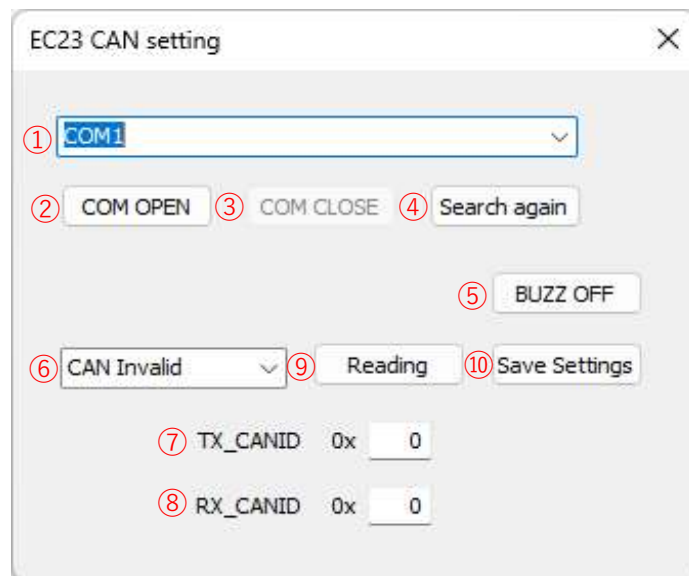

【4】Confirming the COM port allocation

- Check which COM port the serial connection with the ECU is assigned to, using Windows® Device Manager, etc.
- At this time, if it is allocated outside the range of COM1 to COM10, change it to one of COM1 to COM10. For how to change, refer to the operation method of each Windows® you are using.

【5】Setting COM port

- Select the confirmed COM port from the pull-down menu (① in the above picture). Click the [COM OPEN] button (② in the above picture) and the connection is completed.
- In the pull-down menu of ①, you can see what kind of connection (“USB serial port” in this sample below) next to port number (COM3 in this case). You can make a choice from the pull-down menu. In case you cannot find a connection, click ④ [Search again]. If you still can't see it, check Windows® Device Manager and set the port number.

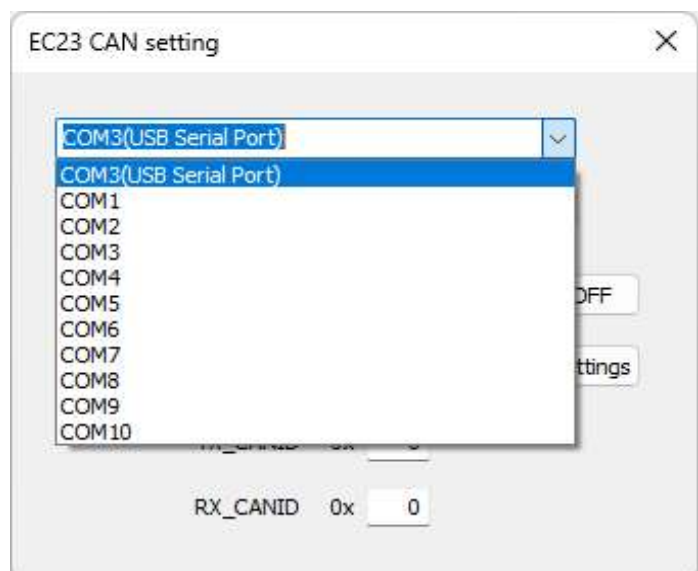

11. Communication protocol(CAN)

【6】Select CAN Invalid or communication speed from the pull-down menu in ⑥.

- Communication speed can be selected from 125Kbps, 250Kbps, 500Kbps, 1Mbps and CAN Invalid.
- If the communication speed is specified, CAN will be valid and the ECU will send data for ID: 0x300 to 0x319(default) only once at intervals of about 100ms. With this CAN system, the data cannot be resent in case of an error.
- Refer to page 64 for the data format.

【7】Set the initial CAN ID for data transmission (data reception from the ECU) in ⑦.

- A value from 0x0 to 0x7FF can be specified.
- Including the setting value, 26 IDs will be occupied.
- If 0x7FF is set, the following 26 IDs will be occupied: 0x7FF, 0x0, 0x1, ..., 0x18.
- Set the CAN ID so that it does not overlap with the IDs of other devices connected to the CAN bus, including the ID used for receiving command values.

【8】Set the initial CAN ID for command value reception (command value transmission to the ECU) in ⑧.

- A value from 0x0 to 0x7FF can be set.
- Including the setting value, 24 IDs will be occupied.
- If 0x7FF is set, the following 24 IDs will be occupied: 0x7FF, 0x0, 0x1, ..., 0x16.
- Set the CAN ID so that it does not overlap with the IDs of other devices connected to the CAN bus, including the ID used for data transmission.

【9】Click the [Save Settings](⑨ in the above picture).

- The new setting is not memorized unless you click [SAVE Setting].

【10】Turn off the ECU and turn it on again to make the setting valid.

- Pressing the [BUZZ OFF] button ⑤ will stop the buzzer from sounding.
- Pressing the [Reading] button ⑨ will read the settings currently stored in the ECU.

11.Communication protocol(RS485)

- The internal data of the ECU can be collected by other external devices through its RS485 serial communication function.
- By using RS485 serial communication function on the ECU, it can send indicated value to the ECU.

《communication specification》

• RS485

• Pin assignment (ECU side connector)

1	RXD(+)
2	RXD(-)
3	TXD(-)
4	TXD(+)
5	+5V power supply output
6	GND

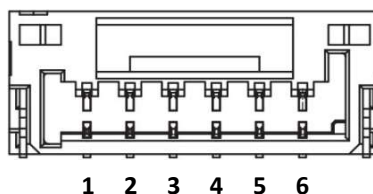

6 pin JST-GH

• Connector : JST-GH (6pin)

• Protocol

Bit rate	115,200bps
Start bit	1bit
Data length	8bit
Stop bit	1bit
Parity	Even parity
Byte order	LSB first
Frequency	Sending 10Hz/Receiving 70Hz

【Real-time data reception (Input indicated value to the ECU)】

PWM signal used in the RC receiver's pulse width is converted to a value using the conversion table below, then sent and input to the ECU. Channels range from 1 to 24. Selecting RS485 and allocating each signal are performed by EC23-LINK. For how to set up, refer to EC23-LINK section.

• Conversion table

PWM Pulse width	Value
880μsec(minimum)	0x0000
1520μsec(Center)	0x0400
2160μsec(maximum)	0x07FF

■ Throttle signal input

1100μsec(0x0160)Engine minimum power output~1940μsec(0x06A0)Engine maximum power output.

■ Starter signal input

At 1000μsec~1400μsec(0x0C0~0x0340), the starter will be in standby mode.

At 1600μsec~2000μsec(0x0480~0x0700), it drives the starter.

If it exceeds 1600μsec(0x0480)when the ECU starts up, the ECU will sound the alarm and stop functioning to prevent malfunction.

■ Fuel trim signal input

1520μsec(Neutral)±420μsec。 (0x0160~0x0400~0x06A0)

On PWM pulse width, the + (plus) side increases fuel volume and fuel increase/decrease volume range is ±30%.

■ IgnitionON/OFF signal input

At 1000μsec~1400μsec(0x0C0~0x0340), the igniter power switch will be OFF(stand by mode).

At 1600μsec~2000μsec(0x0480~0x0700) it power the igniter.

At the ECU start up, if its under 1000μsec~1400μsec(0x0C0~0x0340), it will not turn on unless you send (0x0C0~0x0340) and put it into standby mode.

11.Communication protocol(RS485)

▪ Packet

Name	Real-time data reception (sending indication values to ECU)
Category	Operation
Size	53Byte
Packet transmission time	5.061ms
Frequency	70Hz

No.	Item	Size (Byte)	Content	Remark
1	Header	1	0xAA (fixed)	A fixed value that indicates the beginning of the data.
2	length	1	0x22(fixed)	Total data size from No.3 to No.20.(fixed)
3	data_ch1	2	0x0000(880usec)~0x07FF(2160usec)	unused (0x0400 fixed)
4	data_ch2	2	0x0000(880usec)~0x07FF(2160usec)	unused (0x0400 fixed)
5	data_ch3	2	0x0000(880usec)~0x07FF(2160usec)	unused (0x0400 fixed)
6	data_ch4	2	0x0000(880usec)~0x07FF(2160usec)	unused (0x0400 fixed)
7	data_ch5	2	0x0000(880usec)~0x07FF(2160usec)	unused (0x0400 fixed)
8	data_ch6	2	0x0000(880usec)~0x07FF(2160usec)	unused (0x0400 fixed)
9	data_ch7	2	0x0000(880usec)~0x07FF(2160usec)	unused (0x0400 fixed)
10	data_ch8	2	0x0000(880usec)~0x07FF(2160usec)	unused (0x0400 fixed)
11	data_ch9	2	0x0000(880usec)~0x07FF(2160usec)	unused (0x0400 fixed)
12	data_ch10	2	0x0000(880usec)~0x07FF(2160usec)	unused (0x0400 fixed)
13	data_ch11	2	0x0000(880usec)~0x07FF(2160usec)	unused (0x0400 fixed)
14	data_ch12	2	0x0000(880usec)~0x07FF(2160usec)	unused (0x0400 fixed)
15	data_ch13	2	0x0000(880usec)~0x07FF(2160usec)	unused (0x0400 fixed)
16	data_ch14	2	0x0000(880usec)~0x07FF(2160usec)	unused (0x0400 fixed)
17	data_ch15	2	0x0000(880usec)~0x07FF(2160usec)	unused (0x0400 fixed)
18	data_ch16	2	0x0000(880usec)~0x07FF(2160usec)	unused (0x0400 fixed)
19	data_ch17	2	0x0000(880usec)~0x07FF(2160usec)	unused (0x0400 fixed)
20	data_ch18	2	0x0000(880usec)~0x07FF(2160usec)	unused (0x0400 fixed)
21	data_ch19	2	0x0000(880usec)~0x07FF(2160usec)	unused (0x0400 fixed)
22	data_ch20	2	0x0000(880usec)~0x07FF(2160usec)	unused (0x0400 fixed)
23	data_ch21	2	0x0000(880usec)~0x07FF(2160usec)	unused (0x0400 fixed)
24	data_ch22	2	0x0000(880usec)~0x07FF(2160usec)	unused (0x0400 fixed)
25	data_ch23	2	0x0000(880usec)~0x07FF(2160usec)	unused (0x0400 fixed)
26	data_ch24	2	0x0000(880usec)~0x07FF(2160usec)	unused (0x0400 fixed)
27	Footer	1	0xFF (fixed)	A fixed value that indicates the end of the data.
28	CRC	2		CRC-16-CCITT(Header to Footer)

11.Communication protocol(RS485)

【Real-time data reception (Input indicated value to the ECU)】

PWM signal used in the RC receiver's pulse width is converted to a value using the conversion table below, then sent and input to the ECU. Channels range from 1 to 24. Selecting RS485 and allocating each signal are performed by EC23-LINK. For how to set up, refer to EC23-LINK section.

• Conversion table

PWM Pulse width	Value
880μsec(minimum)	0x0000
1520μsec(Center)	0X0400
2160μsec(maximum)	0x07FF

■ Throttle signal input

1100μsec(0x0160)Engine minimum power output~1940μsec(0x06A0)Engine maximum power output.

■ Starter signal input

At 1000μsec~1400μsec(0x0C0~0x0340), the starter will be in standby mode.

At 1600μsec~2000μsec(0x0480~0x0700), it drives the starter.

If it exceeds 1600μsec(0x0480)when the ECU starts up, the ECU will sound the alarm and stop functioning to prevent malfunction.

■ Fuel trim signal input

1520μsec(Neutral)±420μsec。 (0x0160~0x0400~0x06A0)

On PWM pulse width, the + (plus) side increases fuel volume and fuel increase/decrease volume range is ±30%.

■ IgnitionON/OFF signal input

At 1000μsec~1400μsec(0x0C0~0x0340), the igniter power switch will be OFF(stand by mode).

At 1600μsec~2000μsec(0x0480~0x0700) it power the igniter.

At the ECU start up, if its under 1000μsec~1400μsec(0x0C0~0x0340), it will not turn on unless you send (0x0C0~0x0340) and put it into standby mode.

11.Communication protocol(RS485)

• Packet

Name	Real-time data transmission (receiving data from ECU)
Category	Sensors
Size	65Byte
Packet transmission time	6.207ms
Frequency	10Hz

No.	Item	Size (Byte)	Content	Remark
1	Header	1	0xAA (fixed)	A fixed value that indicates the beginning of the data.
2	length	1	0x3C(fixed)	Total data size from No.3 to No.28.(fixed)
3	Atmospheric pressure	2	0x8000 (-3,276.8 hPa) ~0x7FFF (3,276.7 hPa)	Barometric pressure
4	Fuel pressure	2	0x8000(-32,768 kPa) ~0x7FFF(+32,767 kPa)	Fuel pressure
5	Power supply voltage	2	0x8000 (-3,276.8 V) ~0x7FFF (3,276.7 V)	Rower supply voltage (Battery voltage)
6	3.3V voltage	2	0x8000(-32,768 mV) ~0x7FFF(+32,767 mV)	Power supply voltage (ECU internal 3.3V)
7	5V voltage	2	0x8000(-32,768 mV) ~0x7FFF(+32,767 mV)	Power supply voltage (ECU internal 5V)
8	12V voltage	2	0x8000(-32,768 mV) ~0x7FFF(+32,767 mV)	Power supply voltage (ECU internal 12V)
9	Head temperature	2	0x8000(-32,768 °C) ~0x7FFF(+32,767 °C)	Cylinder head temperature
10	Throttle signal input	2	0x8000(-32,768 %) ~0x7FFF(+32,767 %)	Throttle signal input from receiver.(Min.output to max., 0% to 100%)
11	Throttle signal output	2	0x8000(-32,768 %) ~0x7FFF(+32,767 %)	Signal output to throttle servo.(fully close~fully open 0%~100%)
12	Trim signal Width	2	0x8000(-32,768 us) ~0x7FFF(+32,767 us)	Fuel trim signal input from receiver.(Pulse width of the PWM signal)
13	Rotation speed	2	0x8000(-32,768 rpm) ~0x7FFF(+32,767 rpm)	Engine rotation speed
14	Current1(Battery charging)	2	0x8000 (-3,276.8 A) ~0x7FFF (3,276.7 A)	Current(Current1) (Battery Charging Current)
15	Current2(Power generation)	2	0x8000 (-3,276.8 A) ~0x7FFF (3,276.7 A)	Current(Current2) (Generated current)
16	Current3	2	0x8000 (-3,276.8 A) ~0x7FFF (3,276.7 A)	Current(Current3) (Option) *1
17	Current4	2	0x8000 (-3,276.8 A) ~0x7FFF (3,276.7 A)	Current(Current4) (Option) *1
18	Voltage1	2	0x8000 (-3,276.8 V) ~0x7FFF (3,276.7 V)	Voltage(Voltage1) (Option) *1
19	Voltage2	2	0x8000 (-3,276.8 V) ~0x7FFF (3,276.7 V)	Voltage(Voltage2) (Option) *1
20	Fuel level1	2	0x8000(-32,768 %) ~0x7FFF(+32,767 %)	Fuel Level Sensor(Fuel Level1) (Option) *1
21	Fuel level2	2	0x8000(-32,768 %) ~0x7FFF(+32,767 %)	Fuel Level Sensor(Fuel Level2) (Option) *1
22	Generated electricity	2	0x8000(-32,768 W) ~0x7FFF(+32,767 W)	Generated electrictty
23	Power consumption	2	0x8000(-32,768 W) ~0x7FFF(+32,767 W)	Power consumption
24	Altitude	2	0x8000(-3,276.8 m) ~0x7FFF(+3,276.7 m)	Altitude(from the point where the ECU is powered on)
25	Operating time	4	0x00000000(0sec) ~0xFFFFFFFF(4294967295sec)	Operation time (After ECU startup)
26	Fuel consumption	4	0x00000000(0ml) ~0xFFFFFFFF(4294967295ml)	Fuel consumption (After ECU startup)
27	Total operation time	4	0x00000000(0sec) ~0xFFFFFFFF(4294967295sec)	Total operation time
28	Total fuel consumption	4	0x00000000(0ml) ~0xFFFFFFFF(4294967295ml)	Total fuel consumption
29	Footer	1	0xFF (fixed)	A fixed value that indicates the end of the data.
30	CRC	2		CRC-16-CCITT(Header to Footer)

*1: (Optional) items have values that can be read even if the optional sensor is not installed, but the values are meaningless.

12. Assignment of the pins.

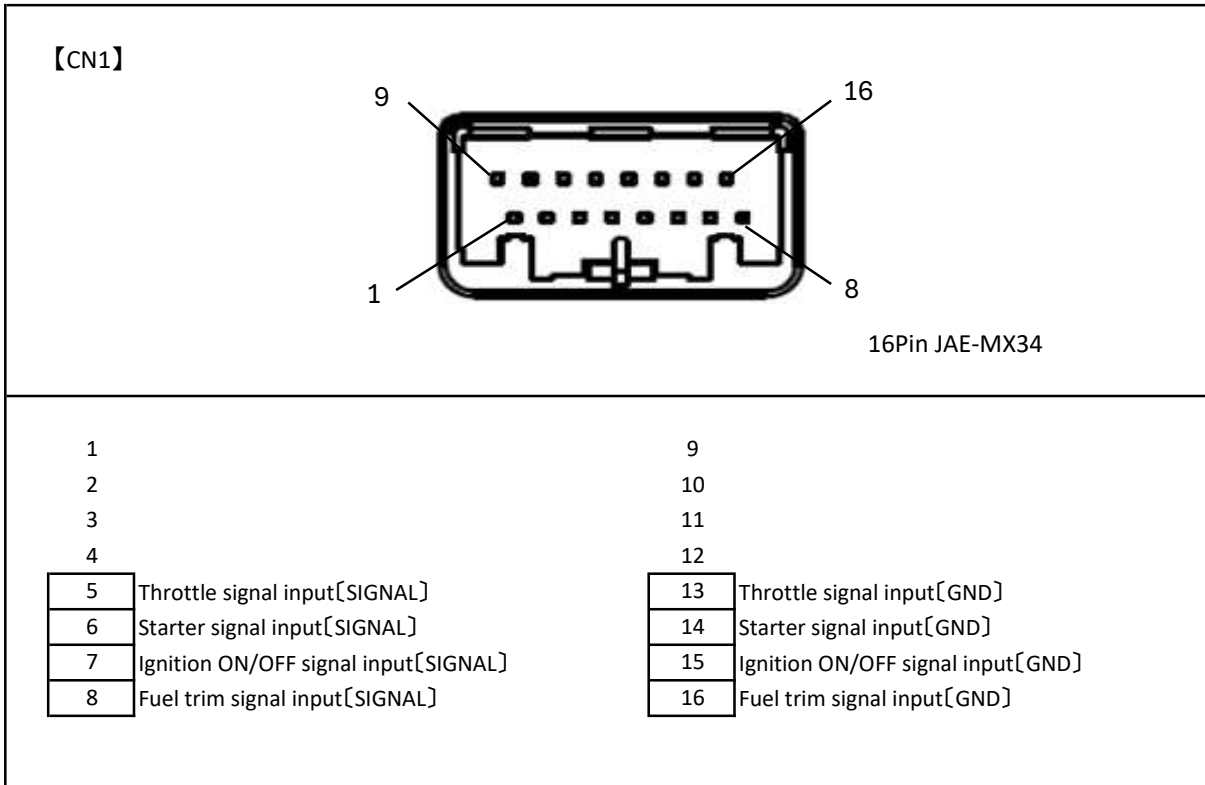

12. Assignment of the pins.

【CN2】

32Pin JAE-MX34

<table style="width: 100%; border-collapse: collapse;"> <tr><td style="border: 1px solid black; text-align: center;">1</td><td>Fuel pump[Power supply DC+12V]</td></tr> <tr><td style="border: 1px solid black; text-align: center;">2</td><td>Fuel pressure sensor[+5V]</td></tr> <tr><td style="border: 1px solid black; text-align: center;">3</td><td>Injector [Power supply DC+12V]</td></tr> <tr><td style="border: 1px solid black; text-align: center;">4</td><td>(GND)</td></tr> <tr><td style="border: 1px solid black; text-align: center;">5</td><td>Crankshaft rotation sensor[SIGNAL]</td></tr> <tr><td style="border: 1px solid black; text-align: center;">6</td><td></td></tr> <tr><td style="border: 1px solid black; text-align: center;">7</td><td>Cylinder head temperature sensor[+]</td></tr> <tr><td style="border: 1px solid black; text-align: center;">8</td><td></td></tr> <tr><td style="border: 1px solid black; text-align: center;">9</td><td>Throttle servo[SIGNAL]</td></tr> <tr><td style="border: 1px solid black; text-align: center;">10</td><td></td></tr> <tr><td style="border: 1px solid black; text-align: center;">11</td><td></td></tr> <tr><td style="border: 1px solid black; text-align: center;">12</td><td>Signal output to starter ESC [SIGNAL]</td></tr> <tr><td style="border: 1px solid black; text-align: center;">13</td><td></td></tr> <tr><td style="border: 1px solid black; text-align: center;">14</td><td></td></tr> <tr><td style="border: 1px solid black; text-align: center;">15</td><td>Ignition signal output[IOL=max7mA]</td></tr> <tr><td style="border: 1px solid black; text-align: center;">16</td><td>Power supply for igniter[DC+6V]</td></tr> </table>	1	Fuel pump[Power supply DC+12V]	2	Fuel pressure sensor[+5V]	3	Injector [Power supply DC+12V]	4	(GND)	5	Crankshaft rotation sensor[SIGNAL]	6		7	Cylinder head temperature sensor[+]	8		9	Throttle servo[SIGNAL]	10		11		12	Signal output to starter ESC [SIGNAL]	13		14		15	Ignition signal output[IOL=max7mA]	16	Power supply for igniter[DC+6V]	<table style="width: 100%; border-collapse: collapse;"> <tr><td style="border: 1px solid black; text-align: center;">17</td><td>Fuel pump[SIGNAL IOL=max1A]</td></tr> <tr><td style="border: 1px solid black; text-align: center;">18</td><td>Fuel pressure sensor[SIGNAL]</td></tr> <tr><td style="border: 1px solid black; text-align: center;">19</td><td>Fuel pressure sensor[GND]</td></tr> <tr><td style="border: 1px solid black; text-align: center;">20</td><td>Injector[SIGNAL IOL=max1A]</td></tr> <tr><td style="border: 1px solid black; text-align: center;">21</td><td>Crankshaft rotation sensor[GND]</td></tr> <tr><td style="border: 1px solid black; text-align: center;">22</td><td>Crankshaft rotation sensor[+5V]</td></tr> <tr><td style="border: 1px solid black; text-align: center;">23</td><td>Cylinder head temperature sensor[-]</td></tr> <tr><td style="border: 1px solid black; text-align: center;">24</td><td></td></tr> <tr><td style="border: 1px solid black; text-align: center;">25</td><td>Throttle servo[GND]</td></tr> <tr><td style="border: 1px solid black; text-align: center;">26</td><td>Throttle servo[Power supply DC+5V]</td></tr> <tr><td style="border: 1px solid black; text-align: center;">27</td><td></td></tr> <tr><td style="border: 1px solid black; text-align: center;">28</td><td>Signal output to starter ESC [GND]</td></tr> <tr><td style="border: 1px solid black; text-align: center;">29</td><td>Power output to starter ESC [DC+5V]</td></tr> <tr><td style="border: 1px solid black; text-align: center;">30</td><td></td></tr> <tr><td style="border: 1px solid black; text-align: center;">31</td><td>Ignition signal output[GND]※</td></tr> <tr><td style="border: 1px solid black; text-align: center;">32</td><td>(It is isolated from other than the ※mark.)</td></tr> </table>	17	Fuel pump[SIGNAL IOL=max1A]	18	Fuel pressure sensor[SIGNAL]	19	Fuel pressure sensor[GND]	20	Injector[SIGNAL IOL=max1A]	21	Crankshaft rotation sensor[GND]	22	Crankshaft rotation sensor[+5V]	23	Cylinder head temperature sensor[-]	24		25	Throttle servo[GND]	26	Throttle servo[Power supply DC+5V]	27		28	Signal output to starter ESC [GND]	29	Power output to starter ESC [DC+5V]	30		31	Ignition signal output[GND]※	32	(It is isolated from other than the ※mark.)
1	Fuel pump[Power supply DC+12V]																																																																
2	Fuel pressure sensor[+5V]																																																																
3	Injector [Power supply DC+12V]																																																																
4	(GND)																																																																
5	Crankshaft rotation sensor[SIGNAL]																																																																
6																																																																	
7	Cylinder head temperature sensor[+]																																																																
8																																																																	
9	Throttle servo[SIGNAL]																																																																
10																																																																	
11																																																																	
12	Signal output to starter ESC [SIGNAL]																																																																
13																																																																	
14																																																																	
15	Ignition signal output[IOL=max7mA]																																																																
16	Power supply for igniter[DC+6V]																																																																
17	Fuel pump[SIGNAL IOL=max1A]																																																																
18	Fuel pressure sensor[SIGNAL]																																																																
19	Fuel pressure sensor[GND]																																																																
20	Injector[SIGNAL IOL=max1A]																																																																
21	Crankshaft rotation sensor[GND]																																																																
22	Crankshaft rotation sensor[+5V]																																																																
23	Cylinder head temperature sensor[-]																																																																
24																																																																	
25	Throttle servo[GND]																																																																
26	Throttle servo[Power supply DC+5V]																																																																
27																																																																	
28	Signal output to starter ESC [GND]																																																																
29	Power output to starter ESC [DC+5V]																																																																
30																																																																	
31	Ignition signal output[GND]※																																																																
32	(It is isolated from other than the ※mark.)																																																																

12. Assignment of the pins.

【POWER SUPPLY】

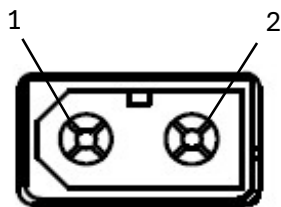

XT60

1	Power supply [GND]
2	Power supply [Vcc] Be sure to get power from a 12S (6Sx2) Li-Po battery via HUB-01.

【LED】 【S.BUS2】 【UART】

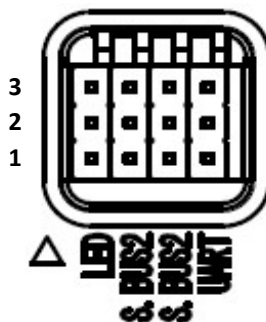

LED

3

2	Pilot lamp power output [DC+6V]
1	[GND]※ (It is isolated from other than the ※mark.)

S.BUS2 (Both terminals are connected to the same bus.)

3	[SIGNAL]
2	[DC+5V] This is a power output. Do not connect if the connected device does not require power.
1	[GND]

UART

3	[TX]
2	[RX]
1	[GND]

12. Assignment of the pins.

【CAN】

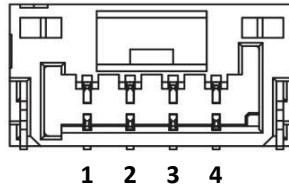

4 pin JST-GH

1	[DC+5V]
2	[CAN_H]
3	[CAN_L]
4	[GND]

【RS-485】

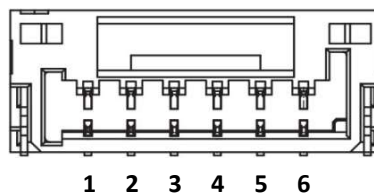

6 pin JST-GH

1	[RXD(+)]
2	[RXD(-)]
3	[TXD(-)]
4	[TXD(+)]
5	[DC+5V]
6	[GND]

13.Engine parts list

■ ENGINE PARTS LIST / GF80TU2-FI W/SGM (1/3)			
No.	Code No.	Description	
1	4B401000	CRANKCASE GF80TU	
2	74002A20	ROTATION SENSOR IG-10	
3	74002321	ROTATION SENSOR FIXING SCREW (2PCS)	
4	29730000	BALL BEARING(FR)	
5	4AL30000	BALL BEARING(FR)	
7	4AL31000	BALL BEARING(RR)	
8	45231100	CAMSHAFT BEARING (1PC)	
9	4B402000	CRANKSHAFT GF80TU2	
10	29708200	PARAREL KEY (1PC)	
11	4AL62001	CAMSHAFT(F)	
12	4AL62002	CAMSHAFT(R)	
13	4AL01100	CAM COVER (1PC)	
14	4AL01101	CAM COVER O-RING (1PC)	
15	4AL08000	DRIVE SPACER GF80TU	
16	29708100	TAPER COLLET	
17	28602100	PILOT SHAFT	
18	79872100	WASHER 10.0	
19	29709000	PROPELLER WASHER	
20	4B428000	MOUNTING PLATE GF80TU	
21	4AL81201	THROTTLE SERVO MOUNT GF80TU (1PC)	
22	4AD81221	THROTTLE SERVO	
23	4AD81401	THROTTLE SERVO HORN	
24	4AD81205	THROTTLE SERVO PLATE (1PC)	
25	4AL81202	THROTTLE LINK ROD	
26	4AL03300	CYLINDER GF80TU (1PC)	
27	29122540	SILENCER GASKET (O-RING)	
28	4B403200	PISTON GF80TU2 (1PC)	
29	49403400	PISTON RING (1PC)	
30	49406010	PISTON PIN (1PC)	
31	29717000	PISTON PIN RETAINER (2PCS)	
32	4AL04000	CYLINDER HEAD (1PC)	
33	49404160	HEAD GASKET (1PC)	
34	54056014	ST-02 TEMPERATURE SENSOR (1PC)	
35	4A004200	ROCKER COVER (1CP)	
36	44514300	ROCKER COVER GASKET (1PC)	
37	45761600	ROCKER ARM RETAINER (2PCS)	
38	49464000	ROCKER SUPPORT (1PC)	
39	4AD61100	ROCKER ARM (1PC)	
40	44561200	TAPPET ADJUSTING SCREW (1PC)	
41	45560410	COTTER PIN (2PCS/1PAIR)	
42	4AL60400	VALVE SPRING RETAINER (1PC)	
43	49460200	VALVE SPRING (1PC)	
44	49460110	POPPET VALVE (1PC)	
45	4AD66000	PUSH ROD (2PCS)	
46	45566310	PUSH-ROD COVER O-RING (2PCS)	
47	49466100	PUSH ROD COVER (1PC)	
48	44564000	CAM FOLLOWER (2PCS)	
49	4AL69401	INTAKE MANIFOLD A GF80TU	
50	4AL14010	INTAKE MANIFOLD A GASKET GF80TU	
51	4AL69402	INTAKE MANIFOLD B GF80TU (1PC)	

13.Engine parts list

■ ENGINE PARTS LIST / GF80TU2-FI W/SGM (2/3)			
No.	Code No.	Description	
52	49414010	INTAKE MANIFOLD GASKET (2PCS)	
53	4AL69403	INTAKE PIPE GF80TU (1PC)	
54	4AA07410	O-RING (1PC)	
55	4AL16100	REED VALVE MOUNT GF80TU	
56	4AL15001	REED VALVE MOUNT GASKET GF80TU	
57	4AL15002	REED VALVE GASKET GF80TU (1PC)	
58	4AL16000	REED VALVE ASSEMBLY GF80TU	
59	4B481100	THROTTLE BODY GF80TU2	
60	4AL81204	THROTTLE VALVE GF80TU	
62	4AD81400	THROTTLE ARM	
63	4AL81220	ROTOR GUIDE WASHER	
64	4AD84000	INJECTOR	
65	4AD84003	INJECTOR RING SEAL	
66	4AD84004	INJECTOR O-RING	
67	4AD84014	INJECTOR WIRE HARNESS	
68	4AD84005	INJECTOR SPACER (2PCS)	
69	4AD83300	INJECTOR COUPLER	
70	4AD81950	FUEL INLET (1SET)	
71	4AL12000	AIR CLEANER ADAPTER GF80TU	
72	4AL15003	AIR CLEANER ADAPTER GASKET GF80TU	
91	54094000	SGM-8020-185	
92	54085006	STATOR RETAINER	
93	45520000	THRUST WASHER	
94	54085007	ROTOR STOP SCREW GF80TU	
95	74003590	M5 STAND OFF ENGINE MOUNT 60mm (4PCS)	
96	55500004	NORD LOCK WASHER M5 (10PCS.)	
97	4B425000	SILENCER F-6051 (1PC)	
98	4B425003	SILENCER BODY F-6051 (1PC)	
99	4B426000	EXHAUST HEADER PIPE F-6051 (1PC)	
100	4AL24000	ALUMINUM SPINNER	
101	4AG81000	AIR CLEANER UNI (PK-4E)	
C1	79871020	HEXAGON HEAD SCREW M2.6X7 (10PCS/SET)	
C2	79871030	HEXAGON HEAD SCREW M2.6X10 (10PCS/SET)	
C3	79871110	HEXAGON HEAD SCREW M3.0X 8(10PCS/SET)	
C5	79871140	HEXAGON HEAD SCREW M3.0X12(10PCS/SET)	
C6	79871410	HEXAGON HEAD SCREW M4.0X10 (10PCS/SET)	
C7	79871415	HEXAGON HEAD SCREW M4.0X15(10PCS/SET)	
C8	79871425	HEXAGON HEAD SCREW M4.0X25(10PCS/SET)	
C9	79871430	HEXAGON HEAD SCREW M4.0X30(10PCS/SET)	
C10	79871520	HEXAGON HEAD SCREW M5.0X20(10PCS/SET)	
C11	79871525	HEXAGON HEAD SCREW M5.0X25(10PCS/SET)	
C12	79871540	HEXAGON HEAD SCREW M5.0X40 (10PCS/SET)	
C13	79875616	HEXAGON FLAT-H SCREW M6.0X16(10PCS/SET)	
E1	75009001	EC-23 ECU	
E2	75000007	MOUNT COLLAR (4PCS)	
E3	75007008	ENGINE WIRE HARNESS	
E4	75007009	PWM SIGNAL WIRE HARNESS	
E5	54067020	SC-03 CURRENT SENSOR UNIT (1PC)	
E6	74001200	LED HARNESS SET(RED)	
E7	75001014	PUMP CONNECTION CORD (50cm)	

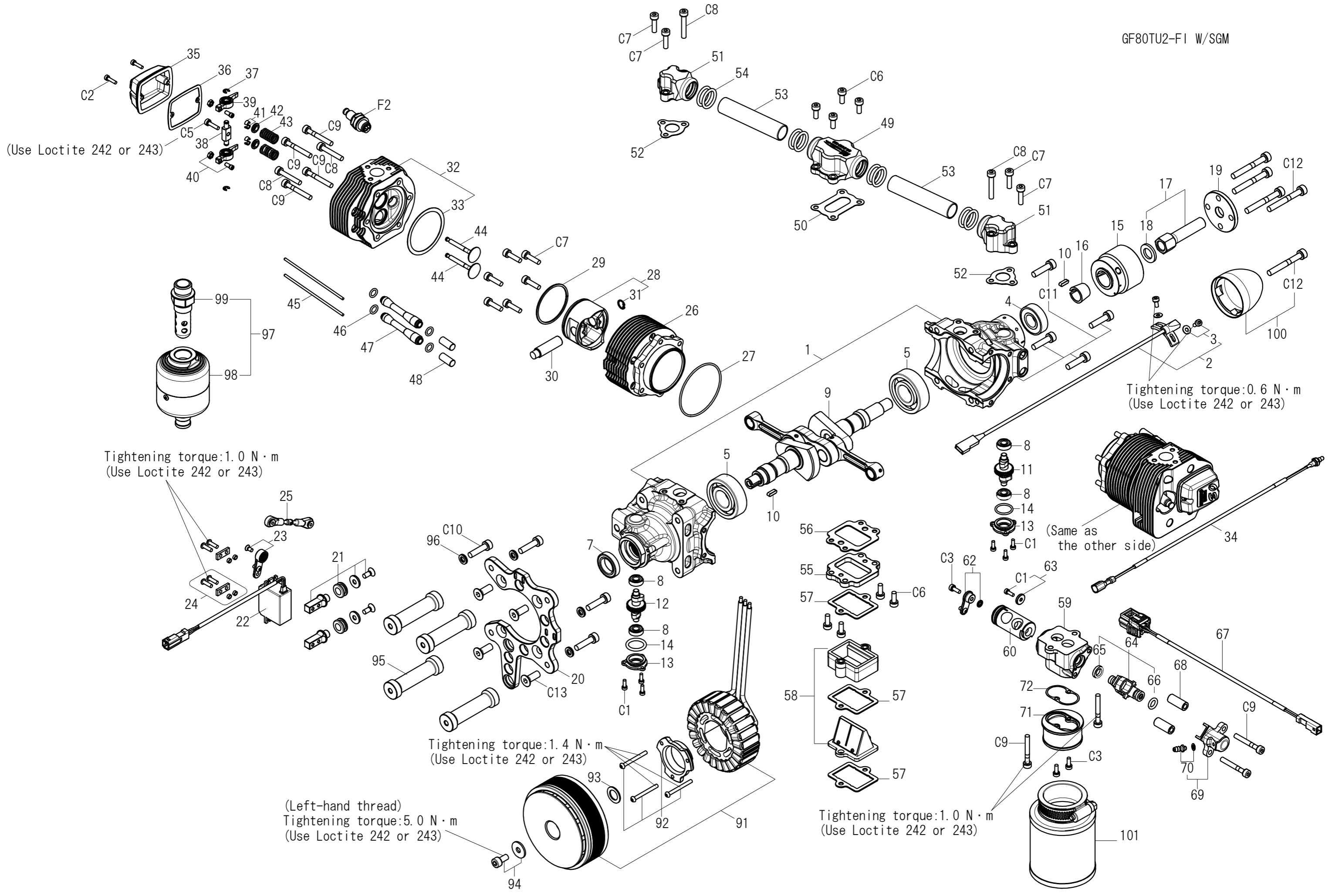

13.Engine parts list

EC-21 ENGINE CONTROL UNIT

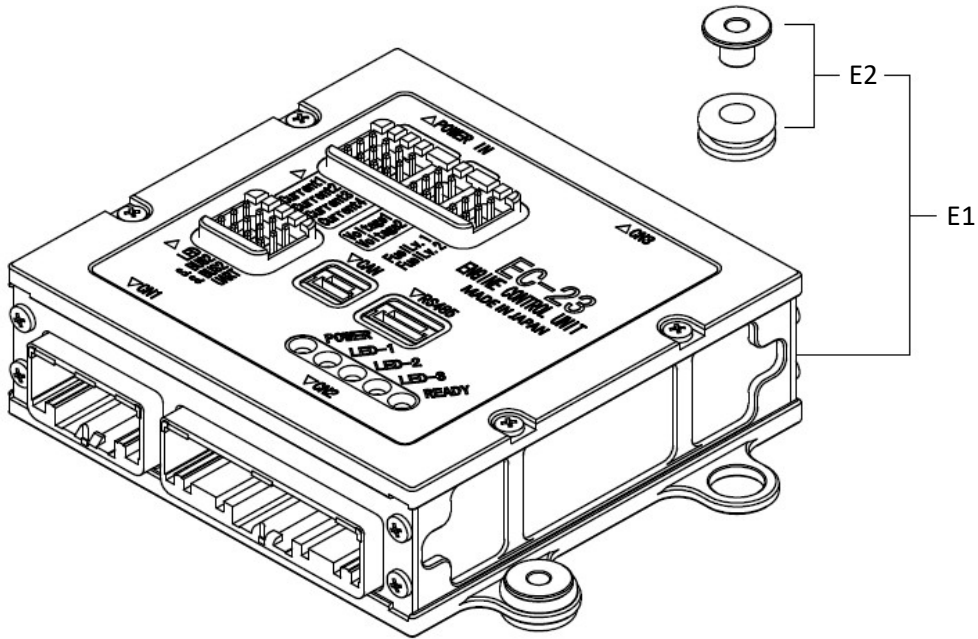

ENGINE WIRE HARNESS

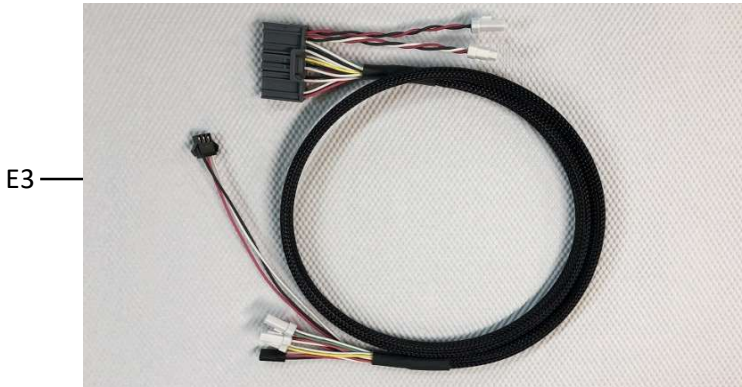

PWM SIGNAL HARNESS



SC-03 CURRENT SENSOR UNIT



LED HARNESS SET(RED)



13.Engine parts list

PUMP CONNECTION CORD (50cm)

E7



POWER SUPPLY CORD

E8



U2S-2 FOR EC-2#(SERIAL SIGNAL CONVERTER)

E9



SGC-1095HV(FOR SGM)

E10

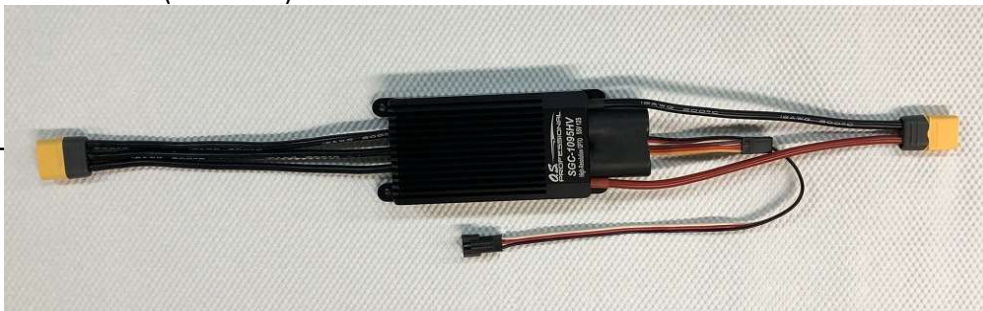

HUB-01

E11



13.Engine parts list

PM-02A FUEL PUMP UNIT

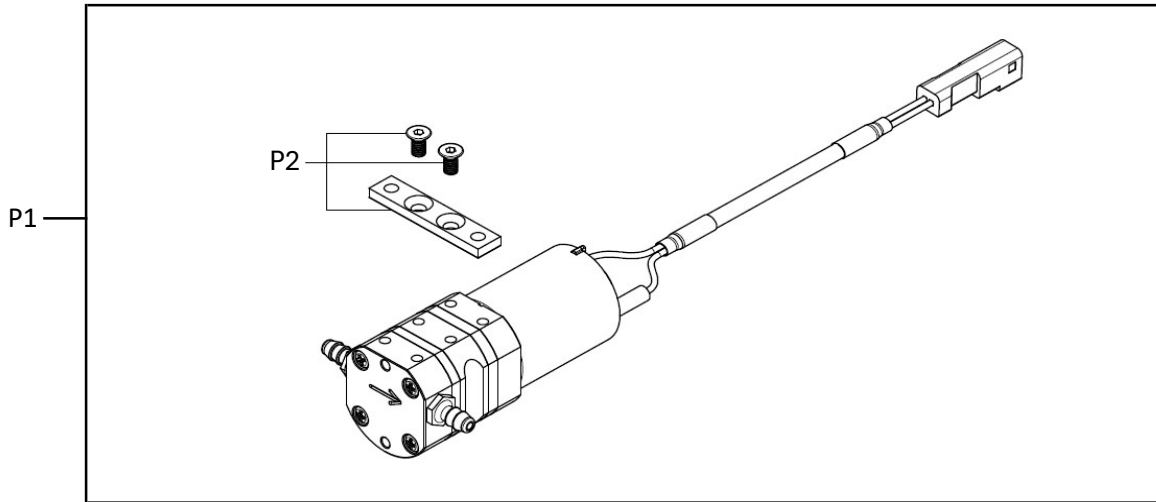

SP-01 FUEL PRESSURE SENSOR UNIT

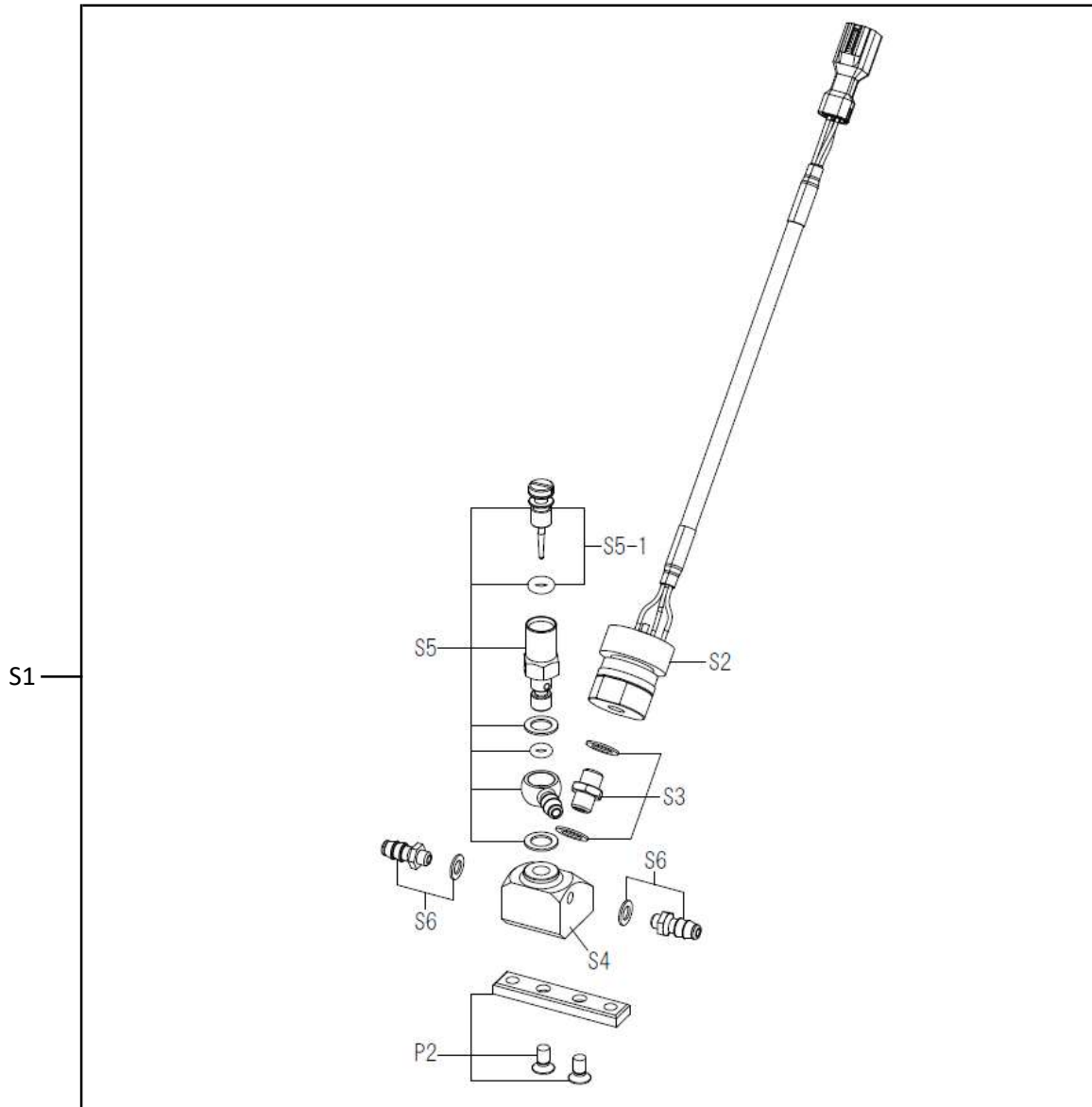

13.Engine parts list

F1 —



IGNITION MODULE (IG-14)

F2 —



SPARK PLUG CM-6(NGK)

F3 —



SOCKET WRENCH FOR TEMPERATURE SENSOR

F4 —



HOSE CLIP 6 (5pcs.)

F5 —



GASOLINE FUEL FILTER S

F6 —



NON-BUBBLE WEIGHT S

F7 —



CONNECTOR LOCK (5pcs.)

13.Engine parts list

F8—



FLUORINE(ETFE) RESIN TUBING (2m)
(EIGHTRON Flexible Fluorine (ETFE) Resin Tubing
Clear made by HAKKO CORPORATION / JAPAN)

F9—



VALVE ADJUSTING TOOL KIT GF
(Option)

F10—



VOLTAGE SENSOR(SV-01)
(Option)

F11—



FUEL SENSOR(SFL-01) 測定範囲0-100mm (※)
(Option)

F12—

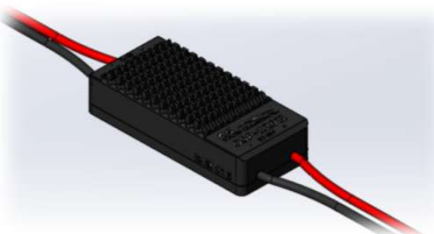

DC-DC SWITCHING REGULATOR(OSP-120II)
(Option)

Input: DC15~55V
Output: DC12.4V±5%
7A(MAX10A/30sec)

14. Measurements

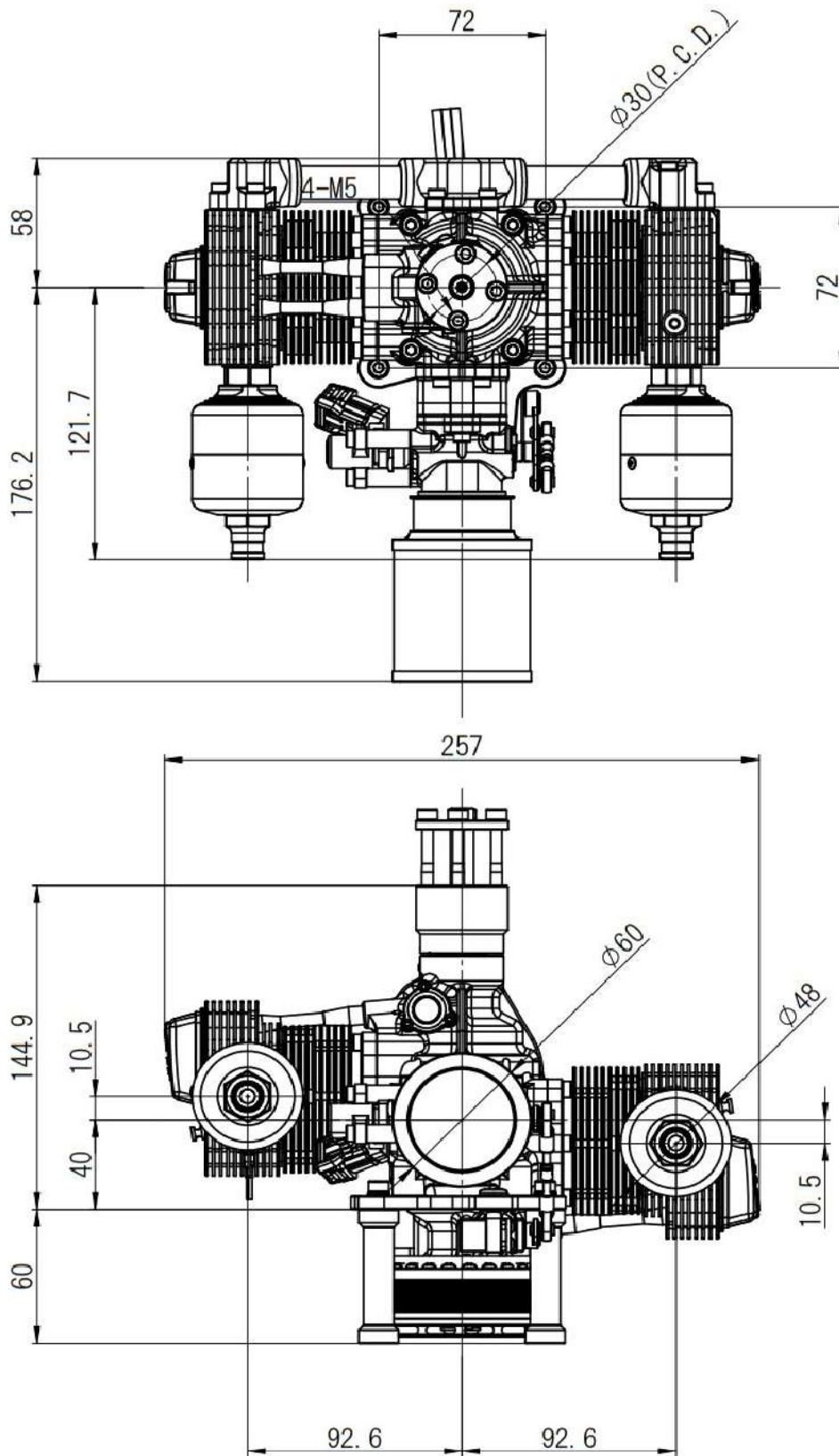

GF80TU2-FI with SGM-8020

Unit : mm

14. Measurements

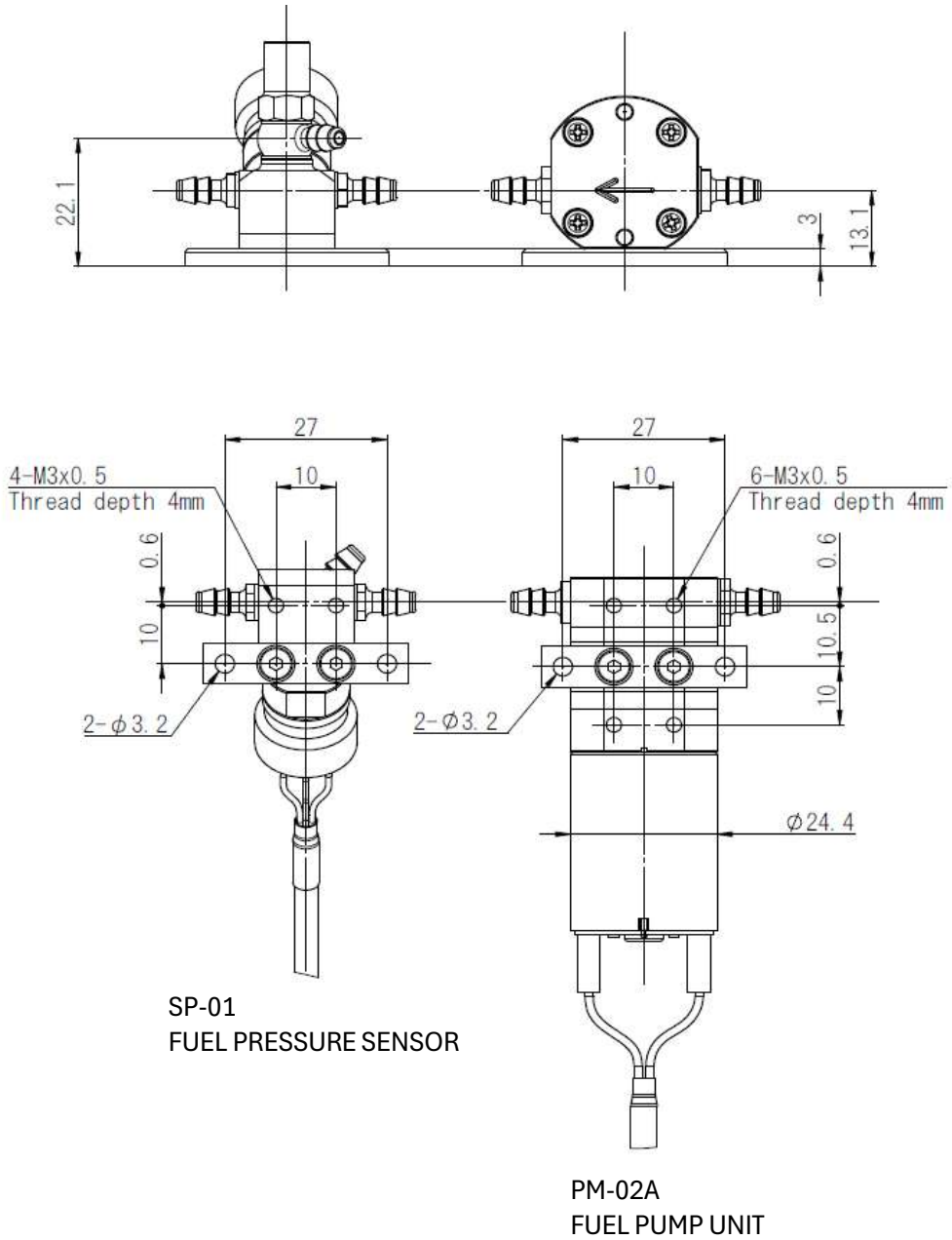

Unit : mm

14. Measurements

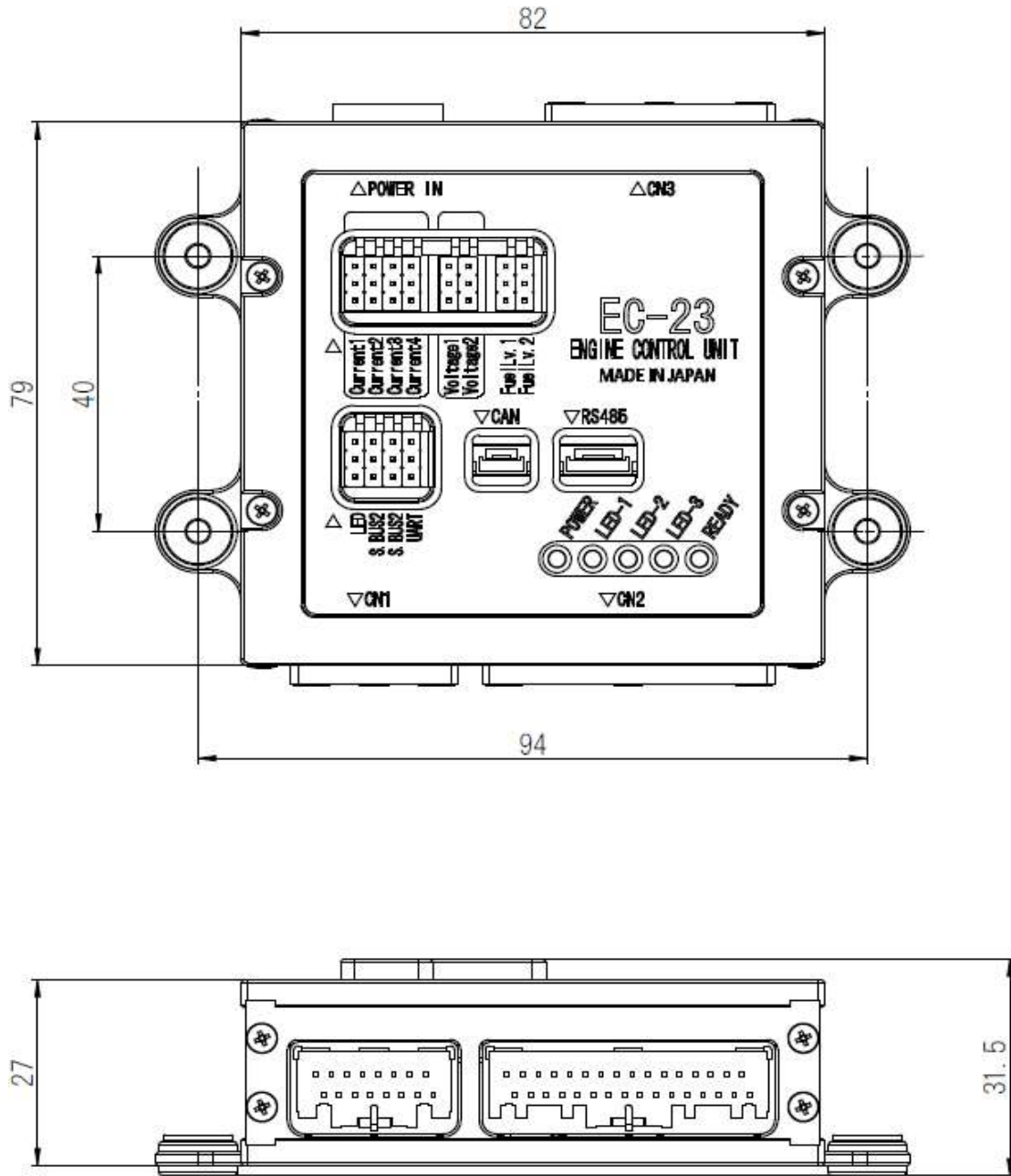

EC-23
ENGINE CONTROL UNIT

Unit : mm

14. Measurements

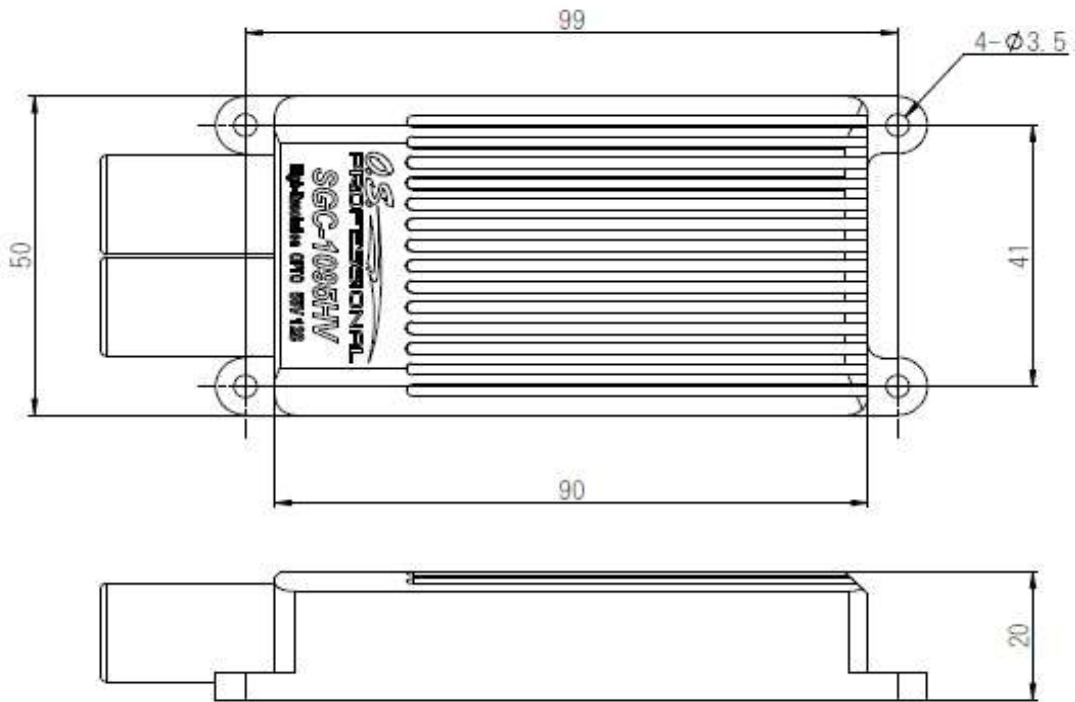

SGC-1095HV
SGC(ESC)

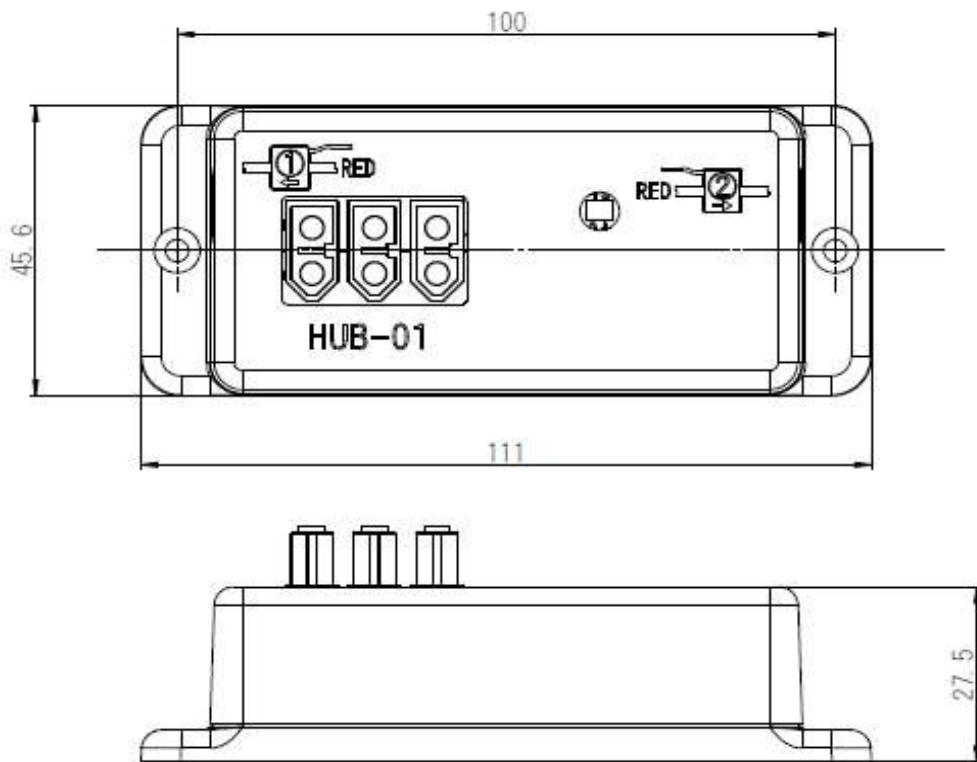

HUB-01
Power distribution box with fuse

Unit : mm

MEMO

O.S. ENGINES MFG.CO.,LTD.

6-15 3-Chome Imagawa Higashisumiyoshi-ku

Osaka 546-0003, Japan

TEL.+81-6-6702-0225

FAX.+81-6-6704-2722

<http://www.os-engines.co.jp>