

O.S. ENGINE MAX-18CV-R Blue Head Series

OWNER'S INSTRUCTION MANUAL

It is of vital importance, before attempting to operate your engine, to read the general '**SAFETY INSTRUCTIONS AND WARNINGS**' section on pages 2-5 of this booklet and to strictly adhere to the advice contained therein.

- Also, please study the entire contents of this instruction manual, so as to familiarize yourself with the controls and other features of the engine.
- Keep these instructions in a safe place so that you may readily refer to them whenever necessary.
- It is suggested that any instructions supplied with the vehicle, radio control equipment, etc., are accessible for checking at the same time.

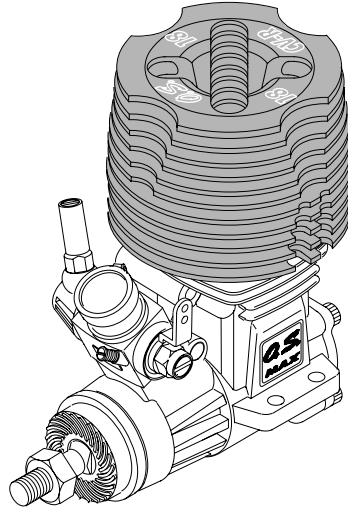

CONTENTS

SAFETY INSTRUCTIONS AND WARNINGS ABOUT YOUR O.S. ENGINE	2-5	FINAL ADJUSTMENT	23-24
ENGINE CONSTRUCTION, NOTES WHEN APPLYING AN ELECTRIC STARTER	6-7	CARBURETOR CLEANLINESS, CARE AND MAINTENANCE	25-27
INSTRUCTIONS, TOOLS, ACCESSORIES, etc.	8-10	CHECKING THE ENGINE, TROUBLE SHOOTING	27-31
BASIC ENGINE PARTS, CARBURETOR CONTROLS (11G), (11J)	11-12	EXPLODED ENGINES VIEWS & PARTS LIST	32-37
INSTALLATION NOTES CONCERNING THE RECOIL STARTER	13-14	CARBURETOR EXPLODED VIEW & PARTS LIST	38-41
SUPER AIR CLEANER 202, 203	15-17	O.S. GENUINE PARTS & ACCESSORIES	42
GLOWPLUG, PRESSURIZED FUEL SYSTEM	18-19	THREE VIEW DRAWING,	43-45
STARTING THE ENGINE & RUNNING-IN ('Breaking-in)	20-23	MEMO	46

SAFETY INSTRUCTIONS AND WARNINGS ABOUT YOUR O.S. ENGINE

Remember that your engine is not a "toy", but a highly efficient internal-combustion machine whose power is capable of harming you, or others, if it is misused.





As owner, you, alone, are responsible for the safe operation of your engine, so act with discretion and care at all times.

If at some future date, your O.S. engine is acquired by another person, we would respectfully request that these instructions are also passed on to its new owner.

■ The advice which follows applies basically to ALL MODEL ENGINES and is grouped under two headings according to the degree of damage or danger which might arise through misuse or neglect.

 WARNINGS
<p>These cover events which might involve serious (in extreme circumstances, even fatal) injury.</p>

 NOTES
<p>These cover the many other possibilities, generally less obvious sources of danger, but which, under certain circumstances, may also cause damage or injury.</p>

 WARNINGS	
<ul style="list-style-type: none"> • Model engine fuel is poisonous. Do not allow it to come into contact with the eyes or mouth. Always store it in a clearly marked container and out of the reach of children. <div style="text-align: right; margin-top: 10px;">  </div> • Model engine fuel is also highly flammable. Keep it away from an open flame, excessive heat, sources of sparks, or anything else which might ignite it. Do not smoke or allow anyone else to smoke, near to it. <div style="text-align: right; margin-top: 10px;">  </div> 	<ul style="list-style-type: none"> • Never operate your engine in an enclosed space. Model engines, like automobile engines, exhaust deadly carbon-monoxide. Run your engine only in an open area. • Model engines generate considerable heat. Do not touch any part of your engine until it has cooled. Contact with the muffler (silencer), cylinder head or exhaust header pipe, in particular, may result in a serious burn. <div style="text-align: right; margin-top: 10px;">  </div>



NOTES

- This engine is intended for model cars. Do not attempt to use it for any other purpose.
- Mount the engine in your model securely, following the manufacturer's recommendations, using appropriate screws and locknuts.
- Install an effective silencer (muffler). Frequent close exposure to a noisy exhaust (especially in the case of the more powerful highspeed engines) may eventually impair your hearing and such noise is also likely to cause annoyance to others over a wide area.
- The wearing of safety glasses is also strongly recommended.
- Take care that the glowplug clip or battery leads do not come into contact with rotating parts. Also check that the linkage to the throttle arm is secure.
- For their safety, keep all onlookers (especially small children) well back (at least 20 feet or 6 meters) when preparing your model for running.
- Before starting the engine, always check the tightness of all the screws and nuts especially those of joint and movable parts such as throttle arm. Missing retightening the loose screws and nuts often causes the parts breakage that is capable of harming you.



NOTES

- To stop the engine, fully retard the throttle stick and trim lever on the transmitter, or, in an emergency, cut off the fuel supply by pinching the fuel delivery line from the tank.
- Do not attempt to disassemble the recoil starter of the 18CV-RX. If you do so, the very strong spring inside will be suddenly ejected. This can be very dangerous.
- Do not extend the starter cord more than 45cm (18"). Do not abruptly release the operating handle. Allow the cord to rewind smoothly while still holding the handle.
- Pull the operating handle straight out when starting the engine, so that the cord does not rub against the vehicle body or engine. This will help prevent the cord from being damaged by abrasion or engine heat.
- Warning! Immediately after a glowplug-ignition engine has been run and is still warm, conditions sometimes exist whereby it is just possible for the engine to abruptly restart if it is rotated over compression WITHOUT the glowplug battery being reconnected.

ENGINE CONSTRUCTION

With this engine, the piston will feel tight at the top of its stroke (TDC) when the engine is cold. This is normal.

The cylinder bore has a slight taper.

The piston and cylinder are designed to achieve a perfect running clearance when they reach operating temperature.

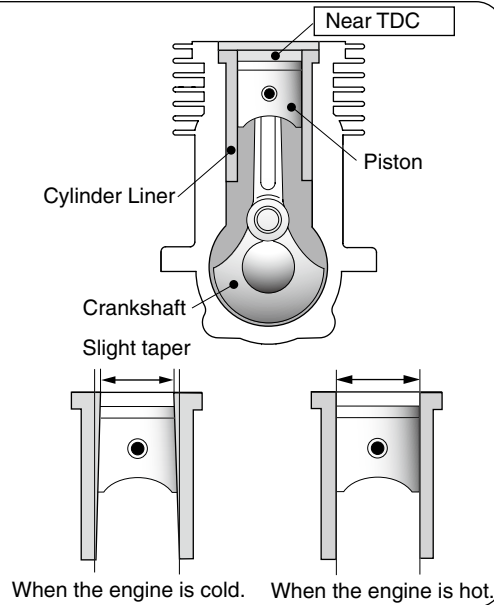

6

NOTES WHEN APPLYING AN ELECTRIC STARTER

Do not over-prime. This could cause a hydraulic lock and damage the engine on application of the electric starter.

If over-primed, remove glowplug, close needle-valve and apply starter to pump out surplus fuel. Cover the head with a rag to prevent pumped out fuel getting into your eyes.

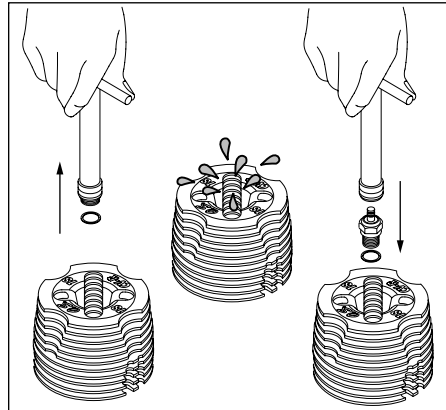

NOTE

As delivered, the engine has the carburetor lightly fit into its intake. Secure it changing its angle according to the car chassis.

7

MAX-18CV-R BLUE HEAD SERIES INSTRUCTIONS

This manual handles the following three versions.

MAX-18CV-R (P) with 11G carburetor

MAX-18CV-R with 11J carburetor

MAX-18CV-RX with 11J carburetor

The MAX-18CV-R and MAX-18CV-RX are high-performance engines for 1/10 class stadium trucks, off-road vehicles and sport cars. There are two versions, the one with 11G carburetor and the other with 11J carburetor.

Standard accessories

- Glow Plug No.8
- Super Air Cleaner 203 Assembly
- Super Air Cleaner 202 Assembly(for 18CV-R(P))
- Engine Mount Spacer (for 18CV-RX)
- Instruction manual

8

About the Head Gasket

These engines are equipped with two head gaskets of 0.1mm thick and 0.2mm thick. It is suggested to adjust the total thickness according to atmospheric temperature, humidity and glowplug used.

- At early stage of running-in, when a glowplug tends to burn out early or when high nitromethane content fuel is used, try to run the engine with both gaskets.
- When low nitromethane content fuel is used, try to run the engine removing the 0.1mm gasket.

TOOLS, ACCESSORIES, etc.

The following items are necessary for operating the engine.

■ Items necessary for starting

FUEL

Generally, it is suggested that the user selects a fuel that is commercially available for model two-stroke engines and contains 10-30% nitromethane. As a starting point, we recommend a fuel containing 20% nitromethane, changing to a fuel containing more nitro if necessary. When the brand of fuel is changed, or the nitro content increased, it is advisable to repeat the running-in procedure referred to in the RUNNING-IN paragraphs. Please note that with high-nitro fuels, although power may be increased for competition purposes, glowplug elements do not last as long and engine life will be shortened.

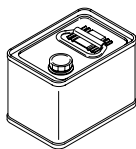

REMINDER!

 Model engine fuel is poisonous. Do not allow it to come into contact with the eyes or mouth. Always store it in a clearly marked container and out of the reach of children.

 Model engine fuel is also highly flammable. Keep it away from open flame, excessive heat, sources of sparks, or anything else which might ignite it. Do not smoke or allow anyone else to smoke, near to it.

FUEL FILTER

Should be installed in the fuel line between fuel tank and carburetor to prevent foreign matter from entering the carburetor.

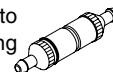

GLOWPLUG IGNITER

Commercially available handy glowplug heater in which the glowplug battery and battery leads are integrated.

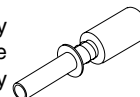

9

STARTER BOX

For starting the engine. It is not necessary for the recoil starter version-i.e. 18CV-RX.

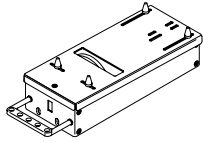

7.2V BATTERIES FOR STARTER BOX

Batteries for starter box. Select according to the starter box used. Be sure to full charge before using.

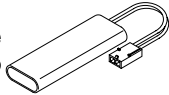

FUEL PUMP

For filling the fuel tank, a simple, polyethylene "squeeze" bottle, with a suitable spout, is required.



SILICONE FUEL LINE

Heatproof silicone tubing of approx. 5mm o.d. and 2mm i.d. is required for the connection between the fuel tank and engine.

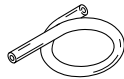

TOOLS

HEX SCREWDRIVER

Necessary for engine installation. 1.5mm, 2mm, 2.5mm, 3mm



SCREWDRIVER

Necessary for carburetor adjustments. No.1, No.2, etc

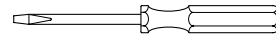

LONG SOCKET WRENCH WITH PLUG GRIP

Recommended for easy removal and replacement of the angled and recessed glowplug, the O.S. Long Socket Wrench incorporates a special grip.

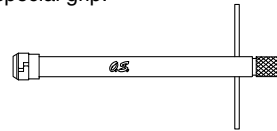

BASIC ENGINE PARTS

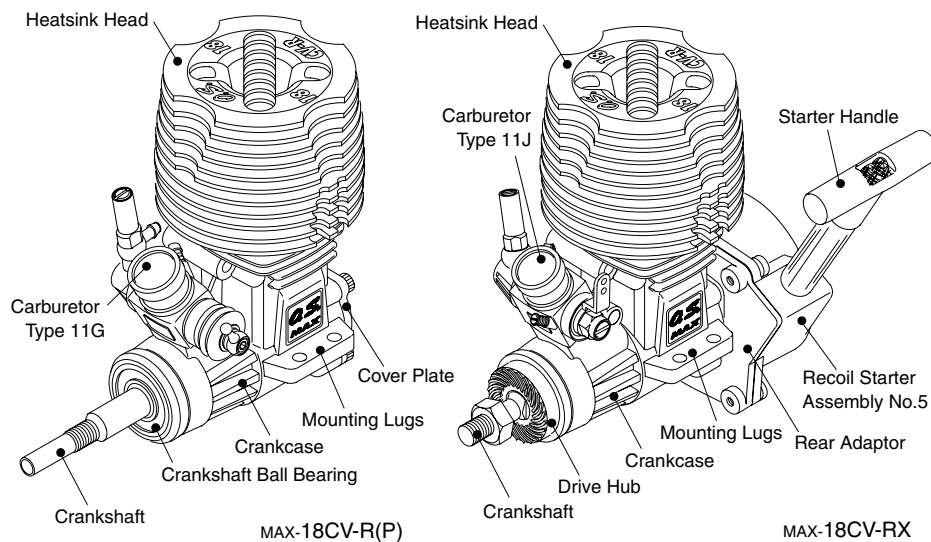

CARBURETOR CONTROLS (11G)

Three adjustable controls are provided on this carburetor.

- **The Needle-Valve:**

For adjusting the mixture strength when the throttle is fully open.

- **The Mixture Control Valve:**

For adjusting the mixture strength at part-throttle and idle speed, to obtain steady idling and smooth acceleration to mid speeds.

- **The Throttle Stop Screw:**

For setting the minimum idle speed.

NOTE:

Readjustment may be necessary, occasionally to allow for changes in fuel formula, gear ratio or clutch engagement point.

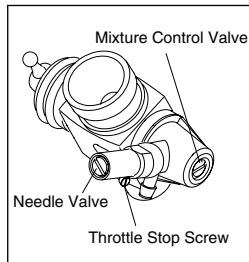

CARBURETOR CONTROLS (11J)

Three adjustable controls are provided on this carburetor.

- **The Needle-Valve:**

For adjusting the mixture strength when the throttle is fully open.

- **The Mixture Control Screw:**

For adjusting the mixture strength at part-throttle and idle speed, to obtain steady idling and smooth acceleration to mid speeds.

- **The Throttle Stop Screw:**

For setting the minimum idle speed:

NOTE:

Readjustment may be necessary, occasionally to allow for changes in fuel, gear ratio or clutch engagement point.

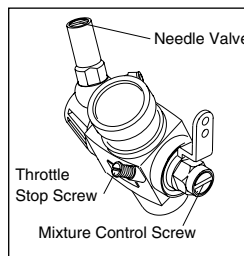

INSTALLATION OF THE CARBURETOR

As delivered, the engine has its carburetor lightly installed into the intake boss. Secure it as follows.

1. Loosen the retainer screw, rotate the carburetor to its correct position and make sure that it is pressed well down into the intake boss, compressing the rubber gasket, before retightening screw.
2. Rotate the retainer screw gently until it stops, then tighten a further 60-90°. Do not overtighten the screw as this will damage the carburetor body.

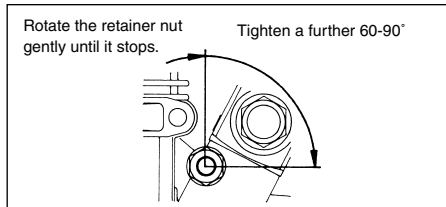

ENGINE INSTALLATION

Make sure that the vehicle's engine mounting surfaces are level and in the same plane. Poor installation may cause distortion of the crankcase, bearings, etc., resulting in erratic running and loss of performance.

The recommended screws for securing the engine are 3mm or 4-40 steel Allen hexagon socket type.

If existing holes in the engine mount do not align perfectly with engine mounting lugs, enlarge them slightly with a needle-file so that screws enter vertically.

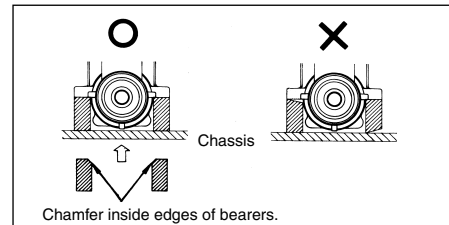

Avoid forcing the screws. Secure with locknuts. If the bottom of the recoil starter housing would otherwise touch the car chassis, install the engine mount spacers (supplied) between the engine's mounting lugs and the engine mount. Use the M3x15 screws provided. With some vehicles, it may be necessary to make minor trimming modifications to chassis or body when installing the engine.

NOTE:

When spacers are supplied joined in pairs (see sketch) separate them as shown. Either face may be placed downwards.

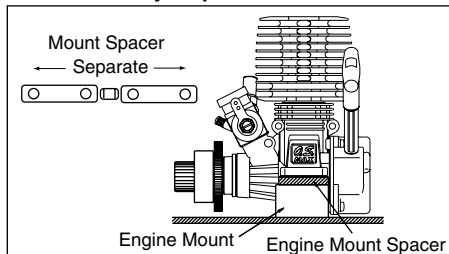

NOTES CONCERNING THE RECOIL STARTER

(18CV-RX ONLY)

REMINDER!

- ◆ Do not attempt to disassemble the recoil starter. If you do so, the very strong spring inside will be suddenly ejected. This can be very dangerous.
- ◆ Do not extend the starter cord more than 45cm (18"). Do not abruptly release the operating handle. Allow the cord to rewind smoothly while still holding the handle.
- ◆ Pull the operating handle straight out when starting the engine, so that the cord does not rub against the vehicle body or engine.
- ◆ This will help prevent the cord from being damaged by abrasion or engine heat.
- ◆ Try to avoid spilling fuel over the starter unit and its cord. Some fuels have a detrimental effect on these parts.
- ◆ The starter prevents the engine from being rotated in the wrong direction. The unit will be damaged if you attempt to force the flywheel in the opposite direction (i.e. clockwise when viewed from the crankshaft end).

AIR CLEANER TYPE 202

It has a single filter element and is intended primarily for circuit racing.

The lower height of the Super Air-Cleaner 202 also facilitates easier installation in cars where available space may be restricted.

INSTALLATION OF AIR CLEANER

- Carefully clean the carburetor, removing any old adhesive or sealant that may have been previously used on the outside of the air intake.
- Press the air cleaner body firmly over the carburetor air intake. Make sure that the outer rim of the air intake engages the internal annular groove in the air cleaner: failure to do so may result in the air cleaner falling off.
- Position the air cleaner correctly, so that it does not interfere with the cylinder-head or obstruct the needle-valve.

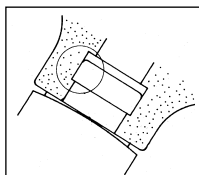

INSTALLING THE FILTER ELEMENT

- The element is already impregnated with a special filter oil. As this oil is very sticky, take care, when handling it, to prevent dust or dirt from adhering to the element. If your fingers become contaminated, wash them with soap and water.

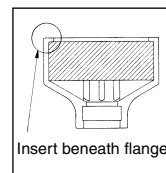

- During storage, the oil may have become unevenly dispersed through the element. This will be indicated if the blue colour of the element material appears patchy. In this case, place the element in a small plastic bag and gently rub it between finger and thumb to redistribute the oil.

REPLACEMENT OF ELEMENT

- It is advisable to replace the filter element with a new one after not more than one hour of running time. Always remove contaminated elements carefully, to ensure that dirt cannot enter the carburetor.

AIR CLEANER TYPE 203

This is a heavy-duty wet type air cleaner that has been developed specifically for 3.5cc 'off-road' model car engines. It is more compact than the former O.S. SUPER AIR CLEANER 202 and this makes it easier to install within a car body.

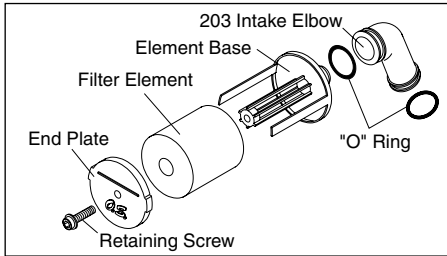

NOTE:

The element is already impregnated with a special filter oil. As this oil is very sticky, take care, when handling it, to prevent dust or dirt from adhering to the element. If your fingers become contaminated, wash them with soap and water.

ASSEMBLY

- Insert the filter element on the element base.
- Install the end plate with retaining screw, making sure that the element fits correctly between the end plate and base.
- Insert the joint pipe on the element base and secure it with "O" ring.
- Install the end plate, retaining screw, making sure that the element fits correctly between the end plate and base.

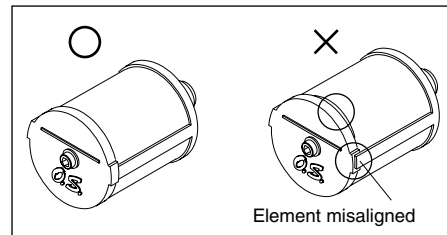

16

REPLACEMENT OF ELEMENT

NOTE:

During storage, the oil may have become unevenly dispersed through the element. This will be indicated if the blue color of the element material appears patchy. In this case, place the element in a small plastic bag and gently rub the element between finger and thumb to redistribute oil.

- It is advisable to replace the filter element after each hour of running time. Be careful not to allow dirt and dust to enter the carburetor.

INSTALLATION

- Carefully clean the carburetor, removing any old adhesive or sealant that may have been previously used on the outside of the air intake.

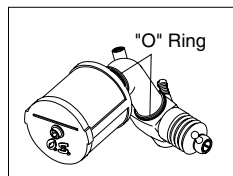

FURTHER PRECAUTIONS

When removing the air cleaner, check the inside of the element base and carburetor venturi. If any dirt is detected, this indicates that the filter element was incorrectly installed or should have been replaced earlier. In this event, it is vitally important to wash out the inside of the engine thoroughly, with alcohol or fuel, before it is used again, otherwise rapid wear of the piston/cylinder assembly, bearings, connecting-rod, etc., will occur. Obviously, it will be necessary to carry out the same procedure with the air cleaner and to replace the filter element.

NOTE:

Be careful not to splash alcohol or fuel over the filter element, or the filter oil will be washed away, and the filter capacity will be lowered.

17

GLOWPLUG

Since the glowplug and fuel combination used may have a marked effect on performance and reliability, it would be worthwhile to experiment with different plug types. An O.S. No.8 glowplug is supplied with the engine. Other Recommended O.S. plugs are A5 and R5. Carefully install plug finger-tight, before final tightening with the correct size plug wrench.

The role of the glowplug

With a glowplug engine, ignition is initiated by the application of a 1.5-volt power source. When the battery is disconnected, the heat retained within the combustion chamber remains sufficient to keep the plug filament glowing, thereby continuing to keep the engine running. Ignition timing is 'automatic': under reduced load, allowing higher rpm, the plug becomes hotter and, appropriately, fires the fuel/air charge earlier; conversely, at reduced rpm, the plug becomes cooler and ignition is retarded.

Glowplug life

Particularly in the case of very high performance engines, glowplugs must be regarded as expendable items.

However, plug life can be extended and engine performance maintained by careful use, i.e.:

- Install a plug suitable for the engine.
- Use fuel containing a moderate percentage of nitromethane unless more is essential for racing events.
- Do not run the engine too lean and do not leave the battery connected while adjusting the needle.

When to replace the glowplug

Apart from when actually burned out, a plug may need to be replaced because it no longer delivers its best performance, such as when:

- Filament surface has roughened and turned white.
- Filament coil has become distorted.
- Foreign matter has adhered to filament or plug body has corroded.
- Engine tends to cut out when idling.
- Starting qualities deteriorate.

18

PRESSURIZED FUEL SYSTEM

- The somewhat violent changes of vehicle attitude that occur in off-road running, combined with the fact that, in buggy type cars, the fuel tank is often located some distance from the carburetor, means that fuel 'head' at the carburetor can vary and upset running. Therefore, it is recommended that a muffler pressurized fuel feed system be used.
- Never run your vehicle without installing the air cleaner. Dust and dirt that may otherwise be drawn into the engine will rapidly shorten its life.



Before starting the engine, always check the tightness of all the screws and nuts especially those of joint and movable parts such as throttle arm. Missing retightening the loose screws and nuts often causes the parts breakage that is capable of harming you.

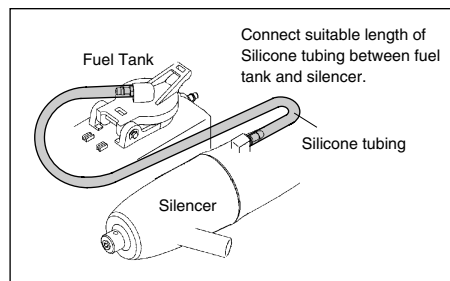

19

STARTING THE ENGINE & RUNNING-IN ('Breaking-in')

The following procedure is suitable for these engines when the O.S. T-1040 tuned silencer and a fuel containing up to 30% nitromethane are used.

- ◆ Fill the tank completely with fuel.
- ◆ Temporarily remove the glowplug to check that it glows bright red when energized.

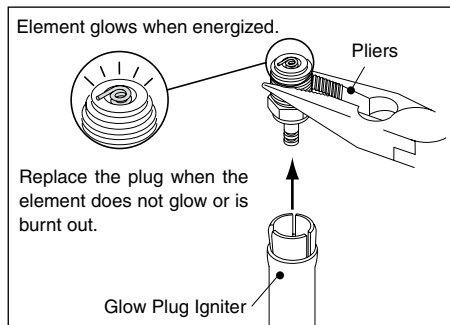

- ◆ Turn the needle-valve clockwise slowly until it stops. This is the fully closed position. Do not force to turn further.

- ◆ Open the Needle-Valve 2 turns from the fully closed position.

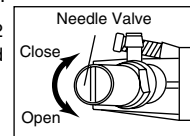

- ◆ In case of the 11G carburetor

- Set the throttle-stop screw so that the minimum throttle opening (idle setting) is approximately 0.3-0.5mm.

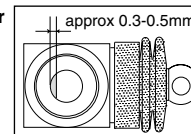

- ◆ In case of the 11J carburetor

- Set the throttle-stop screw so that the minimum throttle opening (idle setting) is approximately 1.0mm.

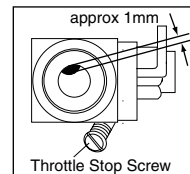

20

- ◆ Switch on the transmitter and make sure that each linkage moves correctly.
- ◆ Turn the engine with starter box to draw fuel into the engine.

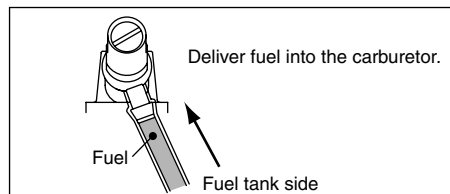

- Pull the starter handle briskly straight out several times to start the engine.

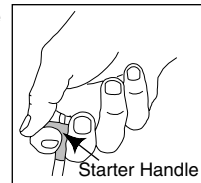

- ◆ Now connect glowplug battery lead to heat the plug filament and start the engine.
- ◆ Start the engine using a starter box, making sure the engine rotation direction is correct (counter-clockwise seen from the crankshaft end). Be sure to install an air cleaner when starting.

■ In case of the 18CV-RX

- Push the choke button on the fuel tank several times to deliver the fuel to the carburetor. (Do not over-prime or the recoil starter cannot be pulled.)

- ◆ When the engine starts, first allow it to operate in short runs at the very rich starting settings, with the glowplug battery still connected and the driving wheels clear of the ground. The rich mixture will, under these conditions, provide adequate lubrication and cooling, indicated by profuse smoke from the exhaust.

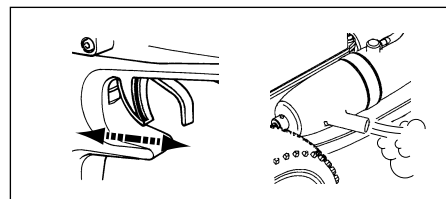

21

Remember!

It is vitally important to set the throttle at the correct position before attempting to start the engine. If the engine is allowed to run with the throttle too far open under "no load" conditions, it will rapidly overheat and may be seriously damaged.

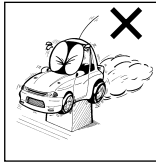

- ◆ Next, disconnect the glowplug battery and try running the car on the track. If the engine stalls, open the throttle fractionally, but try to keep the engine running as rich as possible: if it stops because of being excessively over-rich, close the Needle-Valve 30° and try again.
- ◆ Run the car on the track until one tank of fuel has been consumed, then close the Needle-Valve 30° and run the car for another full tank of fuel. Repeat this procedure until 5 more tanks of fuel have been consumed, during which time the throttle may be opened for brief bursts of increased power. If the engine stops at medium speeds, close the Mixture Screw 45-90°.

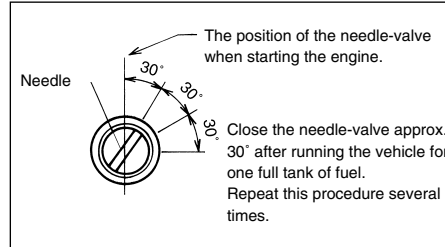

- ◆ To stop the engine, close the throttle to idling speed, then shut it off completely with the trim lever on the transmitter. To cut off the fuel supply, pinch the fuel delivery line to the carburetor.

Remember!

If the engine should need to be disassembled (e.g. for cleaning or minor parts replacement) it is advisable to return the Needle-Valve to the original rich, starting setting and check whether further running-in time is required before the car is raced again. In the event of any major working parts (e.g. piston/cylinder liner assembly) being replaced, the complete running-in should be repeated.

- ◆ To stop the engine, close the throttle to idle speed, then shut it off completely with the trim lever on the transmitter. To cut off the fuel supply, pinch the fuel delivery tube to the carburetor.

Warning!

Do not touch rotating parts, engine and silencer when stopping the engine as they become very hot, and contact with them may result in a serious burn.

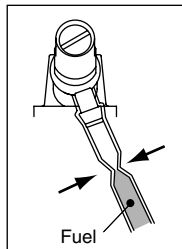

FINAL ADJUSTMENT

- ◆ Run the vehicle (with throttle fully open) over the longest available straight course, in order to observe the model's speed. Next return the car to the starting point, close the Needle-Valve 30° and repeat the run, taking note of the improvement in performance. Continue with further runs, gradually reducing the Needle-Valve setting and aiming to achieve the highest straight-line speed. Remember, however, that, if the Needle-Valve is shut down too far, the engine will overheat and, accompanied by visibly diminished exhaust smoke, the model will lose speed. At this point, throttle down immediately, stop the vehicle and reopen the Needle-Valve 30°.
- ◆ Having established the optimum Needle-Valve setting, check the Mixture Control Valve setting as follows.
- ◆ With the engine running, close the throttle and allow it to idle for about five seconds, then reopen the throttle fully. If, at this point, the engine puffs out an excessive amount of smoke and the vehicle does not accelerate smoothly and rapidly, it is probable that the idle mixture is too rich.

- ◆ In this case, turn the Mixture Control Valve clockwise 45-90°. If, on the other hand, the engine tends to speed up momentarily and then cut out abruptly when the throttle is opened, the idle mixture is too lean. Correct this by turning the Mixture Control Valve counter-clockwise 45-90°.

NOTE:

Mixture Control Valve adjustment should be made in steps of not more than 45-90°, carefully checking the effect, on throttle response, of each small adjustment.

- ◆ Carry out adjustments patiently, under actual running conditions, until the engine responds quickly and positively to the throttle control.

Warning!

Mixture adjustments (whether via the Mixture Control Valve, or the Needle-Valve) cannot be made accurately under 'no-load' conditions, which, in any case, are not advised, since such operation carries the risk of seriously damaging the engine through over-revving and overheating.

- ◆ With the optimum mixture control position, light smoke is visible during high speed running, and the engine rpm increases smoothly during acceleration. Remember that, if the engine is operated with the fuel/air mixture slightly too lean, it will overheat and run unevenly. As with all engines, it is advisable to set both needle-valve and mixture control screw very slightly on the rich side of the best rpm setting, as a safety measure.

- ◆ If the engine runs too fast with the throttle closed, the throttle stop screw should be turned counter-clockwise to allow the throttle opening to be reduced.

- ◆ Finally, beyond the nominal break-in period, a slight readjustment toward a leaner needle setting may be required to maintain performance.

CARBURETOR CLEANLINESS

The correct functioning of the carburetor depends on its small fuel orifices remaining clear.

■ BALL LINK AND SLIDE VALVE EXTENSION (In case of the 11G carburetor)

It is seldom necessary to separate the slide-valve extension from the slide-valve itself. For cleaning, withdraw this complete sub-assembly from the carburetor body after removing the slide-valve guide screw. Then wash with methanol or glow-fuel.

(Note: take care not to lose the guide screw; it is a special one.) When it is necessary to adjust the ball-link position, loosen the ball-link retaining screw with a 3mm hexagon key, re-align the ball-link and re-tighten the screw firmly.

■ REALIGNMENT OF MIXTURE CONTROL VALVE

In the course of making carburetor adjustments, it is just possible that the Mixture Control Valve may be inadvertently screwed in or out too far and thereby moved beyond its effective adjustment range. Its basic position can be found by first rotating the Mixture Control Valve until its slotted head is flush with the carburetor body. The valve is then screwed in exactly 1.5 turns to re-establish its neutral position.

In case of the 11G carburetor

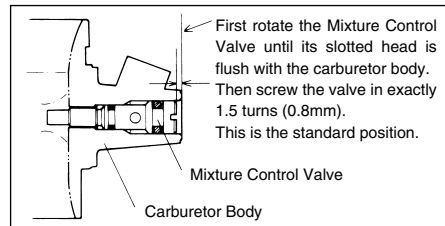

In case of the 11J carburetor

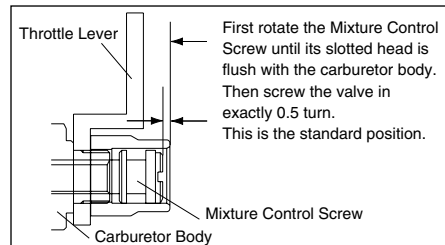

CARE AND MAINTENANCE

1. The minute particles of foreign matter, that are present in any fuel may, by accumulating and partially obstructing fuel flow, cause engine performance to become erratic and unreliable. O.S. 'Super-Filters' (large and small) are available, as optional extras, to deal with this problem. One of these filters, installed on the outlet tube inside your refueling container, will prevent the entry of foreign material into the fuel tank. It is also recommended that a good in-line filter be installed between the tank and carburetor.
2. Do not forget to clean the filters regularly to remove dirt and lint that accumulate on the filter screens. Also, clean the carburetor itself occasionally.
3. At the end of each operating session, drain out any fuel that may remain in the fuel tank. Afterwards, energize the glow-plug and try to restart the engine, to burn off any fuel that may remain inside the engine. Repeat this procedure until the engine fails to fire. Do this while the engine is still warm.

4. Then, inject some after-run oil into the engine, and rotate the engine with an electric starter for 4 to 5 seconds to distribute the oil to all the working parts.

Note:

Do not inject after-run oil into the carburetor as this may cause the O-rings inside the carburetor to deteriorate. These procedures will reduce the risks of starting difficulties or corrosion after a period of storage.

5. Finally, when cleaning the exterior of the engine, use methanol or kerosene. Do not use gasoline or any solvent that might damage the silicone fuel tubing.

Caution:

The rear crankshaft bearing of this engine uses a special plastic retainer. If the front housing needs to be heated to remove or replace the bearing, do not allow the bearing to exceed 120°C (248°F), otherwise it may be damaged and rendered unserviceable.

26

■ Installing Dust Caps

When storing the engine, install the cap on the exhaust port, carburetor, etc. to prevent dust from entering the engine.

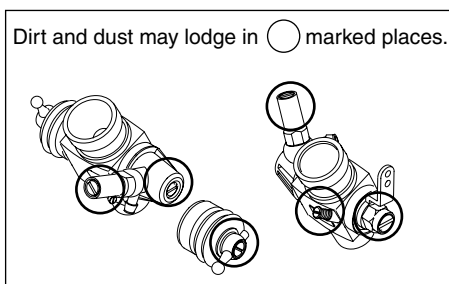

CHECKING THE ENGINE

If the engine will not develop normal performance after a long period of running it may be due to the wearing of parts. It is suggested that the worn parts be replaced when the following symptoms are detected.

- ◆ Engine sound changes and easily overheats.
- ◆ Power has dropped considerably.
- ◆ Idle is unstable and/or engine tends to stop at idle.

In most cases, ball bearings, cylinder & piston assembly, connecting rod and/or crankcase have become worn out or abnormal. Check the parts carefully and replace them if necessary.

27

TROUBLE SHOOTING	Symptom
	Engine fails to fire.
Cause	Corrective action
Fuel tank is empty. Fuel not reaching the engine.	Fill the tank with fuel and repeat Priming procedure.
Glowplug element is burnt out. Glowplug battery discharged	Replace glowplug. Recharge or replace the battery.
Clogged fuel filter Air cleaner and silencer inside is dirty.	Clean or replace fuel filter. Replace cleaner element and clean inside silencer.
Over priming	Remove glowplug and pump excess fuel.
Fuel tubing is disconnected. Fuel tubing is kinked, split or has a hole.	Connect fuel tubing securely. Check the tubing carefully and replace if necessary.
Incorrect servo linkage	Connect correctly after setting servo at neutral.
Reverse rotating direction of starter box.	Make sure it rotates counter clockwise seen from crankshaft side.
Recoil starter slips.	Inject cleaner spray into starter cord crevis on the body.

28

Symptom	
Engine fires intermittently but does not run.	
Cause	Corrective action
Insufficient fuel in the tank.	Fill the tank with fuel.
Deteriorated glowplug	Replace glowplug.
Clogged fuel filter Air cleaner and silencer inside is dirty.	Clean or replace fuel filter. Replace cleaner element and clean inside silencer.
Engine overheated	Wait until engine cools.
Incorrect clutch release	Adjust the tension of clutch spring.
Glowplug battery disconnected too soon.	Do not disconnect plug battery and wait until r.p.m. become stable.
Air bubbles in fuel	Install O rings to the tank screws to prevent bubbles.

29

Symptom	
Unstable idle	
Cause	Corrective action
Unsuitable glowplug	Use suggested glowplug in the instructions.
Unsuitable fuel	Do not use extremely high nitro or low oil content fuel.
Extremely light flywheel	Add suitable load.
Silencer is disconnected or has play	Install silencer securely.
Symptom	
Not reaching expected peak r.p.m.	
Cause	Corrective action
Insufficient warming up or running-in.	Set the needle only after warming up. Complete running-in.
Silencer or manifold is not securely connected or disconnected.	Replace seal ring. Check the connections and secure them.
Fuel tubing from tank is split or broken.	Replace the tubing.

30

Symptom	
Poor response	
Cause	Corrective action
Deteriorated glowplug	Replace glowplug.
Incorrect carburetor settings	Readjust low r.p.m. range with metering needle and mixture control valve.
Incorrect setting of transmitter Exponential function.	Check the transmitter setting.
Symptom	
Poor r.p.m. drop	
Cause	Corrective action
Throttle position open too far.	Close metering needle to adequate position to lower idle r.p.m.
Incorrect carburetor installation	Install carburetor properly.

31

18CV-R(P) w/11G ENGINE PARTS LIST

No.	Code No.	Description
1	21804010	Heatsink Head
2	21824000	Gasket Set
3	21823000	Cylinder & Piston Assembly
4	21816000	Piston Pin
5	21817000	Piston Pin Retainer (2pcs.)
6	21815000	Connecting Rod
7	21883000	Carburetor Complete (Type 11G)
8	21818000	Carburetor Retainer Assembly
9	21833000	Crankshaft Ball Bearing (Front)
10	21811000	Crankcase
11	21832000	Crankshaft Ball Bearing (Rear)
12	21812020	Crankshaft
13	21807100	Cover Plate
14	21213000	Screw Set
	71608001	Glow Plug No.8
	72412000	Super Air Cleaner 202 Assembly (w/2 filter elements)
	72412100	202 Cleaner Body
	72412200	202 Filter Elements (4pcs.)

The specifications are subject to alteration for improvement without notice.

18CV-R(P) w/11G EXPLODED VIEW

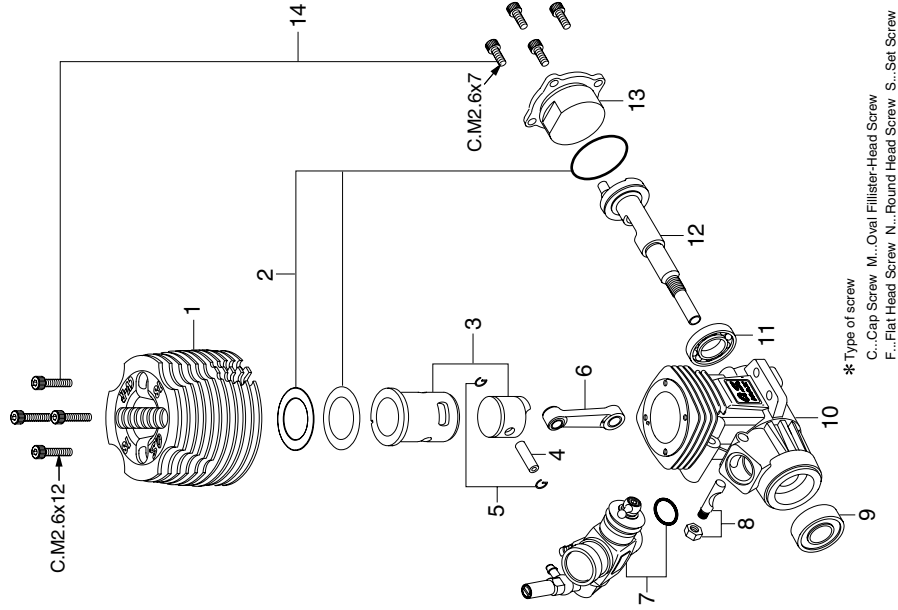

18CV-R w/11J ENGINE PARTS LIST

No.	Code No.	Description
1	21804010	Heatsink Head
2	21824000	Gasket Set
3	21823000	Cylinder & Piston Assembly
4	21816000	Piston Pin
5	21817000	Piston Pin Retainer (2pcs.)
6	21815000	Connecting Rod
7	21884000	Carburetor Complete (Type 11J)
8	21818000	Carburetor Retainer Assembly
9	20810007	Propeller Nut
10	21408000	Drive Hub
11	21833000	Crankshaft Ball Bearing (Front)
12	21811000	Crankcase
13	21832000	Crankshaft Ball Bearing (Rear)
14	21812000	Crankshaft
15	21807100	Cover Plate
16	21213000	Screw Set
	71608001	Glow Plug No.8
	72413000	Super Air Cleaner 203 Assembly (W/2 filter elements)
	72413200	203 Filter Elements (4pcs.)

The specifications are subject to alteration for improvement without notice.

18CV-R w/11J EXPLODED VIEW

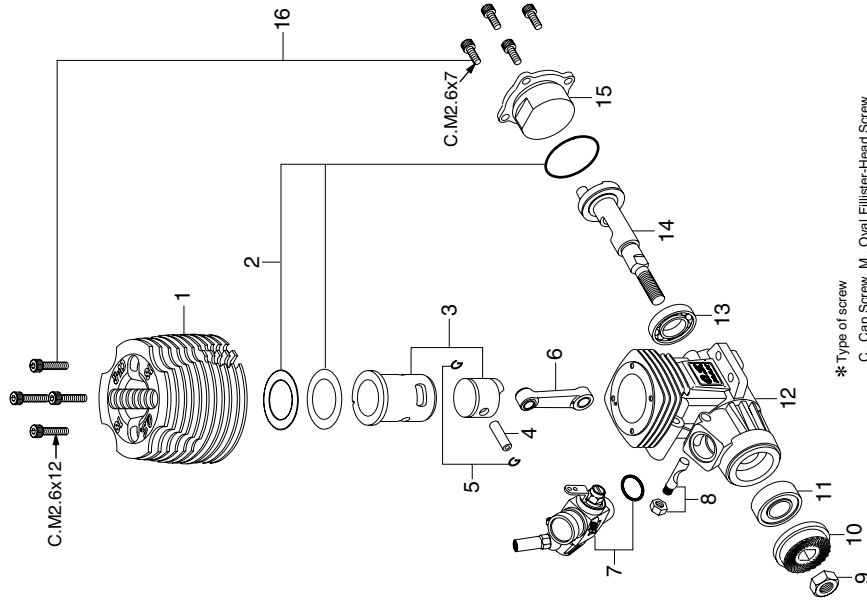

18CV-RX w/11J ENGINE PARTS LIST

No.	Code No.	Description
1	21804010	Heatsink Head
2	21824000	Gasket Set
3	21823000	Cylinder & Piston Assembly
4	21816000	Piston Pin
5	21817000	Piston Pin Retainer (2pcs.)
6	21815000	Connecting Rod
7	21884000	Carburetor Complete (Type 11J)
8	21818000	Carburetor Retainer Assembly
9	20810007	Propeller Nut
10	21408000	Drive Hub
11	21833000	Crankshaft Ball Bearing (Front)
12	21811000	Crankcase
13	21832000	Crankshaft Ball Bearing (Rear)
14	21812100	Crankshaft
15	21812200	Starting Shaft
16	21801800	Rear Adaptor
17	21313030	Screw Set
18	73003000	No.5 Recoil Starter Assembly
18-1	73003100	No.5 Recoil Starter Body
18-2	73003200	No.5 One-way Clutch
	71608001	Glow Plug No.8
	72413000	Super Air Cleaner 203 Assembly (W/2 filter elements)
	72413200	203 Filter Elements (4pcs.)
	72404000	Engine Mount Spacer

The specifications are subject to alteration for improvement without notice.

18CV-RX w/11J EXPLODED VIEW

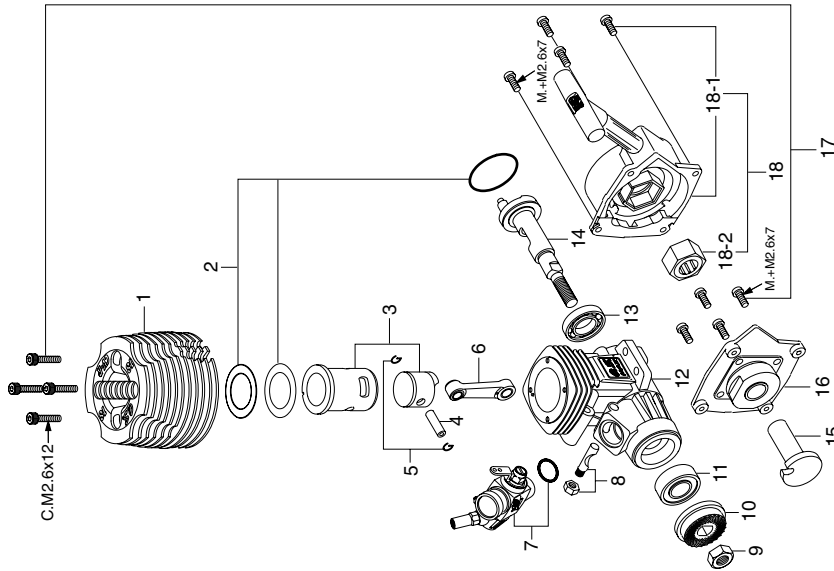

* Type of screw
 C...Cap Screw M...Oval Fillister-Head Screw
 F...Flat Head Screw N...Round Head Screw S...Set Screw

11G CARBURETOR EXPLODED VIEW

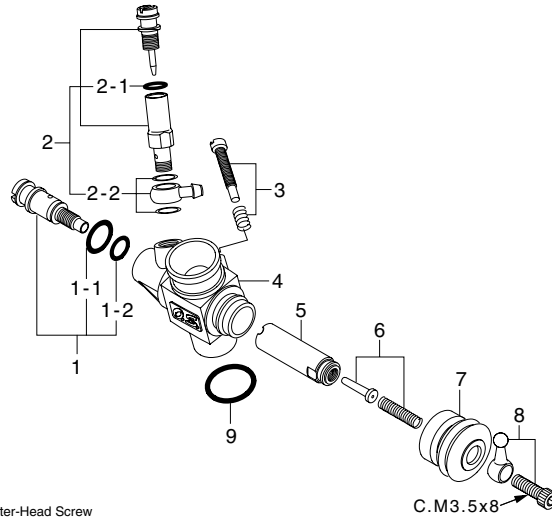

* Type of screw

C...Cap Screw M...Oval Fillister-Head Screw
F...Flat Head Screw N...Round Head Screw S...Set Screw

38

11G CARBURETOR PARTS LIST

No.	Code No.	Description
1	21285600	Mixture Control Valve Assembly
1-1	46066319	"O" Ring(L) (2pcs.)
1-2	22781800	"O" Ring(S) (2pcs.)
2	21285901	Needle Valve Assembly
2-1	27881820	"O" Ring (2pcs.)
2-2	21881950	No.14 Universal Nipple Assembly
3	23818500	Throttle Stop Screw
4	21883100	Carburetor Body
5	21483200	Slide Valve
6	21483600	Metering Needle Assembly
7	21881320	Dust Cover
8	23818420	Ball Link No.4
9	22615000	Carburetor Rubber Gasket

The specifications are subject to alteration for improvement without notice.

39

11J CARBURETOR EXPLODED VIEW

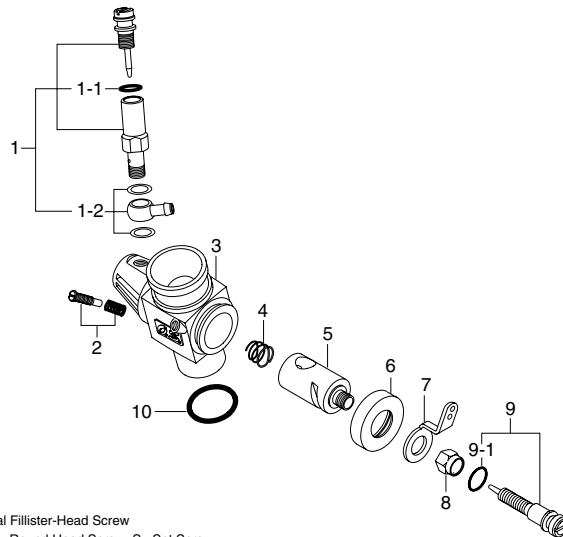

*Type of screw

C...Cap Screw M...Oval Fillister-Head Screw

F...Flat Head Screw N...Round Head Screw S...Set Screw

40

11J CARBURETOR PARTS LIST

No.	Code No.	Description
1	21285901	Needle Valve Assembly
1-1	27881820	"O" Ring (2pcs.)
1-2	21881950	No.14 Universal Nipple Assembly
2	22681310	Throttle Stop Screw
3	21884100	Carburetor Body
4	22481506	Rotor Spring
5	21884200	Carburetor Rotor
6	21283210	Dust Cover
7	22681419	Throttle Lever
8	21481420	Throttle Lever Fixing Nut
9	21484600	Mixture Control Screw
9-1	27881820	"O" Ring (2pcs.)
10	22615000	Carburetor Rubber Gasket

The specifications are subject to alteration for improvement without notice.

41

■ O.S. Glow Plug

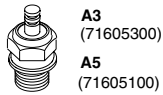

A3
(71605300)
A5
(71605100)

■ Exhaust Header Pipes

For Kyosho Super10
(72103110)



For Tamiya TGX
(72103120)



For Kyosho Spider & HPI Nitro
(72103140)



For Tamiya TG10
(72103130)



■ Tuned Silencer

T-1040 L52
(72103051)

T-1040 R52
(72103056)

T-1040 L70
(72103071)

T-1040 R70
(72103076)

■ Super Joint Tube 15
(72103310)



■ Long Socket Wrench
With Plug Grip
(71521000)

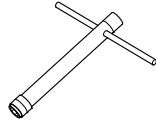

■ Dust Cap Set

Ø3 (5 pcs. set) (73300305)

For Carburetor Nipple

Ø7 (3 pcs. set) (73300712)

For Tuned Silencer

Ø16 (3 pcs. set) (73301612)

For Carburetor

■ Cap Screw Set
(10pcs. set)

M2.6x7 (79871020)

M2.6x12 (79871040)

M3.5x8 (79871060)



18CV-R(P) w/11G THREE VIEW DRAWING

SPECIFICATIONS

■ Displacement	3.0 cc (0.183 cu.in.)
■ Bore	16.0mm (0.629 in.)
■ Stroke	15.0mm (0.590 in.)
■ Practical R.P.M.	3,000-32,000 r.p.m.
■ Power output	1.35 ps / 1.37 hp / 28,000 r.p.m.
■ Weight	235g (8.30oz.)

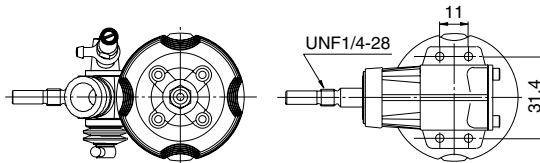

Dimensions(mm)

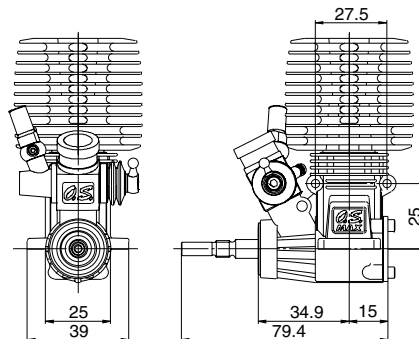

18CV-R w/11J THREE VIEW DRAWING

SPECIFICATIONS

■ Displacement	3.0 cc (0.183 cu.in.)
■ Bore	16.0mm (0.629 in.)
■ Stroke	15.0mm (0.590 in.)
■ Practical R.P.M.	3,000-32,000 r.p.m.
■ Power output	1.35 ps / 1.37 hp / 28,000 r.p.m.
■ Weight	237g (8.37oz.)

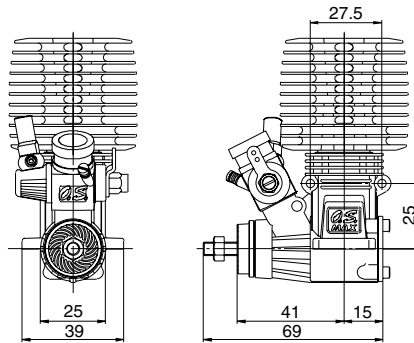
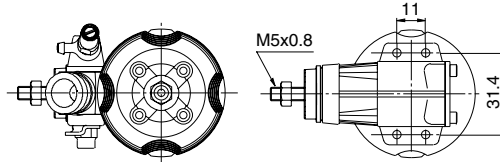

Dimensions(mm)

44

18CV-RX w/11J THREE VIEW DRAWING

SPECIFICATIONS

■ Displacement	3.0 cc (0.183 cu.in.)
■ Bore	16.0mm (0.629 in.)
■ Stroke	15.0mm (0.590 in.)
■ Practical R.P.M.	3,000-32,000 r.p.m.
■ Power output	1.35 ps / 1.37 hp / 28,000 r.p.m.
■ Weight	295g (10.41oz.)

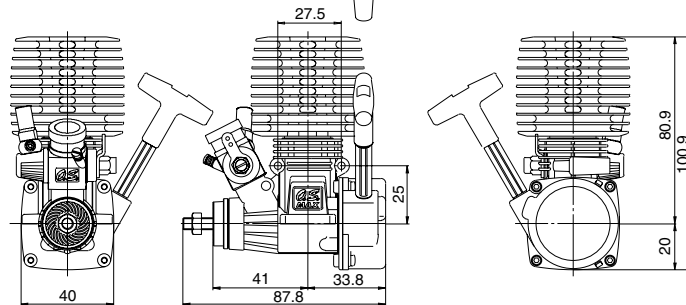
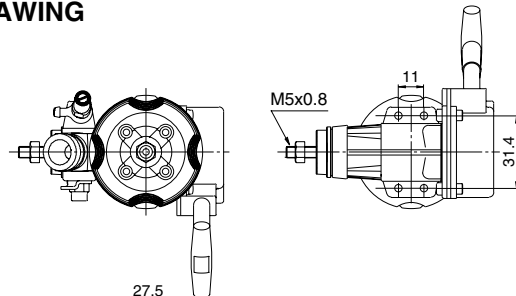

Dimensions(mm)

45

MEMO

.....

.....

.....

.....

.....

.....

.....

.....

.....

.....

.....



O.S. ENGINES MFG.CO.,LTD.

6-15 3-Chome Imagawa Higashisumiyoshi-ku
Osaka 546-0003, Japan TEL. (06) 6702-0225
FAX. (06) 6704-2722
URL : <http://www.os-engines.co.jp>