

Two stroke gasoline engine for airplanes

GT55

OWNER'S INSTRUCTION MANUAL

It is of vital importance, before attempting to operate your engine, to read the general 'SAFETY INSTRUCTIONS AND WARNINGS' section on pages 2-5 of this booklet and to strictly adhere to the advice contained therein.

- Also, please study the entire contents of this instruction manual, so as to familiarize yourself with the controls and other features of the engine.
- Keep these instructions in a safe place so that you may readily refer to them whenever necessary.
- It is suggested that any instructions supplied with the aircraft, radio control equipment, etc., are accessible for checking at the same time.

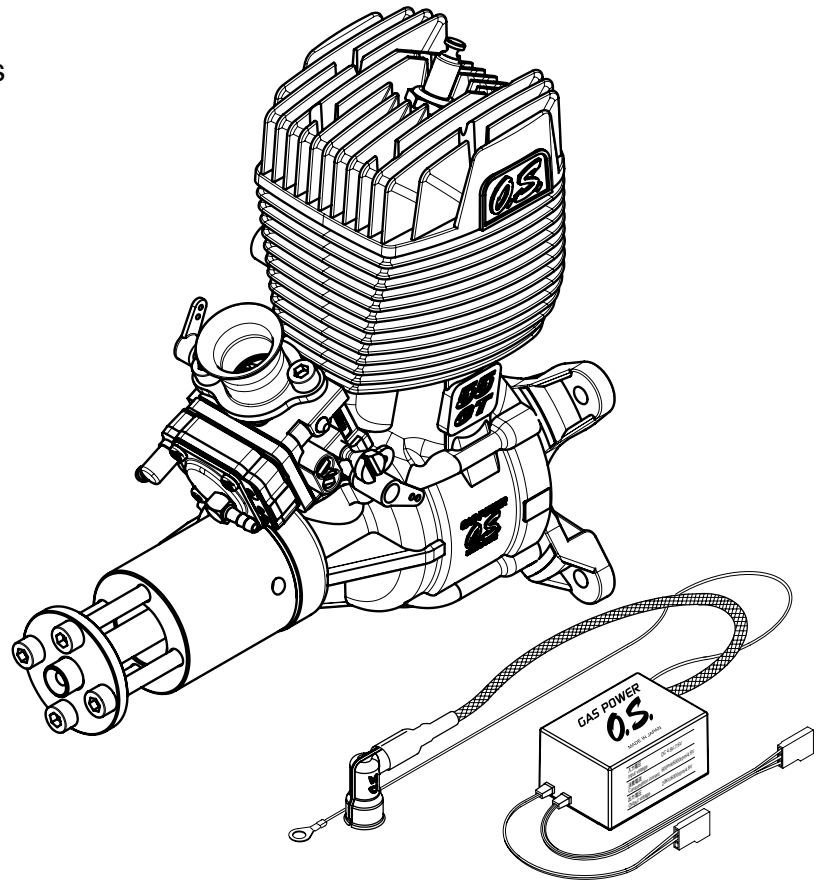

SAFETY INSTRUCTIONS AND WARNINGS ABOUT YOUR O.S. ENGINE-----	2-5	RUNNING-IN / STARTING-----	18-23
ABOUT THE ENGINE-----	6	NEEDLE ADJUSTMENTS-----	24-25
ENGINE PARTS NAME-----	7	FLIGHT & MAINTENANCE-----	26-27
SILENCER / INSTALLATION-----	8	ENGINE EXPLODED VIEW-----	28
FUEL TANK & LINES-----	9	ENGINE PARTS LIST-----	29
CARBURETOR WLA-2 PARTS NAME-----	10	CARBURETOR EXPLODED VIEW-----	30
CARBURETOR LINKAGE-----	11-12	CARBURETOR PARTS LIST-----	31
IGNITION MODULE-----	13-14	O.S. GENUINE PARTS & ACCESSORIES-----	32-33
PROPELLER-----	15-16	ENGINE THREE VIEW DRAWINGS-----	34
MIXING OF OIL-----	17		

SAFETY INSTRUCTIONS AND WARNINGS ABOUT YOUR O.S. ENGINE

Remember that your engine is not a "toy", but a highly efficient internal-combustion machine whose power is capable of harming you, or others, if it is misused or abused. As owner, you, alone, are responsible for the safe operation of your engine, so act with discretion and care at all times.

If at some future date, your O.S. engine is acquired by another person, we would respectfully request that these instructions are also passed on to its new owner.

■ The advice which follows is grouped under two headings according to the degree of damage or danger which might arise through misuse or neglect.

WARNINGS

These cover events which might involve serious (in extreme circumstances, even fatal) injury.

NOTES

These cover the many other possibilities, generally less obvious sources of danger, but which, under certain circumstances, may also cause damage or injury.

WARNINGS

- Never touch, or allow any object to come into contact with the rotating propeller and do not crouch over the engine when it is running.



- Gasoline is poisonous. Do not allow it come into contact with the eyes or mouth. Always store it in a clearly marked container in a cool and dark place and out of the reach of children. There is a possibility that it may damage your health.



- Gasoline is highly flammable. Keep it away from an open flame, excessive heat, sources of sparks, or anything else which might cause it to ignite. Do not smoke or allow anyone else to smoke near to it.



- Carry out the mixing of the gasoline and oil outdoors or in a well ventilated place away from any source of fire to prevent the possibility of a fire.



- Refill the fuel tank only after the engine is well cooled down, or there is a danger of fire.



2

WARNINGS

- Observe the laws and regulations in each country and district concerning the usage, transportation and storage of gasoline. Ask details at fire station in each district.

- Model engines generates considerable heat. Do not touch any part of your engine until it has cooled. Contact with the muffler (silencer), cylinder head or exhaust header pipe, in particular, may results in a serious burn.



- Never operate your engine in an enclosed space. Model engines, like automobile engines, exhaust deadly carbon-monoxide. Run your engine only in an open area.

- Do not operate the engine nor model alone, or there is a possibility of injury.

NOTES

- Any propeller requires utmost attention to handle. Be sure to follow the instruction manual supplied with a propeller.

- This engine was designed for model aircraft. Do not attempt to use it for any other purpose.

- Start the engine only after installing it in the model. Do not start the engine before installing it in the model, or there is a possibility of injury.

- Be sure to use an effective silencer (muffler). Frequent exposure to an open exhaust may eventually impair your hearing. Such noise is also likely to cause annoyance to others over a wide area.

- Mount the engine in your model securely, following the manufacturers' recommendations.

- For their safety, keep all onlookers (especially small children) well back (at least 10 meters) when preparing your model for flight.

3



NOTES

- When checking a spark plug with the power source on, do not hold the plug, plug cap, high tension cord nor grounding wire, or you will get a shock.
- Install a top-quality propeller of the diameter and pitch specified for the engine and aircraft.
- Do not use a nylon propeller. It has the possibility of flying apart due to strong centrifugal force caused by high rpm.
- Discard any propeller which has become split, cracked, nicked or otherwise rendered unsafe. Never attempt to repair such a propeller: destroy it. Do not modify a propeller in any way.
- Install the propeller on the shaft so that the curved face of the blades faces forward – i.e. in the direction of flight. Firmly tighten the propeller washer and propeller installing screws using the correct size wrench. Always check the tightness of propeller installing screws and retighten them, if necessary, before starting the engine. Also, check the tightness of all the screws and nuts before restarting the engine.
- Always check the throttle linkage. If it is disconnected, throttle action becomes uncontrollable, which may result in a serious accident.
- Take care that loose clothing (ties, shirt sleeves, scarves, etc.) do not come into contact with the propeller. Do not carry loose objects (such as pencils, screwdrivers, etc.) in a shirt pocket from where they could fall through the propeller arc.
- Use an electric starter for this engine. The wearing of safety glasses is also strongly recommended. If you try hand starting, be sure to use a chicken stick or heavy glove. Never attempt to start the engine with a bare hand.
- Be sure to carry out adjustments of the high speed needle and slow speed needle after stopping the engine.
- Do not start your engine in an area containing loose gravel or sand. The propeller may throw such material in your face and eyes and cause injury.



NOTES

- If you have to carry the model to the take-off point with the engine running, be especially cautious. Keep the propeller pointed away from you and walk well clear of spectators.
- Switch off the ignition module to stop the engine or fully close the throttle valve via the transmitter to shut off the fuel supply. Otherwise there is a possibility of injury.
- Immediately after the engine is stopped, the engine may start with a crank even when the igniter switch is off. Do not crank the engine, or there is a possibility of injury.
- Be sure to install an externally operable switch for the ignition system battery to stop the engine if it is started unintentionally with the radio transmitter turned off or there is the possibility of injury.
- Connect the throttle linkage so that the engine can be stopped via radio operation.

- This engine is designed for experienced fliers. Beginners and newcomers should not use this engine.
- The engine unit, carburetor and igniter are specially designed.
- It offers broad power characteristics suitable for sport flight as well as acro flight.
- The large and dense cooling fins ensure sufficient cooling against overheating.
- The specially designed ignition module "IG-01" is equipped with a micro computer and designed not to operate at low rpm and run intermittently when the battery voltage drops. It provide high voltage for sure firing through the operating range while utilizing a low current draw.

STANDARD ACCESSORIES

- Spark Plug CM-6



- Exhaust Gasket GT55

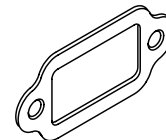

- Ignition module Assembly (IG-01)

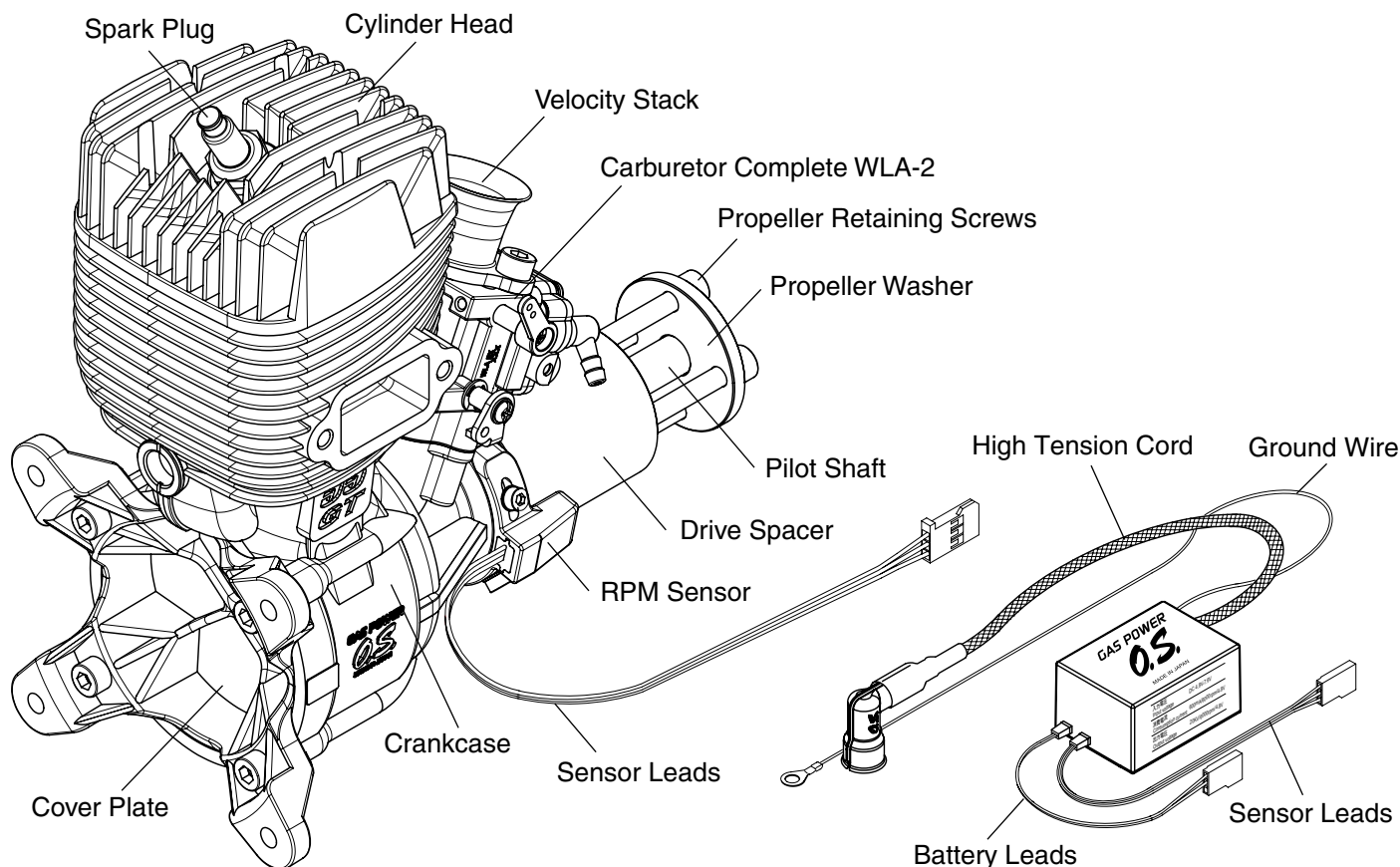
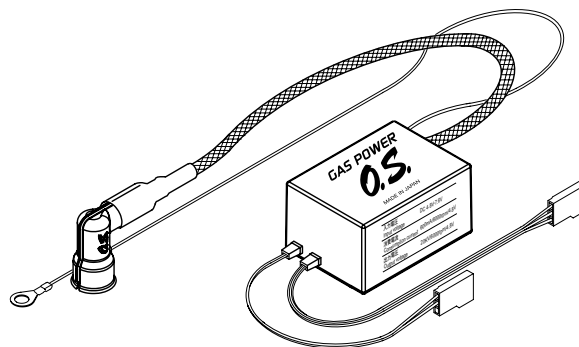



Be sure to use an effective silencer (muffler). Frequent exposure to an open exhaust may eventually impair your hearing. Such noise is also likely to cause annoyance to others over a wide area.

- The GT55 does not come with a silencer. Select an effective silencer from commercially available ones. (Mounting bolt pattern is the same as most other makes of the similar engine size.)



Mount the engine in your model securely, following the manufacturers' recommendations.

- Use a strong enough material for the mounting face of the model, such as birch ply firewall of more than 8mm thick.
- Make sure the mounting face of the model is flat. If it is uneven, work on it to be flat. (When shims are added to change the thrust angle, work on it to be flat.)
- Engine mounting face has been high-precision machined flat. Make sure mounting face of the model is also flat.

- Use 5mm steel hex socket head bolts to install the engine. (Do not use brass, soft steel nor aluminum screws, because they are not strong enough.) Also, use the Nord Lock Washers (optional extra) and other anti-loosening washers or apply locking agent.
- Be sure that there is sufficient air intake and outlet area on the model for engine cooling to avoid overheating. (Pay careful attention to the cooling since a gasoline engine generates more heat than a glow engine.)
- Secure at least a 30mm dia. area around the air intake of the velocity stack so that the air intake will not be restricted. (Cut out the cowling big enough if necessary.)

- Use a tank designed for gasoline. (Tanks designed for glow fuel use a rubber cap which is deteriorated by gasoline.)
- A 600cc tank will provide 13~14 minutes flight.
- Install a commercially available gasoline fuel filter between fuel tank and carburetor. (Clean the filter from time to time.)
- For plumbing use TYGON® F-4040 (Yellow color) or strong nitrile rubber of more than 3mm ID and 6mm OD. Replace tubing periodically as it becomes hardened. (Replace tubing inside the fuel tank every six months.)
- Use fuel line keepers at the end of the tubing to prevent it from coming off.
- This engine does not require a pressurized fuel system but be sure to provide an air vent.
- Be sure to install an in-line fuel filter between the tank and carburetor to prevent foreign matter in the tank from entering the carburetor. Clean the filter periodically.

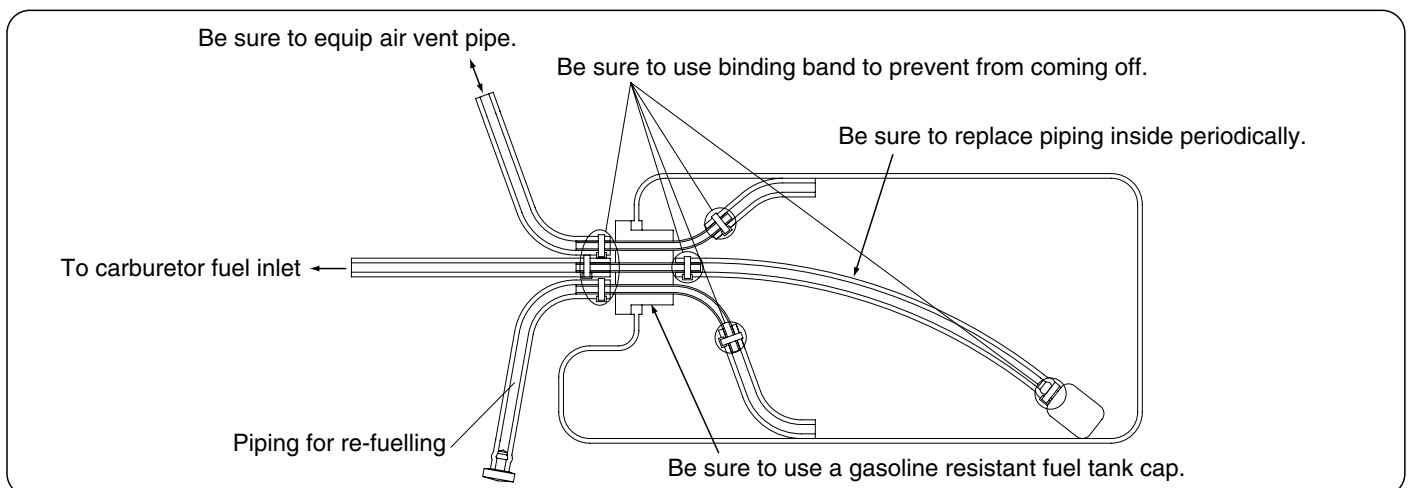

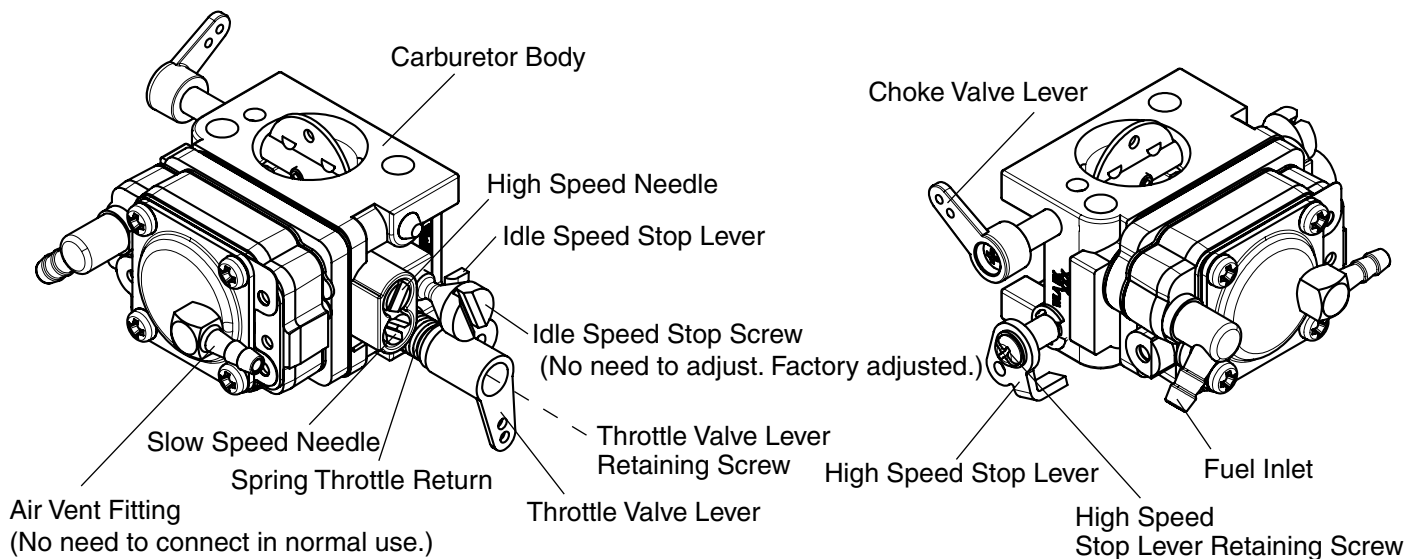

Connect the throttle linkage so that the engine can be stopped via radio operation.

- Connect the throttle linkage so that the engine can be stopped by radio operation in case of unexpected starting, or there is a possibility of injury.
- Throttle lever can be installed either on right or left. Here is a changing procedure.

1. Remove the throttle lever retaining screw. (Pay attention not to lose this screw because it is special size.) Also, be careful not to remove the idle stop screw and return spring. If they are removed accidentally, assemble them being aware of the small notch.
2. Then, remove the opposite side high speed stop retaining screw. (Pay attention not to lose this screw because it is special size.) At this time, be careful not to remove the high speed stop lever.
3. Then, install the throttle lever with the throttle lever retaining screw.
4. Then, install the idle speed stop lever with the high speed stop lever retaining screw.

NOTE

When loosening and tightening each retaining screw, do so with the throttle valve at mid position.
 (If the throttle valve lever retaining screw is loosened or tightened with the throttle valve fully opened or closed, excessive force will be applied, which will result in breaking the lever.)

- Before connecting the throttle linkage, make sure that the throttle valve lever does not interfere with the bulkhead or mount of the model when it is fully closed and opened.
- Connect the throttle linkage so that clearance gap between the idle stop and idle speed stop lever distance is 1~1.5mm (refer to the sketch shown below) when the throttle stick on the transmitter is fully pulled down and the throttle valve is fully closed as well as the trim lever on the transmitter.

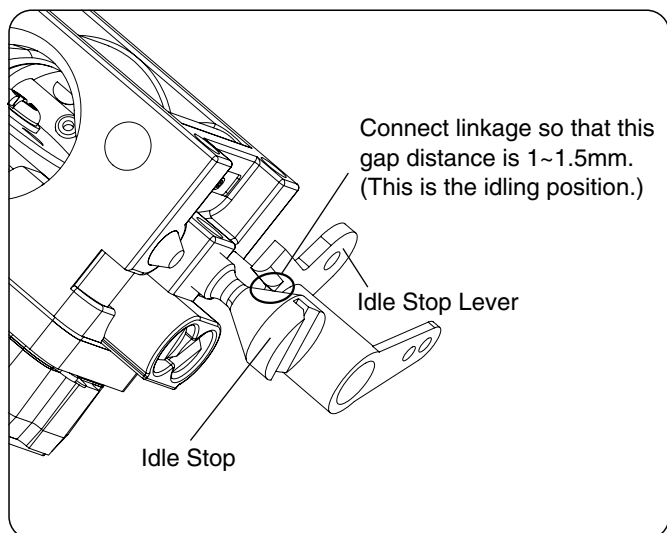

- Connect the linkage so that the throttle valve is fully opened when the throttle stick on the transmitter is fully advanced. (Adjust the movement so that the pushrod does not bind when the throttle valve is fully closed and fully opened.)
- Connect the linkage so that the servo arm and pushrod, and throttle valve lever make a right angle when the throttle stick on the transmitter is placed at mid position to avoid differential action.
- When changing the throttle valve lever and choke valve lever direction, loosen and tighten each retaining screw placing each lever at mid position. (If the throttle valve lever retaining screw is loosened or tightened with the throttle valve fully opened or closed, excessive force will be applied, which will result in breaking the lever.)
- There is no need to connect to the air vent fitting in normal use. However, if the engine does not run steadily due to pressure change caused by airflow in the cowl, connect tubing to the inside of the fuselage.

12



When checking the spark plug with the power source on, do not hold the plug, plug cap, high tension cord nor grounding wire, or you will get a shock.



Be sure to equip an externally-operable switch for the ignition system battery to stop the engine if started unexpectedly without switching on the radio system, or there is a possibility of injury.

■ Major specifications

- Consumption current is 600mA/6,000rpm.
User a power source of more than 1000mA/h capacity.
- For safety, with this ignition module the engine runs intermittently over 5,000rpm when the power source voltage drops below 3.8V.
With this intermittent running rpm do not increase the rpm above mid speed, and land the model immediately.
- The ignition module is set not to operate below 100rpm for safety.
- The voltage of power source is 4.8~7.4V (rated).
(Ni-Cd, Ni-H 4~6 cells, Li-Po, Li-Fe 2 cells)

■ Installation

- Install the ignition module taking sufficient anti-vibration measures.
- Install the ignition module at least 100mm away from the engine and in a place where there is airflow so that engine exhaust heat and radiation heat do not affect its operation.
- Do not share the power source with receiver and use a separate power source.
- Equip an ON/OFF switch between the ignition module and its power source and install it in a place where can be operated from outside the model.
- Install the ignition module and its power source as far as possible away from the servos and receiver power source.
- Connect the ignition module grounding wire to the engine.
- Make sure the jackets of high tension cord and grounding wire do not touch the engine and cowl to avoid accidental short circuit.
- Install the plug cap on the plug securely.

■ **Precautions**

- Do not disassemble the ignition module and plug cap. (The ignition module is irreparable. Replace it when necessary.)
- Be careful not to mount the ignition module so that it can be hit by water, gasoline or exhaust.
- Avoid using the engine when the external temperature is over 40°C.
- Do not move the rpm sensor as it is placed at it's optimum position, otherwise the engine will not run properly.
- Do not pull on the high tension cord to remove the plug cap, or the wire will break. Be sure to hold the plug cap to remove it.
- Do not connect nor disconnect the rpm sensor with the ignition module on, or there is a possibility it will fire and the engine start.
- Check the ignition module for spark when installing the plug cap on the plug and be careful about getting a shock. Make sure there is no flammable material or gasoline vapors near by that could ignite.
- Do not turn the propeller with the ignition module on, or there is a possibility the engine will start.

PROPELLER



Never touch, or allow any object to come into contact with the rotating propeller and do not crouch over the engine when it is running.



Install a top-quality propeller of the diameter and pitch specified for the engine and aircraft.



Do not use a nylon propeller. It has the possibility of flying apart due to strong centrifugal force caused by high rpm.



Discard any propeller which has become split, cracked, nicked or otherwise rendered unsafe. Never attempt to repair such a propeller: destroy it. Do not modify a propeller in any way.

- Use a wooden or a carbon fiber propeller. Do not use a nylon propeller.
- The choice of propeller depends on the design and weight of the aircraft and on the type of flying in which you will be engaged. Determine the best size and type after practical experimentation. As a starting point, refer to the props listed in the table shown below. Slightly larger, or even slightly smaller props than those shown in the table may be used, but remember that propeller noise will increase if blade tip velocity is raised due to high rpm or if a larger diameter/lower pitch prop is used. Be well aware propeller rotating arc is very large due to a large propeller used with this engine. Carry out the needle adjustments only after stopping the engine. Do not allow your face or hands to come close to the rotating prop.

Type	Size (DxP)
Running-in	22x8
Sport/Acro/Scale	22x10 23x8 23x10 24x8 24x10

Warning:
Make sure that the propeller is well balanced. An unbalanced propeller and/or spinner can cause serious vibration which may weaken parts of the airframe or affect the safety of the radio-control system.
Do not use any propeller which has become split, cracked or nicked even very slightly, or received strong impact even if no apparent damage is visible.

■ **INSTALLATION OF PROPELLER**



Install the propeller on the shaft so that the curved face of the blades faces forward – i.e. in the direction of flight. Firmly tighten the propeller washer and propeller retaining screws using the correct size wrench. Always check the tightness of propeller retaining screws and retighten them, if necessary, before restarting the engine.

- If the supplied retaining screws are too long due to a thinner prop hub or too short due to a thicker prop hub (cannot be screwed into the drive hub by more than 10mm), Use suitable length strong steel hex socket head cap screws.
- Install the propeller before the first flight of the day and remove it after the day's flight.
- Make a habit of always checking the tightness of propeller retaining screws making sure they are free of, damage or rust before starting the engine. Replace the propeller periodically (every 50 flights) even if it looks as if nothing is wrong.



Gasoline is poisonous. Do not allow it to come into contact with the eyes or mouth. Always store it in a clearly marked container in a cool and dark place out of the reach of children. There is a possibility that it may damage your health.



Gasoline is highly flammable. Keep it away from an open flame, excessive heat, sources of sparks, or anything else which might ignite it. Do not smoke or allow anyone else to smoke near to it.



Carry out mixing of gasoline and oil in a well-ventilated and free of fire outdoor, place or there is a possibility of fire.



Refill the models fuel tank only after the engine has well cooled down, or there is a danger of fire.



Observe the laws and regulations in each country and district concerning the usage, transportation and storage of gasoline. Ask details at fire station in each district.

- Use regular gasoline. (No need to use high octane gasoline.)
- Alcohol based glow fuel cannot be used in this engine. Not only will the engine not work properly but the internal carburetor plastic parts will be damaged.
- Use high quality commercially available 2 stroke engine oil.
- Follow the oil manufacturer's recommendations concerning the mixture ratio of gasoline and oil. If there is no recommendation, mix with a 30:1 ratio. We have checked and approved the following oil mixture ratio.
KLOTZ ModelLube®(50:1), COSMO Cosmo Terra 2 cycle (50:1), RED LINE Two-Stroke Racing Oil (40:1). (This does not mean we guarantee the quality of these oils.)
Follow the instructions in the running-in section concerning the mixture for running-in.
- With a gasoline engine, passages in the carburetor are narrower than that of a glow engine, and therefore very sensitive against foreign matter such as dust. It is suggested to use optional accessory Super Filter L (Code No. 72403050) when filling a tank in the model from a container used for transportation or storing.



Always check the throttle linkage. If it is disconnected, the engine becomes uncontrollable, which may result in a serious accident.



Take care that loose clothing (ties, shirt sleeves, scarves, etc.) do not come into contact with the propeller. Do not carry loose objects (such as pencils, screwdrivers, etc.) in a shirt pocket from where they could fall through the propeller arc.



Use an electric starter for this engine. The wearing of safety glasses is also strongly recommended.

If you try hand starting, be sure to use a chicken stick or heavy glove. Never attempt to start the engine with bare hand.



Be sure to carry out adjustments of the high speed needle and slow speed needle after stopping the engine.



Do not start your engine in an area containing loose gravel or sand. The propeller may throw such material in your face and eyes and cause injury.

- Use a fuel with increased oil content and set the needle a little on the rich side. Too rich a needle setting may cause misfiring or erratic running due to fouling of the plug.
- Use a 25:1 fuel/oil mixture if the particular brand of oil states 30:1. If the oil states 50:1, use a 30:1 mix. Set the high speed needle 100~200 below maximum rpm. The low speed needle need not be richened.
- No need to carry out running-in on a bench nor with the model fixed. Just fly the model with the above mentioned fuel and needle setting.
- A total of 10 flights (5~6 liters fuel) are required. Avoid prolonged full throttle running at initial stage, and gradually extend the full throttle running time.

WARNING:

When ground running the engine, avoid dusty or sandy locations. If dust or grit is drawn into the engine, this can have a ruinous effect, drastically shortening engine life in a matter of minutes.

Since the carburetor points downward when the engine is installed inverted, it becomes more difficult for the fuel to reach the carburetor on priming (choking). Therefore a heavier priming will be required.

■ Initial needle position

When starting the engine for the first time, set both the high speed needle and the slow speed needle two turns open from the fully closed position.

With this position both high and slow speed mixtures will be rich.

If the settings are upset, come back to this setting and adjust them according to procedure in the needle setting section.

■ Starting by an electric starter

● First starting of the day

1. Make sure the ignition switch is off.
2. Close the choke valve fully.
3. Set the throttle stick on the transmitter at bottom or 1/8 (2~3 clicks) advanced from the bottom.
4. Flip the propeller with a Chicken stick or gloved hand until the fuel runs out of the carburetor. (In case of upright and side installation, flip 7~8 more times after the fuel reaches the carburetor.) Do not use an electric starter, or the engine will be over-primed.
5. Open the choke valve fully.
6. Make sure the throttle stick is at the bottom or 1/8 (2~3) advanced from the bottom.
7. Turn on the ignition switch.
8. Tell the helper and onlookers that you will start the engine now and have the helper hold the model securely.
9. Apply the electric starter.

● Second and later starting of the day

1. Set the throttle stick on the transmitter at bottom or 1/8 (2~3 clicks) advanced from the bottom.
2. Make sure the choke valve is fully opened.
3. Turn on the ignition switch.
4. Tell the helper and onlookers that you will start the engine now and have the helper hold the model securely.
5. Apply the electric starter.

**■ Starting with a Chicken stick or gloved hand No.1
(Two different procedures are explained.)****(It is suggested to use an electric starter.)****● First starting of the day**

1. Make sure the ignition switch is off.
2. Close the choke valve fully.
3. Fully advance the throttle stick on the transmitter.

4. Flip the propeller until the fuel runs out of the carburetor, then flip 3~4 times more (6~7 times in winter). (In case of upright and side installation, flip 7~8 more time after the fuel reaches the carburetor.)
5. Open the choke valve fully. With the throttle stick fully open, flip 6~7 times to draw the fuel mixture into the cylinder.
6. Set the throttle stick on the transmitter at bottom or 1/8 (2~3 clicks) advanced from the bottom.
7. Turn on the ignition switch.
8. Tell the helper and onlookers that you will start the engine now and have the helper hold the model securely.
9. Usually the engine starts with 1~3 flips. If you have only short runs or the engine does not start with more than 10 flips, most probably priming is not sufficient. Repeat the procedure from the beginning.

Note

If the engine does not start after more than 5 times repeat the procedure, over-priming is suspected. Check whether the plug is wet or not. If the plug is wet, replace it or wait until it is dried. Then, flip the propeller swiftly (15~20 times) with the plug removed to eject the fuel in the cylinder. Then, install the plug and repeat the starting procedure.

● Second and later starting of the day**Starting with a Chicken stick or gloved hand while the engine is warm**

1. Set the throttle stick on the transmitter at bottom or 1/8 (2~3 clicks) advanced from the bottom.
2. Make sure the choke valve is fully open.
3. Turn on the ignition switch.
4. Tell the helper and onlookers that you will start the engine now and have the helper to hold the model securely.
5. Flip the propeller with a Chicken stick or gloved hand to start the engine.

Starting with a Chicken stick or gloved hand when the engine is cold

1. Make sure the ignition switch is off.
2. Close the choke valve fully.
3. Fully advance the throttle stick on the transmitter.
4. Flip a propeller 2~3 times (3~4 times in winter). (In case of upright and side installation, flip 3~4 times.)
5. Open the choke valve fully. Flip the propeller 6~7 times to draw the mixture into the cylinder with the throttle stick fully advanced.
6. Set the throttle stick at bottom or 1/8 (2~3 clicks) advanced from the bottom.
7. Turn on the ignition switch.
8. Tell the helper and onlookers that you will start the engine now and have the helper to hold the model securely.
9. Flip the propeller with a Chicken stick or gloved hand to start the engine.

■ Starting with a Chicken stick or gloved hand No.2

(It is suggested to use an electric starter.)

● First starting of the day

1. Make sure the ignition switch is off.
2. Close the choke valve fully.
3. Set the throttle stick at bottom or 1/8 (2~3 clicks) advanced from the bottom.
4. Flip the propeller until the fuel runs out of the carburetor, then flip 3~4 times more (6~7 times in winter).
(In case of upright and side installation, flip 7~8 more time after the fuel reached the carburetor.)
5. Open the choke valve fully.
6. Turn on the ignition switch.
7. Tell the helper and onlookers that you will start the engine now and have the helper hold the model securely.
8. Flip the propeller with a Chicken stick or gloved hand to start the engine. Usually the engine will start with 5~6 flips. If you have only short runs or the engine does not start with more than 15 flips, most probably the priming is not sufficient. Repeat the procedure again.

Note

If the engine does not start after more than 5 times repeat the procedure, over-priming is suspected.

Check whether the plug is wet or not. If the plug is wet, replace it or wait until it is dried.

Then, flip the propeller swiftly (15~20 times) with the plug removed to eject the fuel in the cylinder.

Then, install the plug and repeat the starting procedure.

● Second and later starting of the day**Starting with a Chicken stick or gloved hand while the engine is warm**

1. Set the throttle stick at bottom or 1/8 (2~3 clicks) advanced from the bottom.
2. Make sure the choke valve is fully open.
3. Turn on the ignition switch.
4. Tell the helper and onlookers that you will start the engine now and have the helper hold the model securely.
5. Flip the propeller to start the engine.

Starting with a Chicken stick or gloved hand when the engine is cold

1. Make sure the ignition switch is off.
2. Close the choke valve fully.
3. Set the throttle stick at bottom or 1/8 (2~3 clicks) advanced from the bottom.
4. Flip the propeller 2~3 times (3~4 times in winter).
5. Open the choke valve fully.
6. Turn on the ignition switch.
7. Tell the helper and onlookers that you will start the engine now and have the helper hold the model securely.
8. Flip the propeller to start the engine.

The slow speed needle is effective through the high speed range, while the high speed needle is not effective in the low speed range. Both needles are effective in the mid speed range, while the slow speed needle is the most effective. (Refer to the diagram below.)

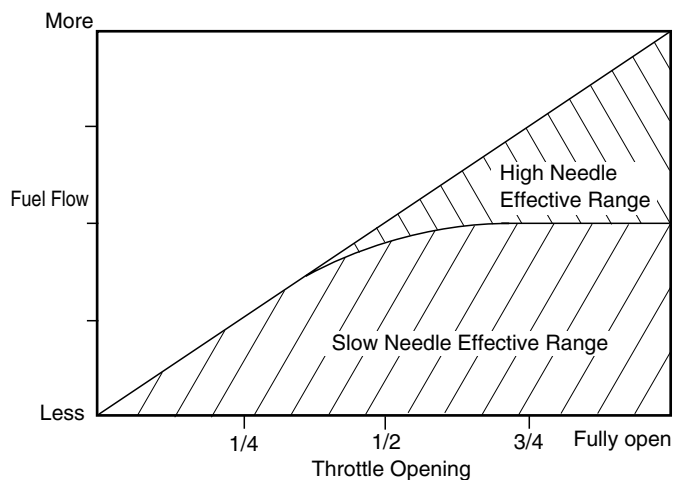

Carry out the needle settings as follows.

■ Adjustment on the ground

1. Set both needles at two turns open from the fully closed position.

2. Start the engine. Open the throttle valve slowly until fully open and run the engine for 10 seconds to warm the engine.
3. Set the throttle stick 3 clicks advanced from the bottom and measure rpm with a tachometer and write it down.
4. Close the slow speed needle approx. 30 degrees and measure rpm with a tachometer and write it down. (Be sure to adjust the slow needle only after stopping the engine.)
5. Repeat step 4. to locate the slow speed needle position where maximum rpm is achieved. Open it approx. 60 degrees from this position. This is the basic slow needle position.
6. Open the throttle valve fully and measure rpm with a tachometer and write it down.
7. Close the high needle approx. 30 degrees and measure rpm and write it down. (Be sure to adjust the high needle only after stopping the engine.)
8. Repeat step 7. to locate the high needle position where maximum rpm is achieved. Open it approx. 30 degrees from this position. This is the basic high needle position.
9. Set the throttle trim on the transmitter so that the idle rpm is approx. 2,000 (approx. 1,600rpm when idle down function is used).

24

10. Warm the engine for 10 seconds with the throttle fully open, then idle the engine for 5 seconds, then quickly open the throttle fully. Make sure the engine does not respond sluggishly to increase rpm nor hesitates before picking up speed or even ceases firing.

11. If the engine responds sluggishly to increase rpm, the mixture is too rich due to the slow speed needle being open too far. Close the slow speed needle approx. 15 degrees. Repeat this procedure until the engine accelerates smoothly. (Be sure to adjust the slow speed needle only after stopping the engine.)

12. If the engine hesitates before picking up speed or ceases firing, the mixture is too lean due to the slow speed needle being open too far. Open the needle approx. 15 degrees. Repeat this procedure until the engine accelerates smoothly. (Be sure to adjust the slow speed needle only after stopping the engine.)

■ Adjustment with flight

13. If the rpm drops or the exhaust sound weakens when vertically climbing from level flight with full throttle, the mixture is too lean. Land the model and open the high speed needle approx. 15 degrees. Repeat this procedure until the engine sound is smooth.

14. If, on the other hand, exhaust sound is irregular when vertically climbing from level flight, the mixture is too rich. Land the model and close the high speed needle approx. 15 degrees. Repeat this procedure until the sound in level flight is steady.

15. If the power drops gradually or exhaust sound weakens (overheating symptom), when performing torque roll and hovering, the mixture is too lean. Land the model and open the slow speed needle approx. 15 degrees. Repeat this procedure until power remains steady.

16. If the above symptom is not detected with prolonged torque roll and hovering but sluggish to increased rpm when the throttle is fully opened abruptly, the mixture is too rich. Land the model and close the slow speed needle approx. 15 degrees until sluggish rpm increase disappears.

Note

Generally, a gasoline engine is sensitive to a lean mixture compared with a glow engine, and will stop without warning hesitation and stops with overheating.

It is recommended that the engine be run with a slightly richer mixture.

■ Checking prior to flight

- When the engine is started, make sure the radio control system works normally (distance test).
- Engine does not run erratic with full throttle.
- Idling is stable.
- Responds positively to the throttle operation.
- Warm-up is finished.

Warm-up is required as with full size aircraft and car engines. Take off the model after warming the engine for approx. 10 seconds with full throttle.

■ Precautions in flight

- A slight engine rpm increase and decrease delay is normal. Abrupt throttle operation will cause engine to quit. Move throttle smoothly.
- Due to the construction of the carburetor, 70~80% of maximum power develops with half throttle. If you feel uneasy with this, adjust with transmitter function (exponential and throttle curve, etc.) or differential of throttle linkage.
- Cooling is more vitally important to a gasoline engine than to a glow engine. If overheating symptoms (loss of power at full throttle or exhaust note at mid speed changes from cloudy one to clear one) are observed during flight, immediately stop flying and carry out the following countermeasures.

- 1) Enlarge the air intake cutout on the cowling.
- 2) Enlarge the air outlet cutout on the cowling. (It is vitally important.)
- 3) Partly cover the air intake cutout on the cowling where air does not hit direct the engine.
- 4) Install an air guiding plate on the fuselage and cowling so that cooling air may be guided to the cylinder portion of the engine and muffler.

- When the interval between the flights is short and the engine is still hot, it may be possible overheating symptoms are observed by circulating the head from the former flight through the engine even if the overheating symptoms were not observed during the former flight. In this case, leave it until the engine is fully cooled down (in hot weather, it may take more than one hour.) or run the engine for 4 to 5 minutes at idling.

■ Maintenance after the day's flights

Please pay attention to the matter described below to ensure that your engine serves you well in regard to performance, reliability and long life.

- Check the tightening of each screw, especially engine installing screws and silencer installing screws each time. Also, for the first several flights, tighten the screws after each flight.

- As previously mentioned, it is vitally important to avoid operating the engine in conditions where dust, distributed by the propeller, may be deposited on the engine and enter its working parts.
- Remember to keep your fuel container closed to prevent foreign matter from contaminating the fuel.
- Install a fuel filter to prevent foreign matter in the fuel container from entering the fuel tank. O.S. Super Filter (L) is available as an optional extra.
- Install an in-line fuel filter between the tank and carburetor to prevent foreign matter in the tank from entering the carburetor.
- Clean these filters periodically.
- If these precautions are neglected, restrictions of fuel flow may cause the engine to cut out, or the fuel/air mixture to become too lean causing the engine to overheat.
- With a gasoline engine rust hardly occurs. Check the exterior to make sure there is nothing wrong and wipe off any oil res.
- Fill the carburetor with fuel at the conclusion of a day's flying. (Pay careful attention to fire and ignition source when carrying and storing the model.)
If the engine is stored without filling the carburetor, with fuel the inside parts will dry out and not work properly at the next running. If the engine quits out of fuel, refill the carburetor with fuel.
- When the engine is not to be used for a long period (more than a year), remove the engine from the model, clean the outside then remove the carburetor, and plug all tubing. Clean inside the engine by rotating the crankshaft with the engine immersed in container filled with gasoline.
- Also use gasoline to clean the outside of the carburetor. Do not use kerosene, or the inside parts will be damaged. Clean the outside only because the inside parts are sensitive to foreign matter.
- After cleaning the engine, dry it well then inject a small quantity of oil used to mix fuel and rotate the crankshaft several times to distribute the oil well inside the engine. Finally reassemble the engine and store it in a dry place after inserting it in a heavy vinyl bag.

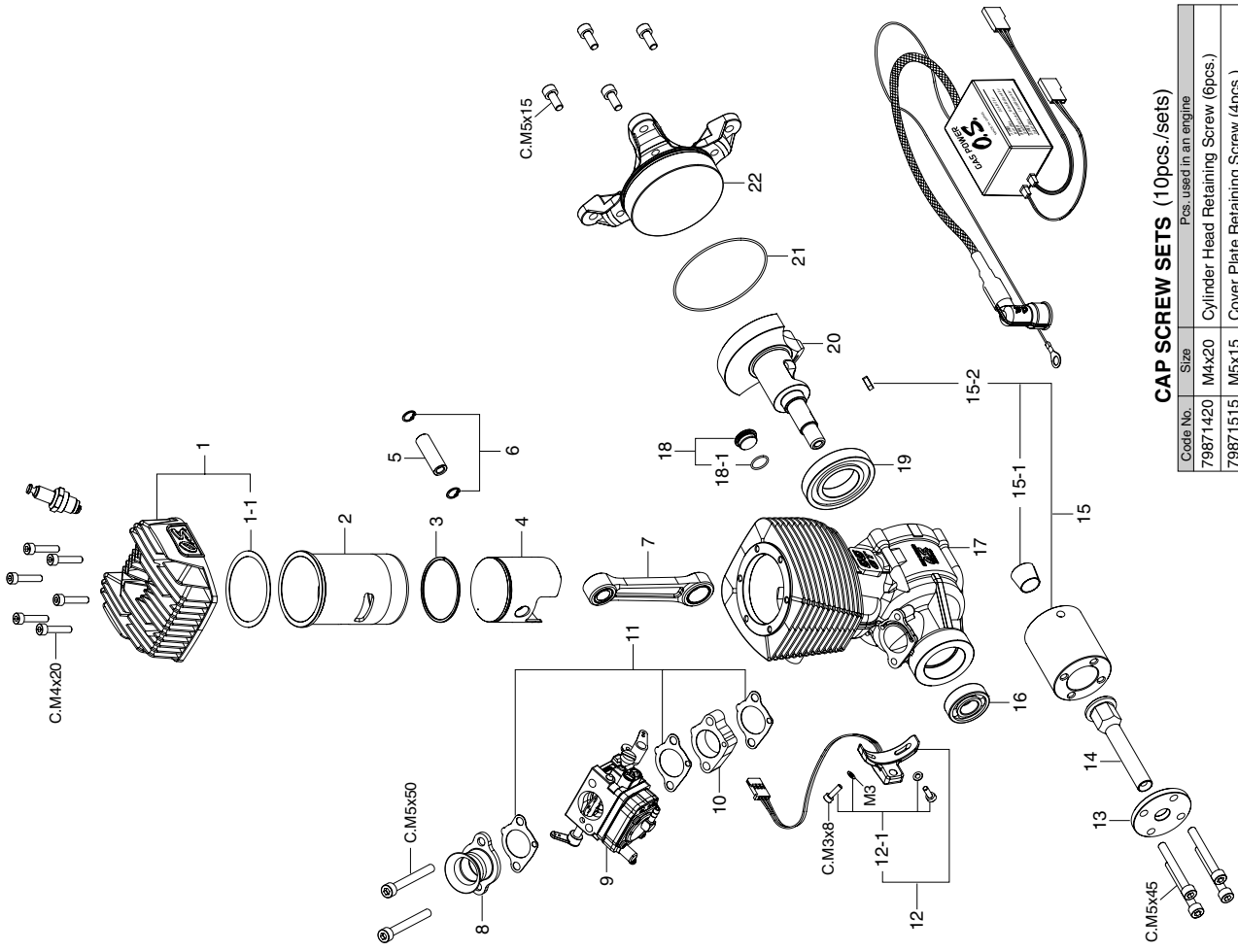

28

ENGINE PARTS LIST

No.	Code No.	Description
1	29704000	Cylinder Head
1-1	29714100	Head Gasket
2	29703100	Cylinder Liner
3	29703400	Piston Ring
4	29703200	Piston
5	29706000	Piston Pin
6	29717000	Piston Pin Retainer
7	29705000	Connecting Rod
8	29781300	Velocity Stack
9	29781000	Carburetor Complete (WLA-2)
10	29781100	Carburetor Insulator
11	29781500	Carburetor Gasket Set
12	29701200	Rotation Sensor
12-1	29701210	Rotation Sensor Retaining Screw Set
13	29709000	Propeller Washer
14	29702100	Pilot Shaft
15	29708000	Drive Spacer
15-1	29708100	Taper Collet
15-2	29708200	Pararel Key
16	29730000	Ball Bearing (F)
17	29701000	Crankcase
18	29701300	Crankcase Plug
18-1	29701310	"O" Ring
19	29731000	Ball Bearing (R)
20	29702000	Crankshaft
21	29714200	Cover Gasket
22	29707000	Cover Plate
	74002000	Ignition Module (IG-01)
	74002200	Plug Cap Set
	71669000	Spark Plug CM-6
	29714300	Exhaust Gasket GT55

The specifications are subject to alteration for improvement without notice.

* Type of screw C...Cap Screw

CAP SCREW SETS (10pcs./sets)

Code No.	Size	Pos. Used in an engine
79871420	M4x20	Cylinder Head Retaining Screw (6pcs.)
79871515	M5x15	Cover Plate Retaining Screw (4pcs.)
79871545	M5x45	Propeller Washer Retaining Screw (4pcs.)
79871550	M5x50	Velocity Stack Retaining Screw (2pcs.)

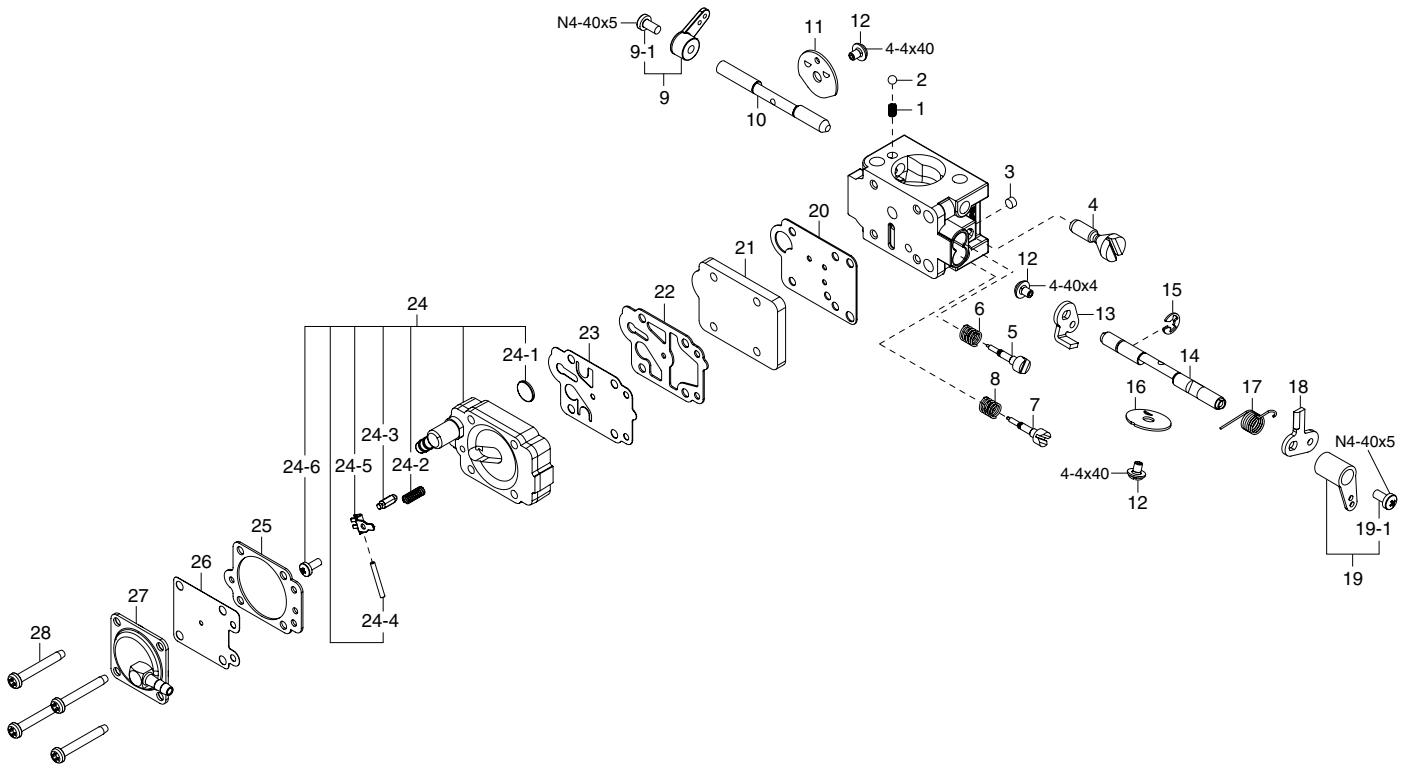

*Type of screw N...Round Head Screw

No.	Code No.	Description
1	29781340	Spring-Choke Friction
2	29781330	Ball
3	29781460	Plug-Friction
4	29781450	Screw-Idle Speed
5	29781430	Needle-High Speed
6	29781440	Spring-Needle (H) ADJ.
7	29781410	Needle-Idle
8	29781420	Spring-Needle ADJ.
9	29781360	Choke Arm Assy
9-1	29781350	N4-40x5 Retaining Screw
10	29781310	Shaft-Choke
11	29781320	Valve-Choke
12	29781570	4-40x4 Retaining Screw
13	29781550	Lever-Outer
14	29781510	Shaft-Throttle
15	29781560	Ring-Retaining
16	29781520	Valve-Throttle
17	29781530	Spring-Throttle Return
18	29781540	Link-Throttle
19	29781370	Throttle Arm Assy
19-1	29781350	N4-40x5 Retaining Screw

No.	Code No.	Description
20	29781020	Gasket Passage
21	29781030	Plate-Passage
22	29781040	Gasket-Pump
23	29781050	Diaphragm-Pump
24	29781270	Body Assembly Pump
24-1	29781060	Screen-Inlet
24-2	29781210	Spring-Metering
24-3	29781220	Valve Inlet Needle
24-4	29781230	Pin-Metering Lever
24-5	29781240	Lever-Metering
24-6	29781250	Screw-Metering
25	29781120	Gasket-Metering Diaphragm
26	29781130	Diaphragm Assembly-Metering
27	29781140	Cover Assembly-Metering (W/Nipple)
28	29781070	Carb. Assemble Screw

The specifications are subject to alteration for improvement without notice.

■ **GT55 SILENCER TYPE1 (E-6010)**
With Plain Washer M5 (2pcs.)
(74003010)

- Cap Screw M5x50 (10pcs./sets)
(79871550)
- Lock Washer M5 (10sets)
(55500004)

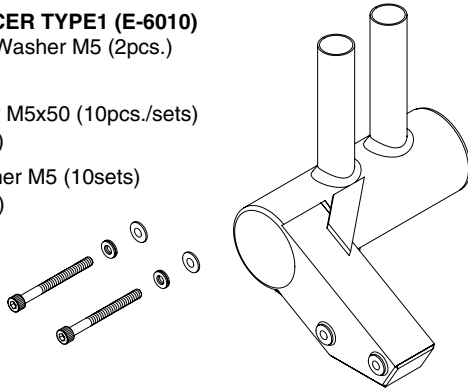

■ **M5 STAND OFF ENGINE MOUNTS**

Code No.	Description
74003510	M5 Stand Off Engine Mount 1/4" (6.4mm) (4pcs.)
79871530	Hex Socket Head Bolt M5x30 (10pcs./sets)
79870050	Blind Nut M5 (10pcs./sets)
74003520	M5 Stand Off Engine Mount 1/2" (12.7mm) (4pcs.)
79871535	Hex Socket Head Bolt M5x35 (10pcs./sets)
79870050	Blind Nut M5 (10pcs./sets)
74003530	M5 Stand Off Engine Mount 3/4" (19.1mm) (4pcs.)
79871545	Hex Socket Head Bolt M5x45 (10pcs./sets)
79870050	Blind Nut M5 (10pcs./sets)

Code No.	Description
74003540	M5 Stand Off Engine Mount 1" (25.4mm) (4pcs.)
79871515	Hex Socket Head Bolt M5x15 (10pcs./sets)
79871520	Hex Socket Head Bolt M5x25 (10pcs./sets)
55500004	Lock Washer M5 (10sets)
21109005	Propeller Washer \varnothing 18
74003550	M5 Stand Off Engine Mount 1-1/4" (31.8mm) (4pcs.)
79871515	Hex Socket Head Bolt M5x15 (10pcs./sets)
79871520	Hex Socket Head Bolt M5x25 (10pcs./sets)
55500004	Lock Washer M5 (10sets)
21109005	Propeller Washer \varnothing 18
74003560	M5 Stand Off Engine Mount 1-1/2" (38.1mm) (4pcs.)
79871515	Hex Socket Head Bolt M5x15 (10pcs./sets)
79871520	Hex Socket Head Bolt M5x25 (10pcs./sets)
55500004	Lock Washer M5 (10sets)
21109005	Propeller Washer \varnothing 18
74003570	M5 Stand Off Engine Mount 1-3/4" (44.5mm) (4pcs.)
79871515	Hex Socket Head Bolt M5x15 (10pcs./sets)
79871520	Hex Socket Head Bolt M5x25 (10pcs./sets)
55500004	Lock Washer M5 (10sets)
21109005	Propeller Washer \varnothing 18
74003580	M5 Stand Off Engine Mount 2" (50.8mm) (4pcs.)
79871515	Hex Socket Head Bolt M5x15 (10pcs./sets)
79871520	Hex Socket Head Bolt M5x25 (10pcs./sets)
55500004	Lock Washer M5 (10sets)
21109005	Propeller Washer \varnothing 18

■ **SUPER FILTER (S)**
(72403051)



■ **SUPER FILTER (L)**
(72403050)



■ **NON-BUBBLE WEIGHT (S)**
(71531010)



■ **BLIND NUT (10pcs.)**
M5
(79870050)



■ **LOCK WASHER (10sets)**

M5
(55500004)



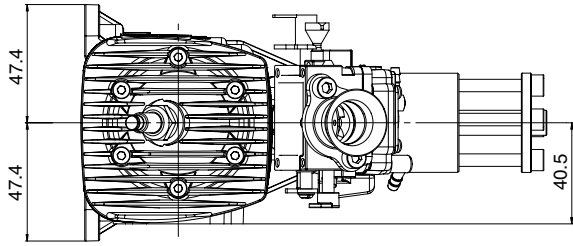

Specifications

■ Displacement	54.93 cc / 3.352 cu.in.
■ Bore	41.2 mm / 1.62 in.
■ Stroke	41.2 mm / 1.62 in.
■ Practical R.P.M.	1,500-8,000 r.p.m.
■ Output	5.5 ps / 5.58 hp / 7,000r.p.m.
■ Weight	1580 g / 55.7 oz. (Engine) 140 g / 4.94 oz. (Ignition Module)

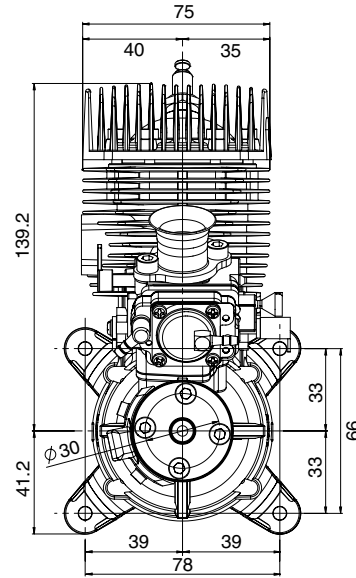
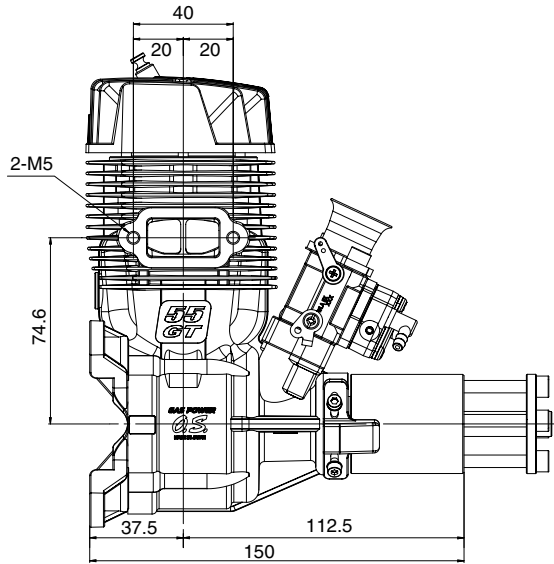

Dimensions (mm)

