

O.S. ENGINE

The engine is designed to use
the O.S. Bio-Ethanol fuel only.

MAX-75AX-BE

INSTRUCTION MANUAL

It is of vital importance, before attempting to operate your engine, to read the general 'SAFETY INSTRUCTIONS AND WARNINGS' section on pages 2-6 of this booklet and to strictly adhere to the advice contained therein.

- Also, please study the entire contents of this instruction manual, so as to familiarize yourself with the controls and other features of the engine.
- Keep these instructions in a safe place so that you may readily refer to them whenever necessary.
- It is suggested that any instructions supplied with the aircraft, radio control equipment, etc., are accessible for checking at the same time.

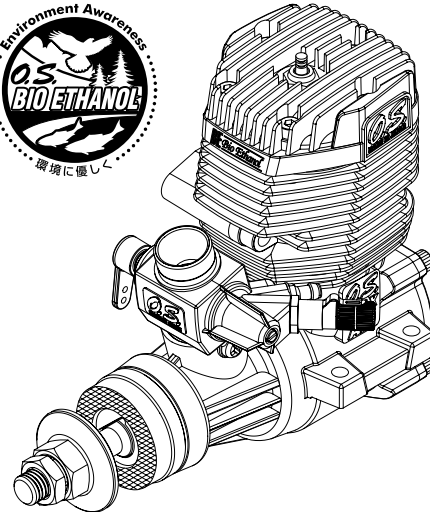

O.S. ENGINE

CONTENTS

SAFETY INSTRUCTIONS AND WARNINGS ABOUT YOUR O.S. ENGINE -----	2-6	STARTING -----	24-27
ENGINE CONSTRUCTION, NOTES WHEN APPLYING AN ELECTRIC STARTER ---	7-8	RUNNING -IN, IDLING ADJUSTMENT CHART ----	28-31
ABOUT THE ENGINE -----	9	MIXTURE CONTROL VALVE ADJUSTMENT -----	32
BASIC ENGINE PARTS-----	10	REALIGNMENT OF MIXTURE CONTROL VALVE, SUBSEQUENT STARTINGPROCEDURE -----	33
BEFORE STARTING -----	11-14	TROUBLE SHOOTING WHEN THE ENGINE FAILS TO START -----	34-35
INSTALLATION -----	15-17	CARE AND MAINTENANCE -----	36-37
INSTALLATION OF THE STANDARD ACCESSORIES ---	18-19	ENGINE EXPLODED VIEW & PARTS LIST -----	38-39
FUEL TANK LOCATION -----	20-21	CARBURETOR EXPLODED VIEW & PARTS LIST ----	40-41
MIXTURE CONTROLS -----	22	O.S. GENUINE PARTS & ACCESSORIES ----	42-43
GLOWPLUG -----	23	THREE VIEW DRAWING -----	44

SAFETY INSTRUCTIONS AND WARNINGS ABOUT YOUR O.S. ENGINE

Remember that your engine is not a "toy", but a highly efficient internal-combustion machine whose power is capable of harming you, or others, if it is misused.

As owner, you, alone, are responsible for the safe operation of your engine, so act with discretion and care at all times.

If at some future date, your O.S. engine is acquired by another person, we would respectfully request that these instructions are also passed on to its new owner.

■ The advice which follows is grouped under two headings according to the degree of damage or danger which might arise through misuse or neglect.



WARNINGS

These cover events which might involve serious (in extreme circumstances, even fatal) injury.



NOTES

These cover the many other possibilities, generally less obvious sources of danger, but which, under certain circumstances, may also cause damage or injury.

2



WARNINGS

- Never touch, or allow any object to come into contact with, the rotating propeller and do not crouch over the engine when it is running.



- A weakened or loose propeller may disintegrate or be thrown off and, since propeller tip speeds with powerful engines may exceed 600 feet(180 metres) per second, it will be understood that such a failure could result in serious injury, (see 'NOTES' section relating to propeller safety).

- O.S. Bio - Ethanol fuel is not poisonous but harmful. Do not allow it to be swallowed. Always store it in a clearly marked container and out of the reach of children.

- Model engine fuel is also highly flammable. Keep it away from open flame, excessive heat, sources of sparks, or anything else which might ignite it. Do not smoke or allow anyone else to smoke, near to it.



- Never operate your engine in an enclosed space. Model engines, like automobile engines, exhaust deadly carbon-monoxide. Run your engine only in an open area.

- Model engines generate considerable heat. Do not touch any part of your engine until it has cooled. Contact with the muffler (silencer), cylinder head or exhaust header pipe, in particular, may result in a serious burn.



3



NOTES

- This engine was designed for model aircraft. Do not attempt to use it for any other purpose.
- Mount the engine in your model securely, following the manufacturers' recommendations, using appropriate screws and lock-nuts.
- Be sure to use the silencer (muffler) supplied with the engine. Frequent exposure to an open exhaust may eventually impair your hearing. Such noise is also likely to cause annoyance to others over a wide area.
- If you remove the glowplug from the engine and check its condition by connecting the battery leads to it, do not hold the plug with bare fingers. Use an appropriate tool or a folded piece of cloth.
- Install a top-quality propeller of the diameter and pitch specified for the engine and aircraft. Locate the propeller on the shaft so that the curved face of the blades faces forward-i.e. in the direction of flight. Firmly tighten the propeller nut, using the correct size wrench.



NOTES

- Always check the tightness of the propeller nut and retighten it, if necessary, before restarting the engine. Also, check the tightness of all the screws and nuts before restarting the engine.
- If you install a spinner, make sure that it is a precision made product and that the slots for the propeller blades do not cut into the blade roots and weaken them.
- Preferably, use an electric starter. The wearing of safety glasses is also strongly recommended.
- Discard any propeller which has become split, cracked, nicked or otherwise rendered unsafe. Never attempt to repair such a propeller: destroy it. Do not modify a propeller in any way, unless you are highly experienced in tuning propellers for specialized competition work such as pylon-racing.
- Take care that the glow plug clip or battery leads do not come into contact with the propeller. Also check the linkage to the throttle arm. A disconnected linkage could also foul the propeller.
- After starting the engine, carry out any needle-valve readjustments from a safe position behind the rotating propeller. Stop the engine before attempting to make other adjustments to the carburetor.



NOTES

- Adjust the throttle linkage so that the engine stops when the throttle stick and trim lever on the transmitter are fully retarded. Alternatively, the engine may be stopped by cutting off the fuel supply. Never try to stop the engine physically.
- Take care that loose clothing (ties, shirt sleeves, scarves, etc.) do not come into contact with the propeller. Do not carry loose objects (such as pencils, screwdrivers, etc.) in a shirt pocket from where they could fall through the propeller arc.
- Do not start your engine in an area containing loose gravel or sand. The propeller may throw such material in your face and eyes and cause injury.
- For their safety, keep all onlookers (especially small children) well back (at least 20 feet or 6 meters) when preparing your model for flight. If you have to carry the model to the take-off point with the engine running, be especially cautious. Keep the propeller pointed away from you and walk well clear of spectators.
- Warning! Immediately after a glowplug-ignition engine has been run and is still warm, conditions sometimes exist whereby it is just possible for the engine to abruptly restart if the propeller is casually flipped over compression WITHOUT the glowplug battery being reconnected. Remember this if you wish to avoid the risk of a painfully rapped knuckle!

6

OS.ENGINE

ENGINE CONSTRUCTION

With this engine, the piston will feel tight at the top of its stroke (TDC) when the engine is cold. This is normal. The cylinder bore has a slight taper. The piston and cylinder are designed to achieve a perfect running clearance when they reach operating temperature.

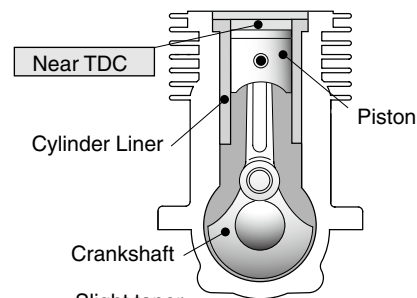

Slight taper

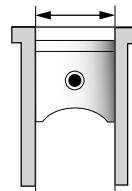
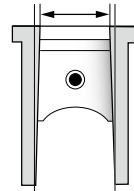

When the engine is cold. When the engine is hot.

7

NOTES WHEN APPLYING AN ELECTRIC STARTER

Do not over-prime. This could cause a hydraulic lock and damage the engine on application of the electric starter.

If over-primed, remove glowplug, close needle-valve and apply starter to pump out surplus fuel. Cover the head with a rag to prevent pumped out fuel from getting into your eyes.

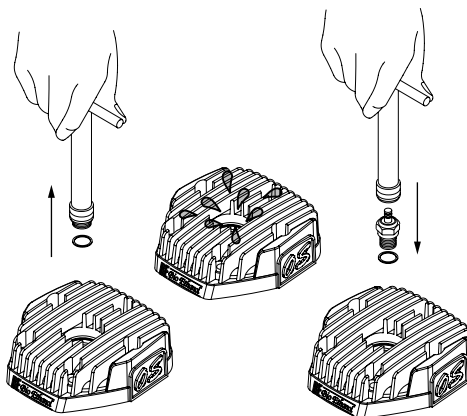



ABOUT THE ENGINE

The MAX-75AX-BE has been developed and designed to use O.S. Bio-Ethanol fuel only. Therefore, some parts are different from those of the MAX-75AX that use conventional methanol based glow fuel. Also, special attention is required in it's handling.

- This engine has been developed based on the MAX-75AX, to use only O.S. Bio-Ethanol fuel. It develops enough power to fly general 61 size sport models.
- It is suggested to use propellers which develop maximum r.p.m. of 8,500~9,500 so that you may enjoy pleasant exhaust sound keeping it low.
- Glow plug, cylinder head, carburetor, drive hub and silencer are different from those of the MAX-75AX.

STANDARD ACCESSORIES

- Glow Plug BE-3 (supplied with the engine) 
- Needle Valve Extension Cable Set 
- E-4040 Silencer Assembly
· Silencer Retaining Screw (M4x40 2pcs.)

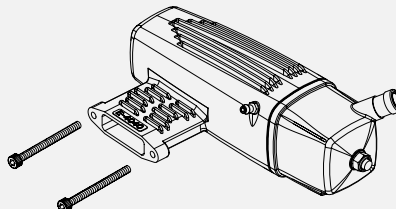

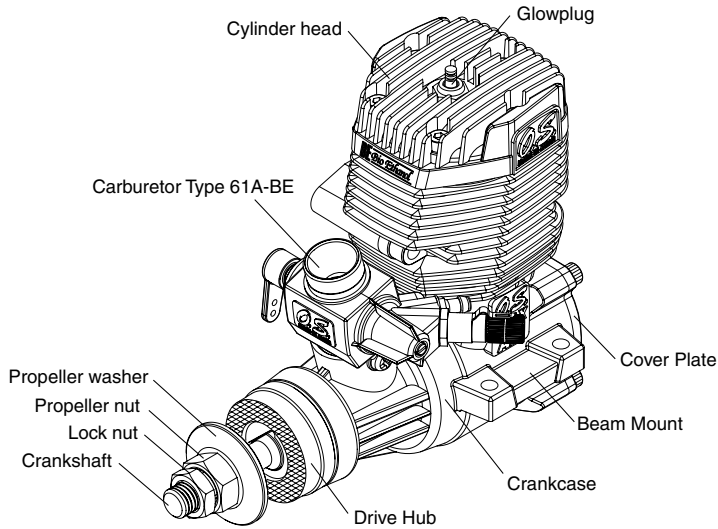

Tools, accessories, etc. The following items are necessary for operating the engine.

Propellers



The choice of propeller depends on the design and weight of the aircraft and the type of flying in which you will be engaged. Determine the best size and type after practical experimentation. As a starting point, refer to the props listed in the accompanying table. Slightly larger, or even slightly smaller, props than those shown in the table may be used, but remember that the propeller noise will increase, due to higher rpm or if a larger-diameter/lower-pitched prop is used.

Sport	13x9-10, 14x6-8, 15x6
-------	-----------------------

It is suggested to use propellers which develop maximum r.p.m. of 8,500~9,500 so that you may enjoy pleasant exhaust sound keeping it low.

Warning:

Make sure that the propeller is well balanced. An unbalanced propeller and/or spinner can cause serious vibration which may weaken parts of the airframe or affect the safety of the radio-controlled system. DO NOT forget the WARNINGS and NOTES on propeller and spinner safety given on front pages.

Reminder!

 **Never touch, or allow any object to come into contact with, the rotating propeller and do not crouch over the engine when it is running.**

Spinner



Since the 75AX-BE is intended to be started with an electric starter, the addition of a spinner assembly for centering the starter sleeve is desirable. Use a heavy-duty, well balanced spinner either of metal or plastic.



FUEL

Use the O.S. Bio-Ethanol fuel (BE-1). Other fuel cannot be used with this engine. Do not use conventional methanol based glow fuel, or the engine will not run properly and strong knocking may occur, which may cause the propeller to fly off.

Reminder!

-  **O.S. Bio-Ethanol fuel is not poisonous but harmful. Do not allow it to be swallowed. Always store it in a clearly marked container and out of the reach of children.**
-  **Model engine fuel is also highly flammable. Keep it away from open flame, excessive heat, sources of sparks, or anything else which might ignite it. Do not smoke, or allow anyone else to smoke, near to it.**

Fuel Tank

A fuel tank of approximately 160~180cc capacity is suggested. This allows around 10-12 minutes flying time, dependent upon, the size of propeller and on the amount of full-throttle to part-throttle operation throughout the flight.

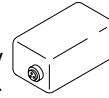

GLOW PLUG

The engine is supplied with a special glow plug (BE-3) designed for this engine. Use 1.2V~1.5V the same as conventional glow plugs. This glow plug has a different thread size for both the dia. and pitch purposely so that conventional glow plugs may not be installed.



GLOWPLUG IGNITER

Commercially available handy glowplug heater in which the glowplug battery and battery leads are integrated.

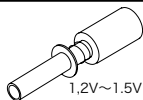

FUEL PUMP

Alternatively, one of the purpose-made manual or electric fuel pumps may be used to transfer fuel directly from your fuel container to the fuel tank.

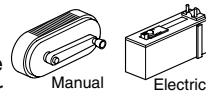

Electric Starter and Starter Battery

Required when starting the engine. 12-Volt lead-acid battery

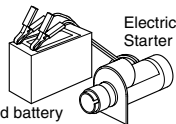

Fuel Filter

It is recommended to install a good in-line filter between the fuel tank and carburetor to prevent entry of foreign matter into the carburetor.

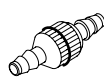

O.S. Super Filter (Fuel Can Filter)

Install a filter on the outlet tube of your refueling container to prevent entry of foreign matter into fuel tank. O.S. 'Super Filters' (large and small) are available as optional extras.



O.S. Non-Bubble Weight

To prevent the pickup from adhering to the tank wall under suction and restricting fuel flow, slots may be filed in the end of the weight. Alternatively, an O.S. Non-Bubble Weight is available as an optional extra.



SILICONE FUEL LINE

Heatproof silicone tubing of approx. 5mm o.d. and 2.5mm i.d. is required for the connection between the fuel tank and engine.

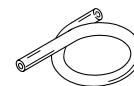

■ **TOOLS**

HEX Screwdriver

Necessary for engine installation.
1.5mm, 2.5mm



Phillips Screwdriver

No.2, etc.



SCREWDRIVER

Necessary for carburetor adjustments.

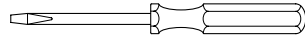

Socket Screwdriver

5mm, 5.5mm, 7mm

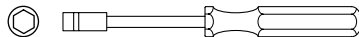

LONG SOCKET WRENCH WITH PLUG GRIP

Recommended for easy removal and replacement of the angled and recessed glowplug, the O.S. Long Socket Wrench incorporates a special grip.

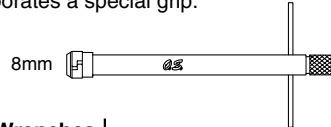

End Wrenches

12mm, 14mm etc.

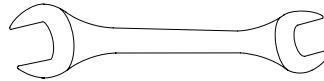

Needle Nose Pliers

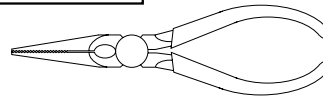

INSTALLATION

It is suggested to use as heavy and rigid as possible engine mounting for highest performance and safe running. Conventional wooden mounting beams should be of rigid hardwood and of at least 15mm or 5/8-in square section. Use at least 3mm steel screws, such as Allen type, with locknuts, for bolting the engine to the bearers..

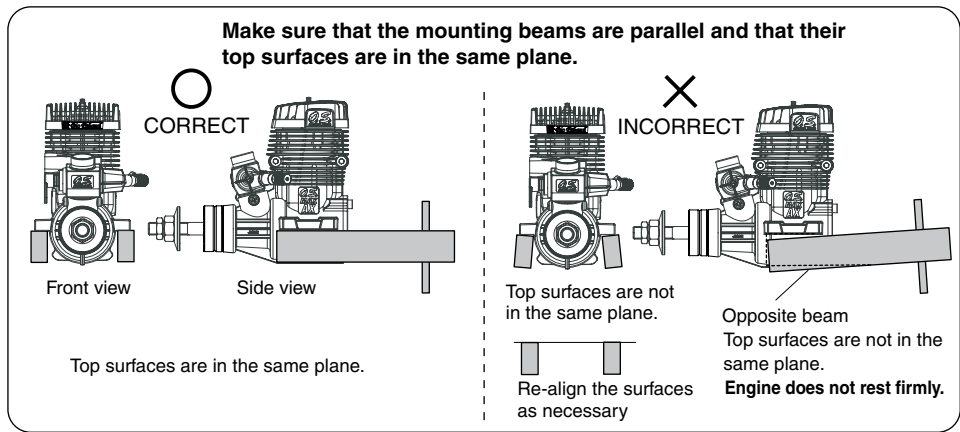

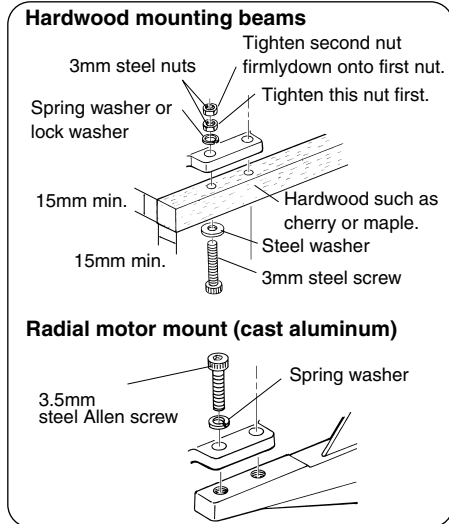
How to fasten the mounting screws.

- Make sure that these mounting beams are accurately aligned and firmly integrated with the airframe, reinforcing the adjacent structure to absorb vibration. Use 4mm or larger steel screws, preferably Allen type hexagon socket head cap screws, with washers and locknuts, for bolting the engine to the bearers.

O.S. Radial Motor Mount

A special O.S. radial motor mount (Code No.71905200) is available, as an optional extra, for use where firewall type mounting is required.

■ THROTTLE LINKAGE

Before connecting the throttle to its servo, make sure that the throttle arm and linkage safely clear any adjacent part of the airframe structure, etc., as the throttle is opened and closed. Connect the linkage so that the throttle is fully closed when the transmitter throttle stick and its trim lever are at their lowest settings and fully open when the throttle stick is in its fully-open position. Carefully align the appropriate holes in the throttle arm and servo horn so that they move symmetrically and smoothly through their full travel.

■ INSTALLING THE GLOWPLUG

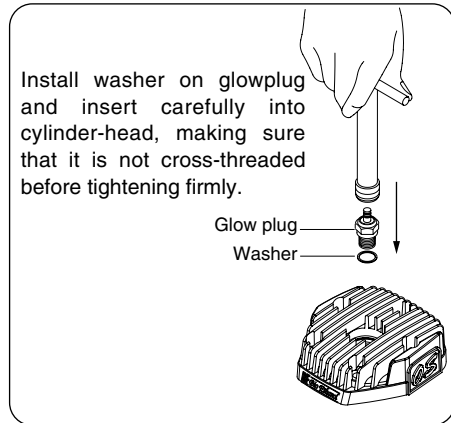

■ NEEDLE-VALVE EXTENSION

The needle-valve supplied with this engine is designed to incorporate an extension so that, when the engine is enclosed within the fuselage, the needle-valve may be adjusted from the outside. For this purpose a Needle Valve Extension Cable Set is supplied with the engine. If a longer extension is required, cut a commercially available rod to the required length, bend one end to an L shape, insert it into needle's center hole and secure it by tightening the set-screw in the needle-valve knob with 1.5mm Allen key.

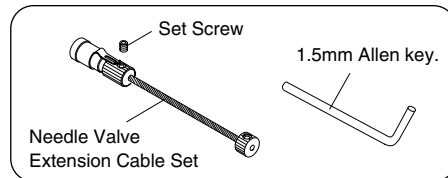

■ INSTALLING SILENCER

Secure the silencer to the engine by means of two retaining screws supplied after the engine is securely mounted to a test bench or a model.

The exhaust outlet of the silencer can be rotated by 90 degrees the following manner:

- 1) Loosen the locknut and assembly screw.
- 2) Set the exhaust outlet at the required position by rotating the rear part of the silencer.
- 3) Re-tighten the assembly screw, followed by the locknut.

It is recommended to seal the fitting faces of engine exhaust and silencer with silicone sealant.

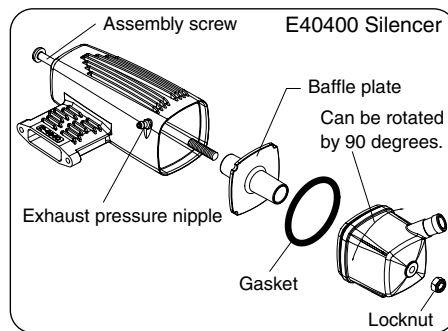

Reminder!

Model engines generate considerable heat. Do not touch any part of your engine until it has cooled. Contact with the muffler (silencer), cylinder head or exhaust header pipe, in particular, may result in a serious burn. Keep your hands and face away from exhaust gas or you will suffer a burn.

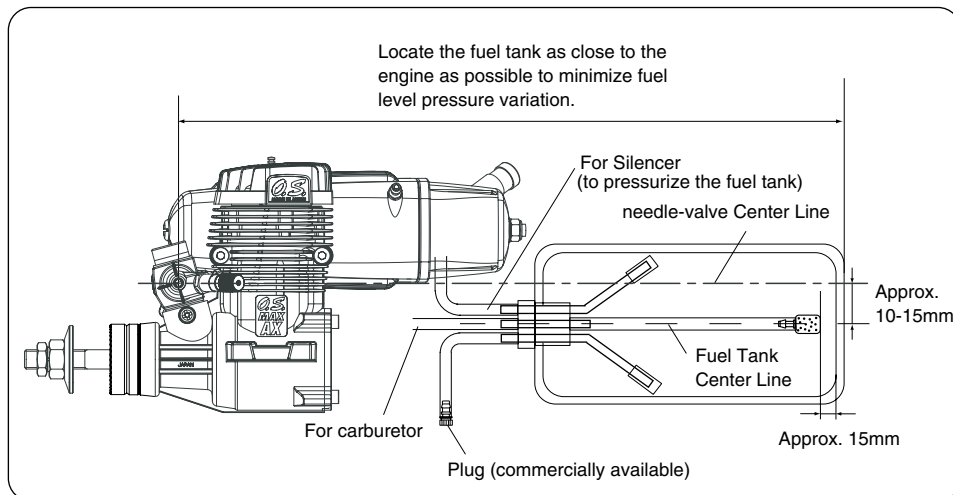

- Suggested fuel tank capacity is approx 160-180cc. This will allow 10-12 minute flights.
- Make sure that the tank is well rinsed out with methanol or glow fuel before installation and that the pickup weight is well clear of the bottom of the tank when held vertically.
- Use a suitable length of best quality 5mm OD x 2.5mm ID silicone tubing for fuel tubing.
- Fuel line weight should be 10mm away from the tank bottom.
- Locate the fuel tank so that the center line of the tank is 10 to 15mm below the center line of the needle-valve.
- Be sure to use a pressurized fuel system by connecting the muffler pressure nipple to the vent-pipe of the fuel tank.

Attention to tank height

Two mixture controls are provided on this Carburetor.

• **The Needle Valve**

When set to produce maximum power at full throttle, this establishes the basic fuel/air mixture strength. The correct mixture is then maintained by the carburetor's built-in automatic mixture control system to cover the engine's requirements at reduced throttle settings.

• **The Mixture Control Valve**

This meters fuel flow at part-throttle and idling speeds to ensure reliable operation as the throttle is opened and closed. The Mixture Control Valve is factory set for the approximate best result. First run the engine as received and readjust the Mixture Control Screw only if necessary.

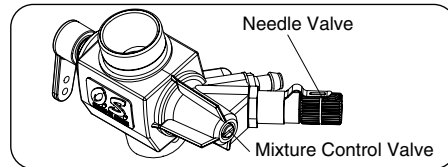

Mixture Control Valve of the carburetor is set at basic position (a little on the rich side) at the factory. However, minor readjustment will be required for atmospheric conditions and a model. When a good result is not obtained with the factory setting, readjust it according to the MIXTURE CONTROL VALVE ADJUSTMENT section. Please note during a running-in period flights should be made with a slightly rich needle setting. Therefore, during a running-in period proper carburetor responses will not be obtained. Adjust it at optimum position after the running-in is completed.



An O.S. BE-3 glowplug is supplied with the engine. Use only the O.S. BE-3 as replacement. Carefully install plug finger-tight, before final tightening with the correct size plug wrench.

Glowplug life

- Be sure to disconnect the plug leads when adjusting the needle-valve at higher r.p.m. range.
- Do not run the engine too lean and do not leave the battery connected while adjusting the needle.

The role of the glowplug

With a glowplug engine, ignition is initiated by the application of a 1.5-volt power source. When the battery is disconnected, the heat retained within the combustion chamber remains sufficient to keep the plug filament glowing, thereby continuing to keep the engine running. Ignition timing is 'automatic' : under reduced load, allowing higher rpm, the plug becomes hotter and, appropriately, fires the fuel/air charge earlier; conversely, at reduced rpm, the plug become cooler and ignition is retarded.

When to replace the glowplug

Apart from when actually burned out, a plug may need to be replaced because it no longer delivers its best performance, such as when:

- Filament surface has roughened and turned white.
- Filament coil has become distorted.
- Foreign matter has adhered to filament or plug body has corroded.
- Engine tends to cut out when idling.
- Starting qualities deteriorate.

Be sure to use an electric starter to start the engine.



Never fail to check the tightness of screws and nuts, especially engine mounting and moving parts (e.g. throttle lever).

Starting procedure is as follows:

1. Fill the fuel tank with fuel. When filled, prevent fuel flowing into the carburetor with a commercially available fuel stopper, etc. Release the stopper before starting the engine.
2. Make sure that plug element glows red, and install the plug in the cylinder head.

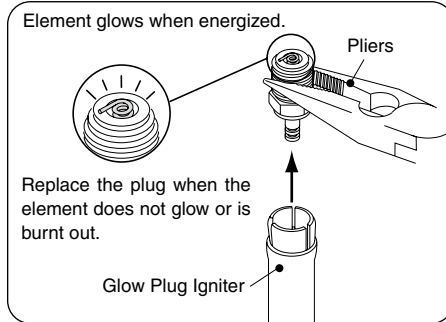

WARNING

When checking the plug element hold the plug with tools, such as pliers, etc. Do not hold near your face or the fuel remaining in the filament may burn you.

3. Check that the needle-valve is closed. (Do not overtighten.) Now open the needle-valve counter-clockwise 4.5-5 turns to the starting setting.

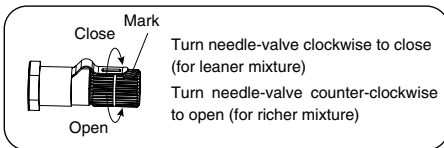

4. Set the throttle at 1/2 open and apply the starter and press the starter switch for 5-6 seconds to prime the engine.

Attention :

Do not choke the carburetor air intake when applying the starter. This could cause an excessive amount of fuel to be drawn into the cylinder which may initiate a hydraulic lock and damage the engine.

5. Open the throttle approx. one-quarter.

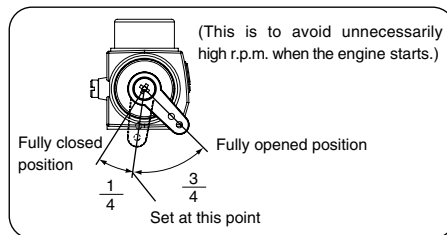

6. Connect battery leads to glowplug.

7. Bring electric starter into contact with spinner-nut or spinner and depress starter switch for a short time. Repeat if necessary. When the engine starts, withdraw the starter immediately.

OS ENGINE

When the engine is started, open the throttle slowly and adjust for the maximum r.p.m.

With this needle-valve setting, the mixture is fairly rich. Close the needle-valve gradually until just short of the peak r.p.m. Disconnect the plug leads and further close the needle-valve to the optimum position.

Then, close the throttle to idle, and open smoothly to maximum r.p.m. If the r.p.m. increases smoothly to maximum r.p.m., the needle setting is OK.

If not, the needle setting is still rich. Close the needle-valve further (10~15 degrees at a time), and check the maximum r.p.m. If the needle-valve is closed too much, the engine will not accelerate and the r.p.m. decrease or the engine will stop.

It is necessary to warm the engine up well so that the fuel may vaporize sufficiently in order for the engine to run steadily at maximum r.p.m. When the temperature is lower (below 10°C), it will take some time for the engine to be warmed up. Adjust the needle-valve until the engine is sufficiently warmed up and r.p.m. changes smoothly in proportion with the throttle opening and closing.

The 75AX-BE requires some patience when adjusting, so become acquainted with the needle-valve setting procedure described above.

Open the needle-valve 1/2~1 turn when restarting the engine after the flight. Then, start the engine and adjust the needle-valve after warming the engine well up. (Longer warning up time is required when the temperature is low, while shorter warning up time is required when the temperature is high.)

26

OS ENGINE

Once the optimum needle-valve is set, there will be no need to change the setting in the same day unless atmospheric conditions change a lot. The optimum setting may vary slightly according to the temperature and atmospheric conditions.

Note:

Readjustments are required when a propeller is changed even with a same size of the same brand.

Note:

Until the engine warms up sufficiently, the engine tends to stall or quit when the throttle is opened before reaching the maximum r.p.m. This is because the 75AX-BE consumes much less fuel and the fuel is not vaporized sufficiently.

How to stop the engine

Pull down the throttle lever and trim lever on the transmitter fully.

Note:

Make sure that the throttle linkage is made so that the throttle is fully closed when the throttle lever as well as trim lever on the transmitter are fully pulled down.

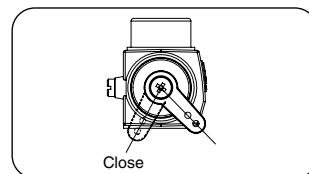

27

All internal-combustion engines benefit from extra care when they are run for the first few times known as running-in or breaking-in.

This allows the working parts to mate together under load at operating temperature. Therefore, it is vitally important to complete the break-in before allowing the engine to run continuously at high speed and before finalizing carburetor adjustments.

However, because O.S. engines are produced with the aid of the finest modern precision machinery and from the best and most suitable materials, only a short and simple running-in procedure is called for and can be carried out with the engine installed in the model.

The process is as follows.

1. Install the engine with the propeller intended for your model. Open the needle-valve to the advised starting setting and start the engine. If the engine stops when the glow plug battery is disconnected, open the needle-valve to the point where the engine does not stop. Run the engine for one minute with the throttle fully open, but with the needle-valve adjusted for rich, slow "four-cycle" operation.
2. Now close the needle-valve until the engine speeds up to "two-cycle" operation and allow it to run for about 10 seconds, then reopen the needle-valve to bring the engine back to "four-cycle" operation and run it for another 10 seconds. Repeat this procedure until the fuel tank is empty.

3. Re-start and adjust the needle-valve so that the engine just breaks into a "two-cycle" from "four-cycle" operation, then make three or four flights, avoiding successive "nose-up" flights.

4. During subsequent flights, the needle-valve can be gradually closed to give more power. However, if the engine shows signs of running too lean, the next flight should be set richer. After a total of ten flights, the engine should run continuously, at its optimum needle-valve setting, without loss of power as it warms up.

5. After the completion of the running-in adjust the carburetor at optimum setting referring to MIXTURE CONTROL VALVE ADJUSTMENT section and SUBSEQUENT READJUSTMENT section.

Optimum needle setting(1)

Slowly advance the throttle to its fully open position, then gradually close the needle-valve until the exhaust note begins to change. (4-cycle to 2-cycle)

Optimum needle setting(2)

As the needle-valve is closed slowly and gradually, the engine r.p.m. will increase and a continuous high-pitched exhaust note, only, will be heard. Close the needle-valve 10-15 degrees and wait for the change of r.p.m.

After the engine r.p.m. increases turn the needle-valve another 10-15 degrees and wait for the next change of r.p.m. As the speed of the engine does not instantly change with needle-valve readjustment, small movements, with pauses between, are necessary to arrive at the optimum setting.

Needle-valve adjustment diagram

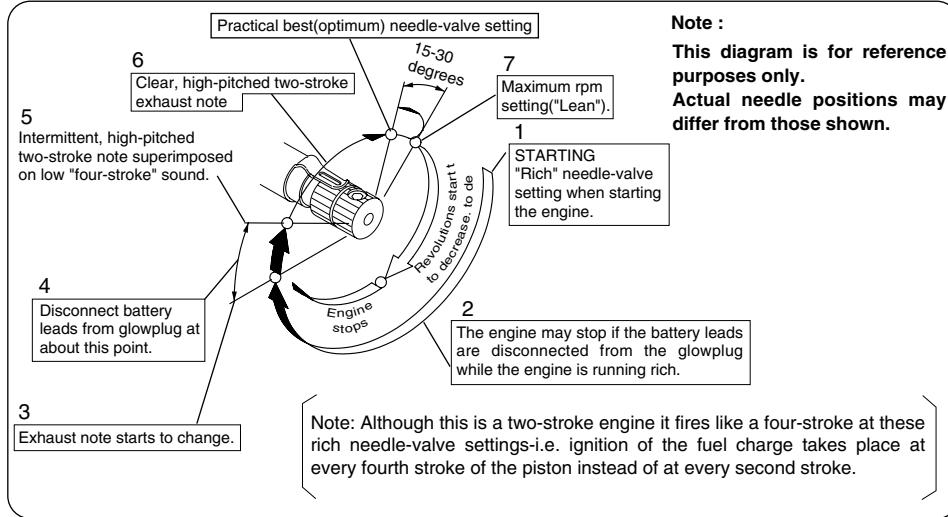

OS.ENGINE **IDLING ADJUSTMENT CHART**

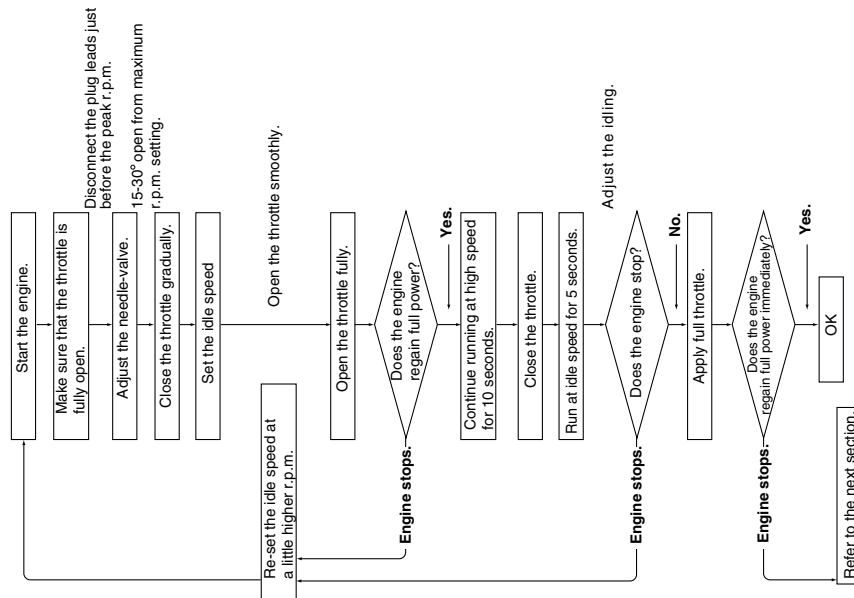

MIXTURE CONTROL VALVE ADJUSTMENT

- With the engine running, close the throttle and allow it to idle for about five seconds, then open the throttle fully. If, at this point, the engine hesitates to pick up with thick sound, the mixture is too rich. Correct this condition by turning the Mixture Control Screw clockwise 15-30 degrees.
- If the mixture is excessively rich, the engine may stop suddenly before picking up when the throttle is fully opened, or with prolonged idling the engine r.p.m. will drop gradually and the engine stop.
- If, on the other hand, the mixture is too lean, the r.p.m. will not increase with a weak sound or drop after increasing for a short time and stop. In this case, turn the Mixture Control Screw counter-clockwise 90 degrees to positively enrich the idle mixture, then turn

the screw clockwise gradually until the engine retains full power cleanly when the throttle is reopened.

- If the mixture is excessively lean, the r.p.m. will increase gradually, then the engine stop.

Note: Mixture Control Valve adjustments should be made in steps of 15~30 degrees initially, carefully checking the effect, on throttle response, of each small adjustment. Carrying out adjustments patiently until the engine responds quickly and positively to the throttle control.

REALIGNMENT OF MIXTURE CONTROL VALVE

In the course of making carburetor adjustments, it is just possible that the Mixture Control Valve may be inadvertently screwed in or out too far and thereby moved beyond its effective adjustment range. The basic position can be found in the sketch shown below.

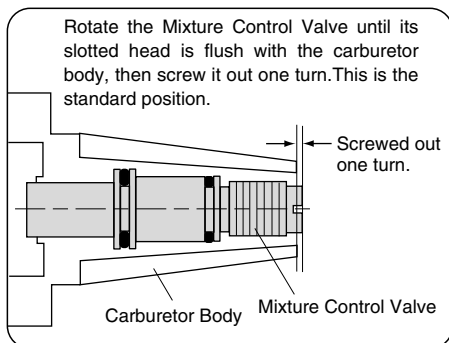

SUBSEQUENT STARTING PROCEDURE

Once the optimum needle-valve setting has been established (see page 30, Needle-valve adjustment diagram) the procedure for starting may be simplified as follows.

1. Open the needle-valve 1/2~1 turn from the optimum setting.
2. Set the throttle one-quarter open from the fully closed position, energize the glowplug and apply the electric starter. When the engine starts, re-open the throttle and re-adjust the needle-valve to the optimum setting.
3. When re-starting the engine, take the same procedure. Needle opening may vary to temperature, humidity and season.

Four key points

For quick, reliable starting, the following four conditions are required.

- ① **Good compression.**
- ② **Adequate "glow" at glowplug.**
- ③ **Correct mixture.**
- ④ **Sufficient electric starter rotating speed.**

If the engine fails to start, or does not keep running after being started, check symptoms against the following chart and take necessary corrective action.

Note: The most common causes of trouble are marked with three asterisks, the less common problems with one or two asterisks.

Symptom	Factor	Cause	Corrective action
Engine fails to fire.	①	★ Sluggish rotation	Recharge the electric starter battery.
		★★ Glowplug battery discharged.	Recharge lead-acid cell or replace dry battery. (Note: An unused, or almost unused, dry battery may sometimes be of insufficient capacity if it is "old stock".)
	②	★ Glowplug element is burned out	Replace glowplug. Check that applied voltage is not too high.
		★ Something wrong with battery leads.	Check glowplug heating using other leads.
	③	★★ Engine "flooded" due to excessive priming.	Close needle-valve fully and remove glowplug, then flip propeller to pump out excess fuel. (Invert engine, if possible, while pumping out excess). Re-start engine. (Priming is not necessary at this time.)
		★ Insufficient priming.	Repeat priming procedure referring to Priming.

Symptom	Factor	Cause	Corrective action
Engine fires intermittently but does not run.	②	★★ Incorrect heating of glowplug.	Voltage too high or too low. Re-check and readjust referring to "BEFORE STARTING" .
		★★ Over priming.	Continue applying an electric starter. If the engine does not start after more than 4 tries, disconnect the current to the glowplug and leave for a few minutes., then re-energize plug and apply starter. If the engine still does not start, remove glowplug and pump out excess fuel by applying the starter.
	①	★ Sluggish rotation.	Then re-start. (Priming is not necessary.) Recharge the electric starter battery.
Engine fires once or twice, then fails to fire.	②	★★ Glowplug battery discharged.	Recharge lead-acid cell or replace dry battery. (Note: An unused, or almost unused, dry battery may sometimes be of insufficient capacity if it is "old stock".)
Engine starts but rpm decreases and engine eventually stops.	③	★★ Insufficient priming.	Repeat priming procedure referring to Priming.
Engine starts, rpm increases and engine cuts out.	③	★★★ Mixture too rich.	Close needle-valve half turn (180°) and wait for several minutes then re-start.(Priming is not necessary.)
Engine stops when the current to the glowplug is disconnected after starting	③	★ Fuel not reaching the engine.	Make sure that tank is filled with fuel. Check that there is not something wrong with the fuel line (kinked or split). Check that carburettor is not clogged with dirt.
	③	★★ Mixture too rich.	Close the needle-valve a little before disconnecting current to the glowplug.
	②	★ Deterioration of glowplug and/or fuel	Change fuel or glowplug.

Please pay attention to the matters described below to ensure that your engine serves you well in regard to performance, reliability and long life.

- As previously mentioned, it is vitally important to avoid operating the engine in conditions where dust, disturbed by the propeller, may be deposited on the engine and enter its working parts.
- Remember to keep your fuel container closed to prevent foreign matter from contaminating the fuel. Once opened, fuel deteriorates as days go by. Use up as soon as possible after opening the container. Also, keep it cool and in a dark place.

- Install a fuel filter to prevent foreign matter in the fuel container from entering the fuel tank. O.S. Super Filters (L) and (S) are available as optional extras.
- Install an in-line fuel filter between the tank and carburetor to prevent foreign matter in the tank from entering the carburetor.
- Clean these filters periodically.
- If these precautions are neglected, restriction of fuel flow may cause the engine to cut out, or the fuel/air mixture to become too lean causing the engine to overheat.

- Do not close the needlevalve and mixture control valve too far as this will cause a lean setting and over heating of the engine. Always adjust the needlevalve slightly on the rich side of peak rpm.
- Do not leave unused fuel in the engine at the conclusion of a day's flying. Accepted practice is to cut off the fuel supply while the engine is still running at full throttle, then expel as much fuel residue as possible by turning the engine over 5-10 seconds with the electric starter.
- When the engine is not to be used for some months (for example, as between flying seasons), a worthwhile precaution is to remove it from the airframe and, after washing off the exterior with alcohol (not gasoline nor kerosene), remove carefully the carburetor, glow plug and all silicone tubing and put them safely aside. Then, immerse the engine in a container of alcohol. Rotate the crankshaft while the engine is immersed. If foreign matter is visible in the alcohol, rinse the engine again in clean alcohol. Finally, shake off and dry the alcohol, and inject some after-run oil in the glowplug hole and rotate the crankshaft several times by hand. Reinstall the carburetor and glowplug on the engine and keep it in a dry place after putting in a vinyl bag.

No.	Code No.	Description
1	27404010	Cylinder Head
2	27414010	Head Gasket
3	27403000	Cylinder & Piston Assembly
4	27406000	Piston Pin
5	27917000	Piston Pin Retainer (2pcs.)
6	27405000	Connecting Rod
7	27482020	Carburetor Complete (Type 61A-BE)
8	45910100	Lock Nut Set
9	27408010	Drive Hub
10	29320000	Thrust Washer
11	27731000	Crankshaft Ball Bearing (F)
12	27401000	Crankcase
13	29030001	Crankshaft Ball Bearing (R)
14	27402000	Crankshaft
15	27414020	Cover Gasket
16	27407000	Cover Plate
	71668100	Glow Plug BE-3
	72200080	Needle Valve Extension Cable Set
	27425000	E-4040 Silencer Assembly
	29122540	"O" Ring
	27425300	Assembly Screw
	22681957	Pressure Nipple (No.7)
	26625210	Silencer Retaining Screw (C-M4x40 2pcs.)

The specifications are subject to alteration for improvement without notice.

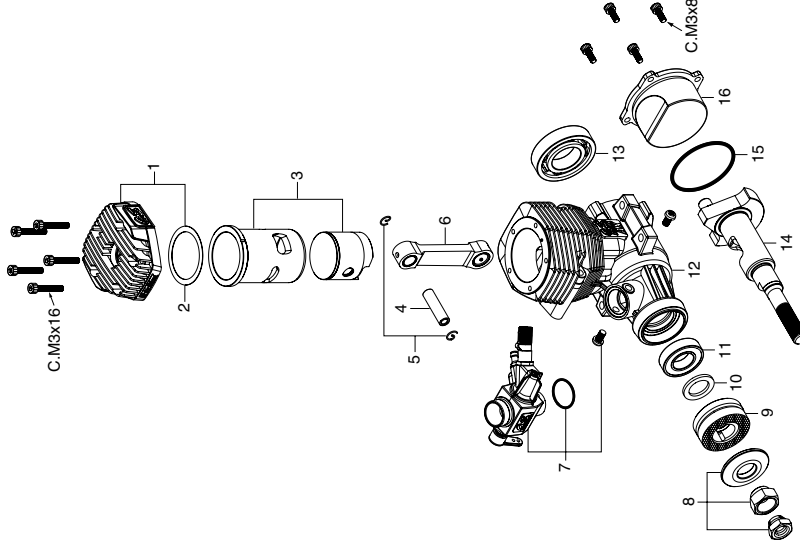

CAP SCREW SETS (10pcs./sets)

Code No.	Size	Pcs. used in an engine
79871110	M3x8	Cover Plate Retaining Screw (4pcs.)
79871160	M3x16	Cylinder Head Retaining Screw (5pcs.)

*Type of screw
C...Cap Screw

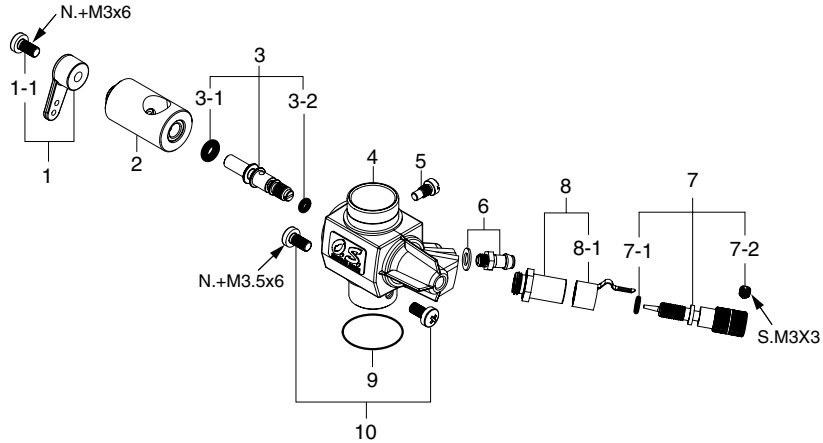

* Type of screw
 C...Cap Screw M...Oval Fillister-Head Screw
 F...Flat Head Screw N...Round Head Screw S...Set Screw

No.	Code No.	Description
1	22081408	Throttle Lever Assembly
1-1	22081313	Assembly Screw
2	25781200	Carburetor Rotor
3	25781600	Mixture Control Valve Assembly
3-1	46066319	"O" Ring (L) (2pcs.)
3-2	22781800	"O" Ring (S) (2pcs.)
4	27482120	Carburetor Body
5	45581820	Roter Guide Screw
6	22681953	Fuel Inlet (No.1)
7	25781970	Needle Assembly
7-1	24981837	"O" Ring (2pcs.)
7-2	26381501	Set Screw
8	27381940	Needle-valve Holder Assembly
8-1	26711305	Ratchet Spring
9	46215000	Carburetor Rubber Gasket
10	25081700	Carburetor Retaining Screw

Specifications are subject to alteration for improvement without notice.

■ **O.S.GLOW PLUG**
BE-3
(71668100)



■ **O.S. Bio-Ethanol glow fuel**
BE-1(4L)
(79710000)

■ **RADIAL MOTOR MOUNT**
(71905200)

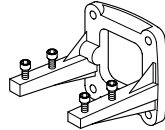

■ **PROPELLER LOCKNUT SET (For Spinner)**
5/16-M4
(45910200)

■ **SILENCER EXTENSION ADAPTORS**

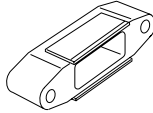

	Width	Screw hole pitch
(26625340)	14.5mm	42.0mm
(26625500)	35.0mm	42.0mm

■ **NON-BUBBLE WEIGHT**
(71531000)



■ **NON-BUBBLE WEIGHT**
S (71531010)



■ **SUPER FILTER (L)** (72403050)



■ **BLIND NUT**
M3 (79870030)
M4 (79870040)



■ **LOCK WASHER (10sets)**
M3 (55500002)
M4 (55500003)

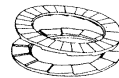

■ **CAP SCREW SETS (10pcs./sets)**

- M3x8 (79871110)
- M3x16 (79871160)



■ **LONG SOCKET WRENCH WITH PLUG GRIP**

(71521000)

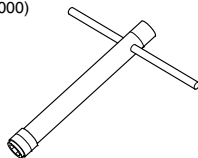

The specifications are subject to alteration for improvement without notice.

SPECIFICATIONS

■ Displacement	12.29 cc / 0.75 cu.in.
■ Bore	25.8 mm / 1.016 in.
■ Stroke	23.5 mm / 0.925 in.
■ Practical R.P.M.	2,300-10,000 r.p.m.
■ Power output	1.2 ps / 1.22 hp / 10,000r.p.m.
■ Weight	583 g / 20.56 oz.

	E-4040 Silencer
	178 g / 6.28 oz.

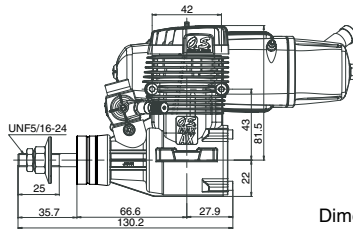
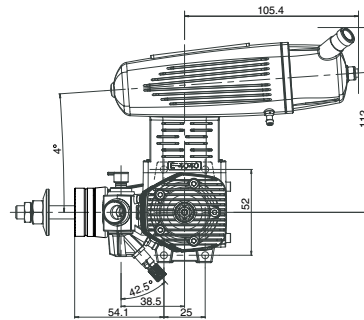
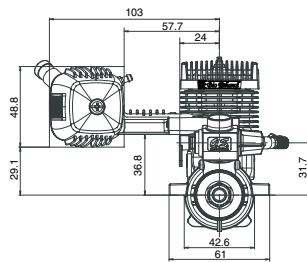

Dimensions(mm)

